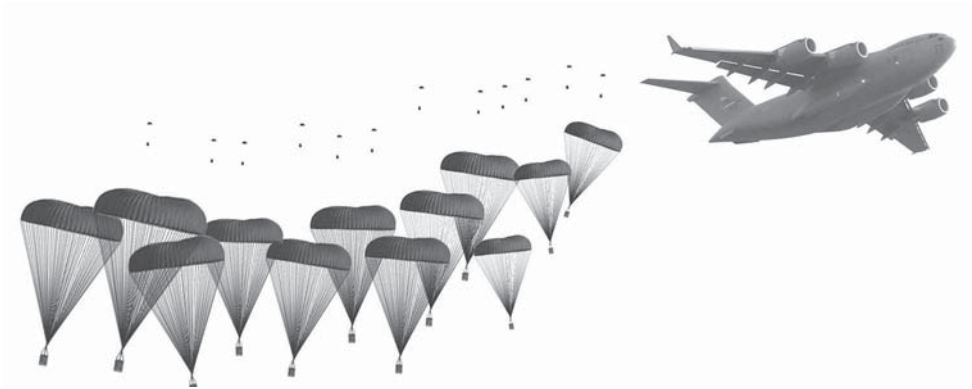


FM 4-20.103 (FM 10-500-3)  
MCRP 4-11.3C  
TO 13C7-1-11



## AIRDROP OF SUPPLIES AND EQUIPMENT: RIGGING CONTAINERS



September 2005

DISTRIBUTION RESTRICTION: Approved for public release; distribution is unlimited.

HEADQUARTERS  
DEPARTMENT OF THE ARMY  
UNITED STATES MARINE CORPS  
DEPARTMENT OF THE AIR FORCE

**This publication is available at  
Army Knowledge Online ([www.us.army.mil](http://www.us.army.mil)) and  
General Dennis J. Reimer Training and Doctrine  
Digital Library at (<http://www.train.army.mil>).**

Field Manual  
NO 4-20.103  
Marine Corps Reference Publication  
NO 4-11.3C  
Technical Order  
NO 13C7-1-11

HEADQUARTERS  
DEPARTMENT OF THE ARMY  
UNITED STATES MARINE CORPS  
DEPARTMENT OF THE AIR FORCE  
Washington, DC, 2 September 2005

# **Airdrop of Supplies and Equipment: Rigging Containers**

## **TABLE OF CONTENTS**

	<b>Page</b>
<b>Preface</b> .....	<b>viii</b>
<b>PART ONE GENERAL INFORMATION</b>	
<b>Chapter 1 General Rigging Information For Container Loads</b>	
Description of Container Loads .....	1-1
Types of Airdrop .....	1-2
Commonly Used Items .....	1-3
Parachute Requirements .....	1-4
Data Tag for Rigged Loads .....	1-4
Computation of Minimum Weight for Container Loads .....	1-5
Special Considerations .....	1-6
Safety Precautions .....	1-7
Rigging Precautions .....	1-7
Loads Dropped in Frigid Climates .....	1-8
Final Inspection .....	1-8
Release Gate .....	1-8
Release Gate Load Spreader .....	1-9
Knots Used .....	1-10
Securing Straps and Webbing .....	1-11
<b>Chapter 2 Aircraft Information</b>	
Army Aircraft .....	2-1
Air Force Aircraft .....	2-2
Marine Corps Aircraft .....	2-2
Centerline Vertical Restraint System .....	2-3
Non-CVRS Load .....	2-4
Inboard Logistics Rail .....	2-4

**DISTRIBUTION RESTRICTION: Approved for public release; distribution is unlimited.**

**\* This publication supersedes FM 10-500-3, 8 December 1992**

**MARINE CORPS PCN: 14400013000**

	Page
<b>PART TWO</b>	<b>RIGGING A-7A CONTAINER LOADS</b>
<b>Chapter 3</b>	<b>General Information and Procedures</b>
	A-7A Airdrop Cargo Sling Assembly ..... 3-1
	Weight Limits ..... 3-2
	A-7A Container Loads ..... 3-2
	Parachutes for A-7A Loads ..... 3-2
	Modifying the T-10 Parachute ..... 3-17
<b>Chapter 4</b>	<b>Rigging Typical A-7A Containers</b>
<b>Section I</b>	<b>Low-Velocity Airdrop from Paratroop Door</b>
	Description of Load ..... 4-1
	Positioning Straps ..... 4-1
	Positioning Load and Securing Straps ..... 4-2
	Installing Parachute ..... 4-5
	Marking Rigged Load ..... 4-5
	Equipment Required ..... 4-5
<b>Section II</b>	<b>Low-Velocity Airdrop from Ramp</b>
	Description of Load ..... 4-7
	Preparing Skid Board ..... 4-7
	Placing Honeycomb and Positioning Straps ..... 4-8
	Positioning Load and Securing Straps ..... 4-8
	Securing Skid Board ..... 4-8
	Installing Parachute ..... 4-10
	Marking Rigged Load ..... 4-11
	Equipment Required ..... 4-11
<b>Section III</b>	<b>High-Velocity Airdrop</b>
	Description of Load ..... 4-12
	Preparing Drop Items ..... 4-12
	Preparing Skid Board ..... 4-12
	Placing Honeycomb ..... 4-13
	Securing Straps ..... 4-14
	Securing Skid Board ..... 4-14
	Installing Parachute ..... 4-14
	Marking Rigged Load ..... 4-14
	Equipment Required ..... 4-14

	Page
<b>PART THREE RIGGING A-21 CONTAINER LOADS</b>	
<b>Chapter 5 General Information and Procedures</b>	
A-21 Cargo Bag Assembly .....	5-1
Capabilities of A-21 Cargo Bag .....	5-2
Parachutes Used for A-21 Cargo Bag .....	5-2
Installing Parachute on A-21 Cargo Bags .....	5-2
<b>Chapter 6 Rigging Typical A-21 Loads</b>	
<b>Section I Low-Velocity Airdrop From Paratroop Door</b>	
Description of Load .....	6-1
Preparing Drop Items .....	6-1
Positioning Container and Load .....	6-1
Rigging Container .....	6-3
Installing Parachute .....	6-5
Marking Rigged Load .....	6-5
Equipment Required .....	6-5
<b>Section II Low-Velocity Airdrop From Ramp</b>	
Description of Load .....	6-6
Preparing Drop Items .....	6-6
Preparing Skid Board .....	6-6
Positioning Container and Load .....	6-6
Rigging Container .....	6-6
Securing Skid Board .....	6-8
Installing Parachute .....	6-9
Marking Rigged Load .....	6-9
Equipment Required .....	6-9
<b>Section III High-Velocity Airdrop</b>	
Description of Load .....	6-10
Prepaing Drop Items .....	6-10
Preparing Skid Board .....	6-11
Positioning Honeycomb .....	6-11
Positioning Container and Load .....	6-12
Rigging Container .....	6-12
Securing Skid Board .....	6-12
Installing Parachute .....	6-12
Marking Rigged Load .....	6-12
Equipment Required .....	6-12

		<b>Page</b>
<b>Chapter 7</b>	<b>Rigging Ground Laser Location Designator in A-21 Container Rigged for Low-Velocity Airdrop</b>	
	Description of Load .....	7-1
	Preparing Skid Boards .....	7-1
	Placing Honeycomb and Top Skid Board .....	7-1
	Rigging GLLD .....	7-1
	Installing Parachute .....	7-1
	Marking Rigged Load .....	7-1
	Equipment Required .....	7-1
<b>PART FOUR</b>	<b>RIGGING A-22 CONTAINER LOADS</b>	
<b>Chapter 8</b>	<b>General Information and Procedures</b>	
	A-22 Cargo Bag Assembly .....	8-1
	A-22 Skid Board .....	8-2
	A-22 Container Limitations .....	8-2
	Double A-22 Cargo Bag .....	8-2
	Stretch A-22 Cargo Bag .....	8-3
	Assembly Line Rigging .....	8-3
	Inspecting Load .....	8-3
	Parachutes Used .....	8-3
	Installing Parachutes .....	8-4
<b>Chapter 9</b>	<b>Rigging Typical A-22 Loads</b>	
<b>Section I</b>	<b>Rigging A-22 Loads for Low-Velocity Airdrop</b>	
	Description of Load .....	9-1
	Preparing Drop Items .....	9-1
	Preparing Skid Board .....	9-1
	Positioning Honeycomb .....	9-3
	Positioning A-22 Cargo Bag Sling, Cover, and Load .....	9-4
	Securing A-22 Cargo Bag Cover .....	9-5
	Securing A-22 Cargo Bag Sling .....	9-6
	Securing Skid Board to A-22 Cargo Bag .....	9-7
	Attaching Suspension Webs .....	9-8
	Installing Parachute .....	9-9
	Marking Rigged Load .....	9-9
	Equipment Required .....	9-10
<b>Section II</b>	<b>Rigging A-22 Loads for High-Velocity Airdrop</b>	
	Description of Load .....	9-10
	Preparing Items and Skid Board .....	9-10
	Positioning Honeycomb .....	9-11
	Rigging Container .....	9-12
	Installing Parachute .....	9-12

		<b>Page</b>
	Marking Rigged Load .....	9-14
	Equipment Required .....	9-15
<b>Section III</b>	<b>Rigging Double A-22 Cargo Bag Loads for Low-Velocity Airdrop</b>	
	Description of Load .....	9-15
	Preparing Skid Board .....	9-16
	Preparing Skid Board Ties and Positioning Honeycomb .....	9-17
	Positioning A-22 Sling Assemblies .....	9-18
	Positioning Covers .....	9-20
	Positioning Load and Closing Bag Covers .....	9-21
	Securing Tie-Down Straps .....	9-22
	Securing Lateral Straps .....	9-23
	Securing Skid Board Ties .....	9-24
	Installing Suspension Slings .....	9-25
	Installing Parachute .....	9-26
	Marking Rigged Load .....	9-27
	Equipment Required .....	9-28
<b>Section IV</b>	<b>Rigging Stretch A-22 Cargo Bag Loads for Low-Velocity Airdrop</b>	
	Description of Load .....	9-28
	Preparing Skid Board .....	9-29
	Preparing Skid Board Ties and Positioning Honeycomb .....	9-29
	Positioning A-22 Sling Assemblies .....	9-30
	Positioning Covers .....	9-32
	Positioning Load and Closing Bag Covers .....	9-33
	Securing Tie-Down Straps .....	9-34
	Securing Lateral Straps .....	9-35
	Securing Skid Board Ties .....	9-36
	Installing Suspension Slings .....	9-37
	Installing Parachute .....	9-38
	Marking Rigged Load .....	9-39
	Equipment Required .....	9-39
<b>Chapter 10</b>	<b>Rigging Petroleum Products</b>	
	Description of Load .....	10-1
	Preparing Skid Board and Positioning Honeycomb .....	10-1
	Positioning Container .....	10-1
	Positioning Load .....	10-1
	Securing Container and Installing Parachute .....	10-2
	Equipment Required .....	10-3

**Chapter 11 Rigging Specific Double A-22 Loads**

Section I	Rigging Snowmobile	
	Description of Load .....	11-1
	Preparing Skid Board .....	11-1
	Positioning Container .....	11-1
	Positioning Honeycomb .....	11-1
	Preparing Snowmobile .....	11-4
	Positioning Load .....	11-6
	Completing Rigged Load .....	11-8
	Marking Rigged Load .....	11-8
	Equipment Required .....	11-8
Section II	Rigging Ahkio Sleds	
	Description of Load .....	11-11
	Prepaing Skid Board and Positioning Honeycomb and Container .....	11-11
	Positioning Load .....	11-11
	Completing Rigged Load .....	11-11
	Marking Rigged Load .....	11-13
	Equipment Required .....	11-13

**PART FIVE RIGGING LOW-COST AERIAL DELIVERY SYSTEM**

**Chapter 12 General Information and Procedures**

LCADS Components .....	12-1
LCADS Skid Board .....	12-1
LCADS Container Limitations .....	12-2
Inspecting Load .....	12-2
Parachute Used .....	12-2

**Chapter 13 Rigging Typical Low-Cost Aerial Delivery System Loads**

Section I	Rigging LCADS for Low-Velocity Airdrop	
	System Description .....	13-1
	Preparing Items and Skid Board .....	13-1
	Perparing and Placing Honeycomb .....	13-1
	Positioning Sling Assembly .....	13-2
	Positioning Load and Securing Sling Assembly .....	13-3
	Securing Sling Assembly to Skid Board .....	13-5
	Installing Parachute .....	13-6
	Marking Rigged Load .....	13-7
	Equipment Required .....	13-7
Section II	Rigging LCADS for High-Velocity Airdrop	
	System Description .....	13-9
	Preparing Items and Skid Board .....	13-9



Positioning Honeycomb .....	13-9
Positioning Sling Assembly .....	13-9
Positioning Load and Securing Sling Assembly .....	13-10
Securing Sling Assembly to Skid Board .....	13-10
Installing Parachute .....	13-11
Marking Rigged Load .....	13-14
Equipment Required .....	13-14

**PART SIX RIGGING SPECIALIZED LOADS AND EQUIPMENT**

**Chapter 14 Fabricating Air Force Airdrop Equipment**

Section I Air Force Unilateral Training

Description of Load .....	14-1
Preparing Sandbag .....	14-1
Fabricating SATB .....	14-2
Attaching Pendulum Line .....	14-4
Packing and Installing Pilot Parachute .....	14-6
Attaching Marker Light .....	14-7
Using Extraction Parachute Deployment Bag .....	14-7
Equipment Required .....	14-8

Section II Fabrication of C-130 CDS Pulley Strap

Description of C-130 CDS Pulley Strap .....	14-8
Preparing C-130 CDS Pulley Strap .....	14-8

Section III CDS Kit

Description and Use of CDS Kit .....	14-9
Equipment Required .....	14-9

<b>Glossary .....</b>	<b>Glossary-1</b>
<b>Bibliography .....</b>	<b>Bibliography-1</b>

## Preface

### SCOPE

This manual provides the latest approved doctrine for rigging airdrop containers. It is written for use by a parachute rigger or jumpmaster. It consists of six parts.

- a. Part one contains general information for container loads and aircraft.
- b. Part two contains procedures for rigging A-7A container loads.
- c. Part three contains procedures for rigging A-21 container loads.
- d. Part four contains procedures for rigging A-22 container loads.
- e. Part five contains procedures for rigging low-cost aerial delivery systems.
- f. Part six contains procedures for rigging specialized loads and equipment.

### NOTICE OF EXCEPTION

When an item of airdrop equipment is replaced or a rigging procedure is changed, it will be impossible to change all manuals in the field at one time. Therefore, Field Manual (FM) 4-20.103/Marine Corps Reference Publication (MCRP) 4-11.3C/Technical Order (TO) 13C7-1-11 will be changed, when necessary and will take precedence over the procedures in an individual rigging manual. There may be times, however, when the procedures in an individual rigging manual must be followed even though they are different from those in this manual. When this occurs, a notice of exception will be printed at the beginning of each paragraph where the exception is authorized. The notice of exception will look like the following:

#### NOTICE OF EXCEPTION

The procedures in this paragraph are different from those in FM 4-20.103/MCRP 4-11.3C/TO 13C7-1-11. An exception to FM 4-20.103/MCRP 4-11.3C/TO 13C7-1-11 is granted. The procedures in this paragraph must be followed.

### REFERENCE INFORMATION

To avoid repeating certain information and procedures, it is often necessary to reference other FMs and technical manuals (TM). For example, this manual often references FM 4-20.102/Naval Sea Command (NAVSEA) SS400-AB-MMO-010/TO 13C7-1-5. This may seem to be contradictory in that this manual, FM 4-20.103/MCRP 4-11.3C/TO 13C7-1-11, deals with rigging container loads and FM 4-20.102/NAVSEA SS400-AB-MMO-010/TO 13C7-1-5 deals with rigging platform loads. However, FM 4-20.102/NAVSEA SS400-AB-MMO-010/TO 13C7-1-5 also provides general information and general procedures. Where information is the same or only minor differences exist, it is permissible to state that the information is provided in FM 4-20.102/NAVSEA SS400-AB-MMO-010/TO 13C7-1-5. Where procedures are the same or only minor differences exist it is permissible to state that the procedure is done according to or by adapting the procedures in FM 4-20.102/NAVSEA SS400-AB-MMO-010/TO 13C7-1-5.

## USER INFORMATION

This publication applies to the Active Army, the Army National Guard (ARNG)/Army National Guard of the United States (ARNGUS), and the United States Army Reserve (USAR).

The proponent of this publication is the United States Army Training and Doctrine Command (TRADOC). You are encouraged to report any errors or omissions and to suggest ways of making this a better manual.

Army personnel, send your comments on DA Form 2028 directly to:

Director  
Aerial Delivery and Field Services Department  
USA Quartermaster Center and School  
710 Adams Avenue  
Fort Lee, Virginia 23801-1502

Air Force personnel, send your reports on AFTO Form 22 through your respective command Weapons and Tactics to:

Headquarters  
Air Mobility Command (AMC/A39T)  
402 Scott Drive, Unit 3AI  
Scott AFB, Illinois 62225-5302

Air Force personnel in Special Operations Command, send your reports on AFTO Form 22. HQ AMC/A39T will consolidate and forward changes to:

Director  
Aerial Delivery and Field Services Department  
USA Quartermaster Center and School  
710 Adams Avenue  
Fort Lee, Virginia 23801-1502

Also send an information copy of AFTO Form 22 to:

WR-ALC/LEET  
295 Byron Street  
Robins AFB, Georgia 31098-1611

Marine Corps personnel, send your comments to:

Marine Corps Combat Development Command  
Doctrine Division (C398)  
3300 Russell Road, Suite 318A  
Quantico, Virginia 22134-5010

**This page intentionally left blank.**

---

## PART ONE

# GENERAL INFORMATION

## Chapter 1

### General Rigging Information For Container Loads

#### DESCRIPTION OF CONTAINER LOADS

1-1. Container loads are loads that are rigged for airdrop in airdrop containers such as the A-7A airdrop cargo sling assembly, the A-21 cargo bag assembly, and the A-22 cargo bag assembly. These containers are packed with supplies, disassembled equipment, or small items of ready-to-use equipment prepared for airdrop. Loads may be required to be cushioned with energy dissipating material (honeycomb), felt, or cellulose wadding depending on the load requirements and the method of airdrop. The number and types of parachutes required to stabilize the load and slow its descent depend on the type of container used, the weight of the load, and the type of airdrop.

a. **A-7A Airdrop Cargo Sling Assembly.** The A-7A airdrop cargo sling assembly consists of four identical sling straps. The length of each strap is 188 inches. Each sling strap is fitted with a friction adapter and a floating D-ring. Loads weighing up to 500 pounds may be airdropped with an A-7A airdrop cargo sling assembly. Each A-7A cargo sling strap weighs 1 1/2 pounds. Part Two of this manual covers rigging the A-7A container for airdrop.

b. **A-21 Cargo Bag Assembly.** The A-21 cargo bag assembly is an adjustable container. It consists of a sling assembly with scuff pad, fixed quick-release strap and assembly, two O-ring straps, three quick-release straps, and a 97- by 115-inch canvas cover. The A-21 cargo assembly has a 500-pound load capacity. Part Three of this manual covers rigging an A-21 container for airdrop.

c. **A-22 Cargo Bag Assembly.** The A-22 cargo bag assembly is an adjustable cotton duck cloth/nylon and nylon webbing container. It consists of a sling assembly, a cover, and four suspension webs. The container weight is about 41 pounds. The load may be rigged with or without a cover. The weight capacity for the container is 501 to 2,200 pounds without the weight of the parachute. The height will vary, but will not exceed 83 inches with parachute unless specific rigging procedure authorizes it. Containers rigged for C-17 airdrop are restricted to 101 inches. Part Four of this manual covers rigging the A-22 container for airdrop.

d. **Stretch A-22 Cargo Bag.** The stretch A-22 cargo bag consists of two A-22 cargo bag assemblies. The covers may or may not be used. Only six of the suspension webs are used. Nylon and cotton sling assemblies must not be mixed. The weight capacity of the load is 675 to 2,200 pounds without the weight of the parachute. Part Four of this manual covers rigging the stretch A-22 container for airdrop.

e. **Double A-22 Cargo Bag.** The double A-22 cargo bag consists of two A-22 cargo bag assemblies. The covers may or may not be used. Only six of the suspension webs are used. Nylon and cotton sling assemblies must not be mixed. The weight capacity of the load is 900 to 2,200 pounds without the weight of the parachute. Part Four of this manual covers rigging the double A-22 container for airdrop.

f. **Low-Cost Aerial Delivery System (LCADS).** LCADS is a modified, lightweight A-22 container with no scuff pad, cover, or friction adapters on the lateral bands. It is rigged like the A-22 container, but is used for high-volume delivery of items where airdrop equipment is not recoverable. The weight capacity of the load is 501 to 2,200 pounds without the weight of the parachute. Part Five of this manual covers rigging the LCADS for airdrop.

## TYPES OF AIRDROP

1-2. The three types of airdrop by which container loads can be delivered are low-velocity airdrop, high-velocity airdrop, and free drop. These are described below.

a. **Low-Velocity Airdrop.** Low-velocity airdrop is the delivery of supplies and equipment from an aircraft in flight using cargo parachutes. The items are usually rigged with honeycomb under them. The cargo parachutes are attached to the top of the load. The parachutes slow the descent of the load and ensure minimum shock when the load hits the ground.

b. **High-Velocity Airdrop.** High-velocity airdrop is the delivery of supplies and equipment from an aircraft in flight using a stabilizing parachute. The items are rigged with honeycomb under them. The stabilizing parachute is attached to the top of the load to maintain it in an upright position.

c. **Free Drop.** Free drop is the delivery of certain nonfragile items of supply from an aircraft in flight without the use of a parachute. No specific instructions are given in this manual for this type of airdrop.

## COMMONLY USED ITEMS

1-3. Items commonly used for rigging container loads are described below. An equipment required table is included for each load in this manual as a part of the section describing that load. This table lists the items and quantity of each item needed to prepare and rig the load covered in that section. Standard airdrop hardware straps, and canvas items are described in FM 4-20.102/NAVSEA SS400-AB-MMO-010/TO 13C7-1-5. Canvas, metal, webbing and wood items are inspected according to TM 10-1670-298-20&P. Strength rating for the items in this section and for other airdrop items are listed in FM 4-20.116/TO 13C7-1-13. Some textile, wood, and miscellaneous items are described below. The proper use of these items will be covered in this manual or in other manuals of the FM 4-20/TO 13C7 (FM 10-500) series.

a. **Textile Items.** Textile items which may be used when a container load is being rigged are described below.

**NOTE:** Lengths will vary. Lengths specified are only typical and may be changed.

(1) Type III nylon cord is used to make safety ties and to hold items in place. It has a tensile strength of 550 pounds.

**NOTE:** When 1/2-inch (or 5/8-inch) tubular nylon webbing is not available for the skid board tie, type IV (coreless) braided nylon cord can be used. When the type IV (coreless) braided nylon cord is not available, double length of type III nylon cord can be used.

(2) One-half-inch (or 5/8-inch) tubular nylon webbing is used as a primary skid board tie. It is also used to secure items during a drop. It has a tensile strength of 1,000 pounds.

(3) Type I, 1/4-inch cotton webbing is used to make many of the needed safety ties. It has a tensile strength of 80 pounds.

(4) Ticket numbers 8/4 and 8/7 cotton thread are used to make various ties.

b. **Wood Items.** Wood items used on container loads, with the exception of the A-22 skid board, are made locally using details found in the rigging manual for the particular load. The 48- by 48-inch skid board for the A-22 cargo bag may be ordered precut or prepared locally. When the skid board is prepared locally, AC grade plywood must be used.

c. **Miscellaneous Items.** Miscellaneous items which may be used when a container load is being rigged are described below.

(1) Two-inch masking tape is used to prevent honeycomb from being cut by the type III nylon cord and to hold padding in place.

(2) Cellulose wadding and felt sheets may be used to pad fragile items to prevent sharp edges from cutting and to protect slings during deployment.

(3) Honeycomb is used to absorb the landing shock. Honeycomb is also used to fill empty spaces and to level and pad the load. The number of layers used depends on the item being airdropped and the method of airdrop. Honeycomb is issued in 3- by 36- by 96-inch sheets.

(4) Steel strapping may be used for rigging airdrop items. The standard strapping used is 1/50 inch thick and 5/8 inch wide with a breaking strength of 1,000 pounds. It can be used to bind items together or form containers on A-7A and A-21 loads. When strapping is used to form containers, it will be doubled and the maximum weight of the load will not exceed 250 pounds without parachute weight. When strapping is used on A-22 loads, it will not be bound around the skid board unless specific rigging procedures authorize it.

## PARACHUTE REQUIREMENTS

1-4. The parachute requirements for low-velocity and high-velocity airdrop are as described below.

a. **Low-Velocity Airdrop.** The 68-inch pilot, T-10 modified cargo, and G-14 cargo parachutes are used singularly with A-7A cargo sling loads and A-21 cargo bag loads rigged for low-velocity airdrop. Three 68-inch pilot parachutes may be used only on A-7A sling loads. The G-14 in clusters of two or three parachutes or a G-12 cargo parachute is used on A-22 cargo bag loads. The minimum required weight and the maximum allowable weight for cargo parachutes used on loads rigged for low-velocity airdrop are listed in Table 1-1.

b. **High-Velocity Airdrop.** A 68-inch pilot parachute is the primary parachute used for a 75- to 150-pound load without parachute weight being prepared for high-velocity airdrop. For loads between 150 to 500 pounds, use the 12-foot high-velocity parachute. When the 12-foot high velocity parachute is not available, a 15-foot cargo extraction parachute packed specifically for use as a high-velocity parachute may be used. For loads over 500 pounds, the 26-foot high-velocity cargo parachute is the primary parachute and should be used whenever possible. See Table 1-1 for weight ranges. If the 26-foot high-velocity parachute is not available, a 22-foot cargo extraction parachute packed specifically for use as a high-velocity parachute may be used. Special procedures for the 15- and 22-foot extraction parachute consist of attaching the static lines and replacing the extraction line with a 20-foot cargo sling (see TM 10-1670-278-23&P/TO 13C5-26-2/NAVAIR 13-1-27 for the 15-foot extraction parachute and TM 10-1670-279-23&P/TO 13C5-27-2/NAVAIR 13-1-28 for the 22-foot extraction parachute).

## DATA TAG FOR RIGGED LOADS

1-5. A data tag is prepared and secured to each container load so that it can be easily seen. Entries on the tag are used for inspection purposes and to help the loadmaster determine where to place the loads in the aircraft. Use a ballpoint pen or other waterproof marker to record the following information on the tag:



- a. Total rigged weight.
- b. Height, including parachute.
- c. Width.
- d. Overall length.
- e. Type of parachute/breakaway or nonbreakaway.

**Table 1-1. Parachute Requirements**

Parachute	Suspended Weight (Pounds)	
	Minimum	Maximum
<b>Low-Velocity</b>		
One 68-inch pilot	30	50
Three 68-inch pilot	51	200
One T-10 modified cargo	90	500
One G-14 cargo	200	500
* Two G-14 cargo	501	1,000
* Three G-14 cargo	1,001	1,500
* One G-12E cargo	501	2,200
<b>High-Velocity</b>		
** One 68-inch pilot	75	150
Three 68-inch pilot	151	500
** One 12-foot high velocity cargo	151	500
One 15-foot cargo extraction	151	500
** One 26-foot high velocity cargo	501	2,200
One 22-foot cargo extraction	501	2,200
* On an A-22 load, a G-14 cargo parachute should be used only when a G-12 cargo parachute is not available.		
** Primary parachute.		
NOTE: Loads with three G-14 cargo parachutes must be dropped one at a time.		

**COMPUTATION OF MINIMUM WEIGHT FOR CONTAINER LOADS**

1-6. The following information can be used to determine the minimum weight required for a container load.

- a. Container loads may be dropped from the paratroop doors or the ramp.
  - (1) **Paratroop Door Loads.** Containers dropped from the paratroop doors require a minimum weight of 11 pounds per square foot.
  - (2) **Ramp Loads.** Containers dropped from the ramp require a minimum weight of 28 pounds per square foot.

b. To compute the minimum weight required for a container load, measure the length, width, and height (without parachute) of each container. Multiply the two largest dimensions (in inches). Divide the answer by 144. Multiply that answer by 28 (or 11 for paratroop door loads). The answer is the minimum allowable weight for that load. See the example in Table 1-2.

**Table 1-2. Example of How to Determine Minimum Allowable Weight**

<b>Example:</b>	
Height (without parachute)	27 inches
Length	44 inches
Width	21 inches
44 inches x 27 inches = 1,188 square inches	
1,188 ÷ 144 = 8.25 square feet	
<b>RAMP</b>	
8.25 x 28 = 231 pounds	
The minimum allowable weight for this container is 231 pounds, without parachute, for ramp operations.	
<b>DOOR</b>	
8.25 x 11 = 90.75 pounds	
The minimum allowable weight for this container is 90.75 pounds, without parachute for door operations.	

## SPECIAL CONSIDERATIONS

1-7. Special considerations for this manual are described below.

### CAUTION

Only ammunition listed in FM 4-20.153/MCRP 4-11.3B/ TO 13C7-18-41/may be airdropped.

a. The loads covered in this manual may include hazardous materials as defined in AFMAN 24-204(I)/TM 38-250. If included, the hazardous material must be packaged, marked, and labeled as required by AFMAN 24-204(I)/ TM 38-250.

b. A copy of FM 4-20.103/TO 13C7-1-11 must be available to the joint airdrop inspectors during the before- and after-loading inspections.

## SAFETY PRECAUTIONS

### CAUTION

Package, mark, and label hazardous materials according to AFMAN 24-204(I)/TM 38-250.

1-8. Safety precautions must be closely followed when airdrop container loads are rigged. Failure to follow precautions could result in serious injury to the rigger or damage to the item or aircraft. Take the following safety precautions when rigging an item.

- a. Make sure that a lifting device has a rated lifting capacity that exceeds the weight of the item to be lifted.
- b. Be sure that items being lifted are secured to the lifting device.
- c. Do not work under equipment that is suspended above an airdrop container unless absolutely necessary.
- d. Cover all wet cell batteries in service with plastic or nonflammable material.
- e. Check the fuel tanks of engines to ensure that they are drained. Check fuel cans to make sure they are performance oriented packaging (POP) approved. When stowing fuel containers, use cellulose wadding or other suitable material to prevent metal-to-metal contact.

## RIGGING PRECAUTIONS

1-9. The following precautions must be taken when a container load is being rigged.

- a. **Assemblies.** When components of assemblies are being rigged, make sure that all items needed to operate the assembly are packed in the same airdrop container whenever possible. For example, a radio and its battery should be packed in the same container.
- b. **Items.** When items such as radio equipment are rigged, they should be individually wrapped. Padding or honeycomb should be placed under each item being prepared and inserted between items of the load to prevent contact. Cellulose wadding, felt or other suitable material must be used to avoid metal-to-metal or metal-to-wood contact.
- c. **Webbing.** All excess lengths of webbing must be folded and tied with type I, 1/4-inch cotton webbing. This reduces the danger of containers becoming snagged as they are ejected or released from the aircraft.
- d. **Hazardous Materials.** Hazardous materials must be packed and the rigged load labeled or marked according to Air Force Manual (AFMAN) 24-204(I)/TM 38-250. Gasoline cans and drums must be padded and rigged to prevent metal-to-metal contact.

## **LOADS DROPPED IN FRIGID CLIMATES**

1-10. When loads are dropped in frigid climates, special procedures or precautions may need to be followed. Some drop items may have been modified for use in frigid climates by the installation of extra equipment such as heaters. Special rigging procedures may be needed when a drop item has been modified.

## **FINAL INSPECTION**

1-11. After the data tag has been attached, the rigged load must be given a complete and final inspection by a qualified person. A-7A and A-21 loads may be inspected by either the jumpmaster or parachute rigger. All A-22 loads will be inspected by a parachute rigger. The load inspection must include the following.

- a. Check for serviceability of webbing, straps, and covers.
- b. Make sure load is rigged according to procedures outlined in this manual.
- c. Make sure the loads containing hazardous materials comply with AFMAN 24-204(I)/TM 38-250 and are labeled accordingly.
- d. Make sure the proper size parachute has been used and check its condition.
- e. Inspect the log record book.
- f. Make sure that the parachute is correctly connected to the load.

## **RELEASE GATE**

1-12. A release gate is installed in the aircraft to restrain the load during flight. It is also used to prevent premature exit of container loads from the aircraft. The gate is installed according to procedures in the technical order for the particular aircraft used. The components of the type XXVI nylon webbing release gate, with the exception of the webbing to be severed, are furnished by the US Air Force. The type XXVI nylon webbing is furnished by the user. See Table 1-3 for release gate requirements.

**Table 1-3. Release Gate Requirements**

Aircraft	Aircraft Rail System	Rigged Weight (Pounds)	Length of Type XXVI Nylon Webbing Required
C-130 (all models)	Non-CVRS*	501 - 13,000 13,001 - 25,000 25,001 - 40,000	One 20-foot Two 20-foot Three 20-foot
C-130 (all models)	CVRS*	501 - 13,000 13,001 - 25,000	One 15-foot per stick Two 15-foot per stick
C-17	Inboard Logistic Rail	501 - 18,800 18,001 - 37,600	20-foot single stick 40-foot double stick
<p>Note: For multiple deliveries, provide a release gate based on the weight of each group of containers to be airdropped at one time. * CVRS (centerline vertical restraint system)</p>			

**RELEASE GATE LOAD SPREADER**

1-13. Any time a container is rigged for container delivery system (CDS) and offered as the aft-most container but cannot firmly support the release gate to prevent excessive load shift, it must have a release gate load spreader. When the total weight of the container to be dropped from the C-17 aircraft exceeds 38,000 pounds, a release gate load spreader is needed for each aft-most container. Construct and secure it as given below.

- a. Nail two 3/4- by 24- by 48-inch pieces of plywood together using eight penny nails.
- b. Drill a 1/2-inch hole 2 inches from each corner.
- c. Place the spreader between the sling assembly and cover or load so the 48-inch side is parallel to the top and bottom of the container. Center the spreader on the release gate.
- d. Secure the corners of the spreader to the load with type III nylon cord routed through the 1/2-inch holes.

**NOTES:**

- 1. The user is responsible for offering a gate load spreader to prevent excessive load shift.
- 2. The number of joint airdrop inspection forms will be determined by the number of release gates used.

## KNOTS USED

1-14. Some knots used in rigging container loads are shown in Figure 1-1.

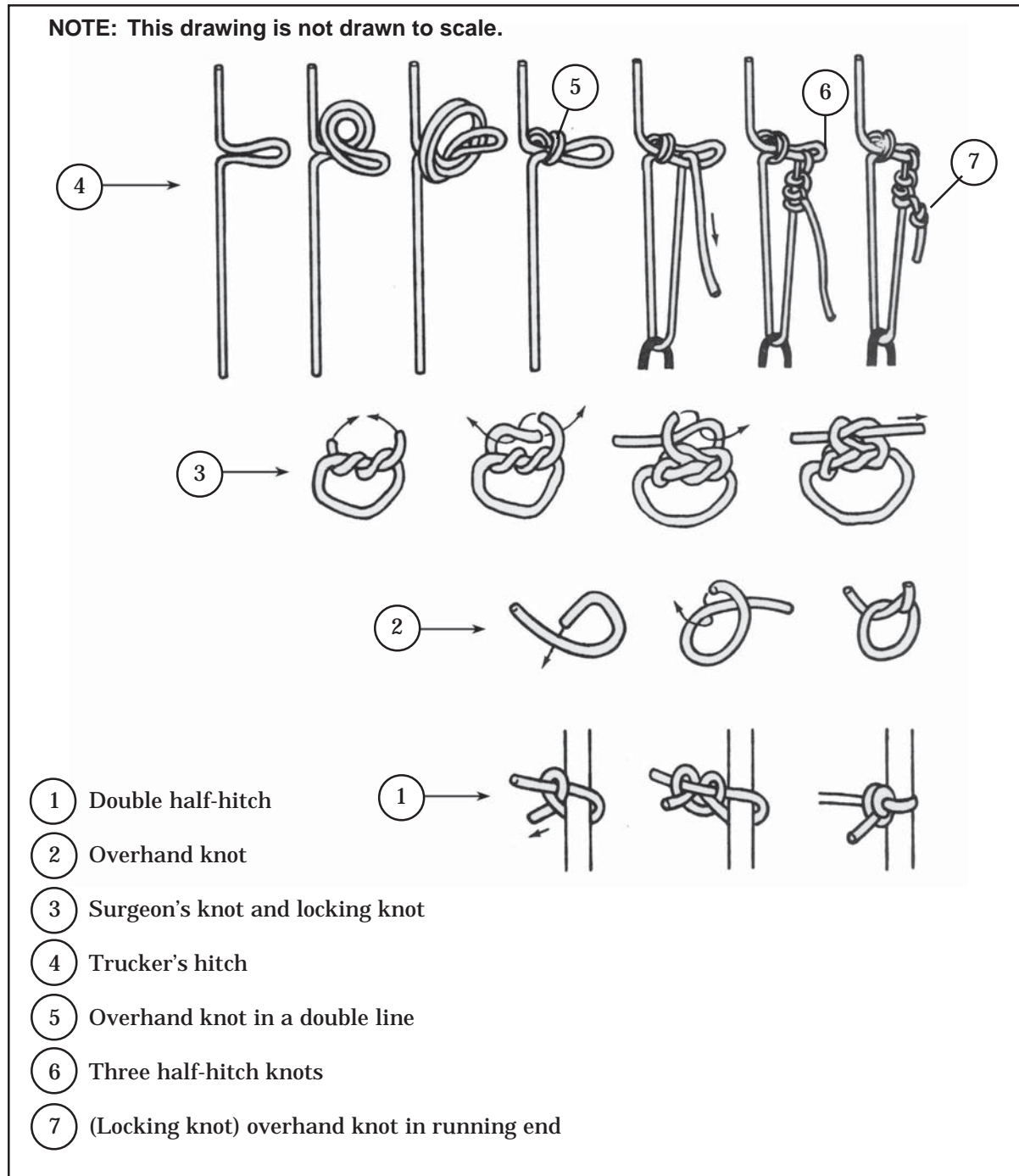


Figure 1-1. Knots Used

## SECURING STRAPS AND WEBBING

1-15. The straps and webbing used to rig loads must be properly fastened and secured.

### CAUTION

Instructions given in this paragraph must be followed exactly to ensure a malfunction-free drop.

a. **Fastening Strap With Friction Adapter.** All containers in this manual have friction adapters attached somewhere on the container. It is critical that the running ends of straps are routed properly. Figure 1-2 identifies the parts of the friction adapter. Figure 1-3 shows how to route the running end of the strap through the friction adapter.

b. **Securing Excess Strap.** Excess strap is folded and tied with type I, 1/4-inch cotton webbing. Figure 1-3 shows how to secure the excess strap.

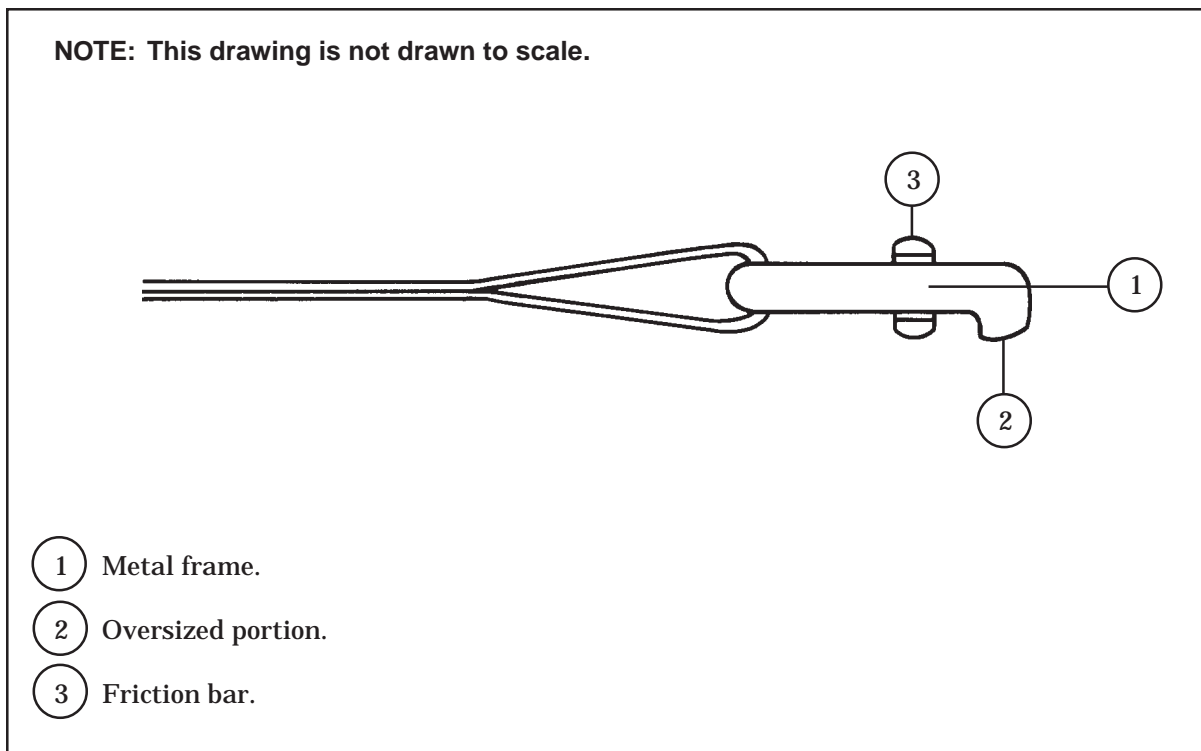
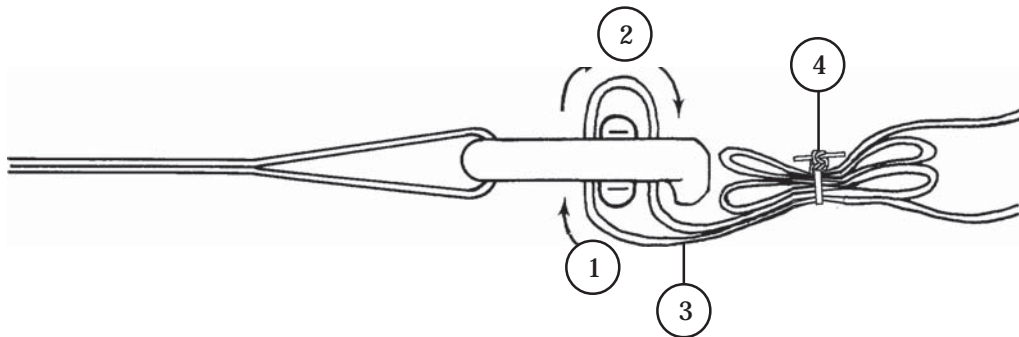


Figure 1-2. Friction Adapter

**NOTE: This drawing is not drawn to scale.**



- ① Using the running end of the webbing, route it up from the bottom between the friction bar and the stitch formation side of the metal frame.
- ② Route the running end down between the friction bar and the oversized portion of the metal frame.
- ③ Pull tension. The oversized portion of the metal frame should be pressing against the two layers of webbing.
- ④ S-fold the excess webbing. Secure it with one turn single, type I, 1/4-inch cotton webbing using a surgeon's knot and locking knot.

**Figure 1-3. Webbing Routed and Excess Secured**



## Chapter 2

# Aircraft Information

### ARMY AIRCRAFT

2-1. The following Army aircraft are used to airdrop loads.

a. **UH-60 (Blackhawk) Helicopter.** The UH-60 helicopter can carry supplies both internally (door loads) and externally (cargo hook loads). The allowable weight of the total cargo load is determined by responsible aviation personnel using weight limitation data provided in TM 11-1520-237-23-7. The weight and dimensional limits for both door loads and cargo hook loads are listed in Table 2-1.

b. **CH-47 (Chinook) Helicopter.** The CH-47 helicopter can deliver airdrop supplies over the ramp. The weight allowance of the total cargo load is determined by responsible aviation personnel using weight limitation data provided in TM 55-1520-240-23-10. Any standard A-7A cargo sling, A-21 cargo bag, or A-22 cargo bag load may be dropped from the cargo ramp. The maximum size of the load dropped from the external cargo hook is limited only by the maximum dimensions of the container.

**Table 2-1. Load Limitation for UH-60 Helicopter**

Door Load Data	UH-60
Weight (without parachutes)	
Maximum for A-7A or A-21	500 lb
Minimum for each container	*
Dimensions (including parachute)	
Length	48 in
Width	30 in
Height	42 in
* See Table 1-1 for the minimum weight requirements which are based on type of parachute.	

## AIR FORCE AIRCRAFT

2-2. The C-130 and C-17 aircraft can deliver container loads from the paratroop door or from the cargo ramp.

a. **Paratroop Door Loads.** The maximum weight limit for the paratroop door load is 500 pounds excluding the weight of the parachute. However, if the load weighs more than 350 pounds, three trained designated pushers must assist the jumpmaster in pushing the load from the aircraft. The dimensions including the parachute, must not exceed 48- by 30- by 66-inches. Loads are dropped before parachutists. Loads followed immediately by parachutists are rigged with parachutes having non-breakaway static lines. When the load is dropped from the paratroop door, the largest dimension will be placed in the upright position. The parachute must be placed on top of the load, or toward the inside of the aircraft.

b. **Ramp Loads.** A-7A and A-21 containers may be dropped off the cargo ramp of C-130 aircraft. When using the ramp the skid board must be at least 42-inches in width. A-22 containers may also be dropped from the cargo ramp of C-17 and C-130 aircraft in a single or double stick, but the skid board must be 48-inches in width. The number of containers dropped will vary depending on the type of aircraft and the skid board size (see Table 2-2 or 2-3). The maximum height of a container must not exceed 83 inches for C-130 and 101 inches for C-17. The width of the container must not exceed 48 inches.

## MARINE CORPS AIRCRAFT

2-3. The C-130 and CH-53 aircraft can deliver container loads from the paratroop door or from the cargo ramp.

a. **C-130 Aircraft.** The Marine Corps C-130 uses the same procedure and has the same capability as the Air Force C-130.

b. **CH-53 (Sea Stallion) Helicopter.** The CH-53E assault support helicopter is a class 2 aircraft equipped with a seven-blade main rotor and a four-blade canted tail rotor. It is designed for land- and ship-based operations, with an emergency water operating capability. The helicopter is equipped with a rear ramp loading system, cargo winch, roller conveyors, and cargo tie-down facilities. External cargo may be suspended from hooks using either single- or two-point suspension systems. Maximum weight on wheels is 69,750 pounds. Maximum allowable gross weight is 73,500 pounds. Refer to NAVAIR A1-H53BE-NFM-000 Part XI Performance Data for specific capabilities. Inboard cabin compartment floor is limited to static loads of 300 pounds per square foot. Outboard sections of the floor are stressed to greater loads at various positions (Refer to NAVAIR A1-H53BE-NFM-000, Page 2-105). Roller conveyor limits are generally limited to 2200 pounds. The maximum usable cabin height is 73-inches. The maximum usable cabin length is 336-inches. The maximum usable cabin width is 76-inches. The maximum airdrop weight is 2,200 pounds. The tie-down fittings vary in capacity between 4,400 pounds and 20,000 pounds. Specifics can be found in the Cargo Loading Manual NAVAIR A1-H53BE-CLG-000.

**NOTES:**

1. Loads to be followed immediately by parachutists must be rigged, unless specified, with parachutes having non-breakaway static lines.
2. High-velocity CDS dropped over 10,000 feet mean sea level will be rigged with a breakaway static line.
3. High-velocity CDS dropped under 10,000 feet mean sea level will be rigged with a non-breakaway static line.

**Table 2-2. C-130 Aircraft CDS Capabilities**

CDS Skid Dimension	Non-CVRS	CVRS
48- by 48-inch	Only single stick, 1-8 containers.	Single or double stick, 1-16 containers. Must be dropped in even numbers when dropping double stick.
48- by 72-inch stretch container	Only single stick, 1-6 stretch containers	Single or double stick, 1-12 stretch containers. Must be dropped in even numbers when dropping double stick.
48- by 96-inch double A-22 container	Only single stick, 1-4 double containers	Single or double stick, 1-8 double containers. Must be dropped in even numbers when dropping double stick.

**NOTES:**

1. If the loads have a front or rear overhang, the number of containers will be reduced.
2. When steel strapping is bound around the skid board, non-CVRS must be used.

**CENTERLINE VERTICAL RESTRAINT SYSTEM**

2-4. The CVRS was designed to restrain container loads vertically in Air Force aircraft.

a. **Description.** The CVRS is designed to work with the dual rail system in Air Force aircraft. It adds a rail in the center of the cargo area. The rail runs from the front of the cargo area of the aircraft to the rear and is bolted in place. Aircraft without the CVRS in place may be loaded with containers in a single stick formation in the center of the cargo area of the aircraft. Aircrafts with the CVRS installed may be loaded with A-22 containers positioned in a right stick formation, left stick formation, or both; however, container skid boards must be 48-inches in width and must be 1-inch thick if the rigged weight is 1,600 pounds or greater. On aircraft with the CVRS in place, when an A-22 container is being positioned in the right stick, the right edge of the skid is positioned in the right rail of the aircraft dual rail system and the left edge of the skid is positioned in the center rail. The left stick is loaded in a similar manner. On aircraft with the CVRS in place, each stick of containers is independent of the other.

**NOTE:** Any overhang must be placed lengthwise in the aircraft. If the container load has an overhang on three or four sides, the load must be dropped in a centerline configuration (non-CVRS).

b. **Capabilities.** Air Force aircraft equipped with the CVRS can drop single or double A-22 container loads in a single or double stick formation. Both sticks may be released simultaneously, or each stick can be dropped separately. All containers in a stick may be dropped on the same drop zone, or any combination of containers may be dropped on different drop zones. A separate release gate is required for each container or group of containers in each stick to be dropped on a separate drop zone. See Table 1-3 for release gate requirements.

## NON-CVRS LOADS

2-5. The CVRS was designed to restrain the load vertically during the aircraft flight. When the load is not restrained to CVRS standards, it must be vertically restrained for flight. These restraints will be removed up to 30 minutes before airdrop. After the restraints are removed, the aircraft will have reduced maneuverability for threat avoidance.

## INBOARD LOGISTICS RAIL

2-6. The inboard logistics rail was designed to restrain container loads vertically in the C-17 aircraft.

a. **Description.** The inboard logistics rail is a permanent rail in the center of the C-17 aircraft cargo area. It runs from the front of the cargo area to the rear and folds down when not in use. The aircraft may be loaded with A-22 containers positioned in the right stick formation, left stick formation, or both; however, container skid boards must be 48-inches in width and must be 1-inch thick if the rigged weight is 1,600 pounds or greater. When A-22 containers are being positioned in the right stick, the right edge of the skid is positioned in the right rail of the aircraft aerial delivery system rail and the left edge of the skid is positioned in the inboard logistics rail. The left stick is loaded in a similar manner. Each stick of containers is independent of each other.

**NOTE:** The width of the container load **MUST NOT** exceed 48 inches.

b. **Capabilities.** The C-17 aircraft can drop single or double A-22 container loads in either a single or double stick configuration, but double sticks must have an even number of containers. Both sticks may be released simultaneously, or each stick can be dropped separately. All containers in a stick may be dropped on the same drop zone, or any combination of containers may be dropped on different drop zones. A separate release gate is required for each container or group of containers in each stick to be dropped on a separate drop zone. See Table 1-3 for release gate requirements.

**Table 2-3. C-17 Aircraft CDS Capabilities**

CDS Skid Dimension	Inboard Logistics Rail
48- by 48- inch	Single or double stick, 1-40 containers. Must be dropped in even numbers when dropping double stick.
48- by 72-inch stretch container	Single or double stick, 1-20 stretch containers. Must be dropped in even numbers when dropping double stick.
48- by 96-inch double A-22 container	Single or double stick, 1-20 double containers. Must be dropped in even numbers when dropping double stick.

**NOTE: If the loads have a front or rear overhang, the number of containers will be reduced.**

**This page intentionally left blank.**

PART TWO

RIGGING A-7A CONTAINER LOADS

Chapter 3

General Information and Procedures

A-7A AIRDROP CARGO SLING ASSEMBLY

3-1. The A-7A airdrop cargo sling assembly consists of four D-rings and four identical sling straps. Each strap is 188 inches long and has a friction adapter attached at one end. To rig an A-7A container two or more straps are required. Figure 3-1 shows an A-7A airdrop cargo sling assembly.

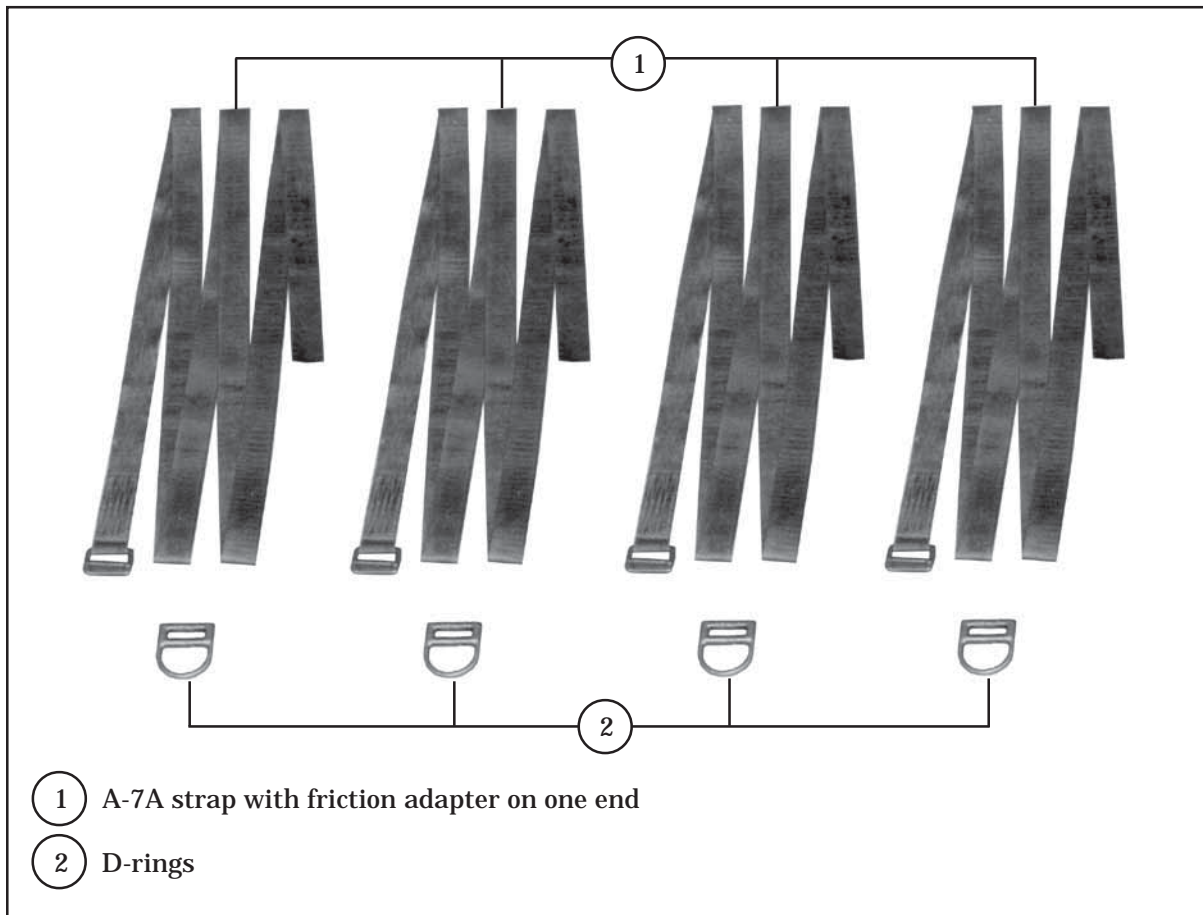


Figure 3-1. A-7A Airdrop Cargo Sling Assembly

## WEIGHT LIMITS

3-2. The maximum weight of this container will vary according to the number of straps, but must not exceed 500 pounds. When two straps are used, 300 pounds is the maximum weight. When three straps are used, 400 pounds is the maximum weight. When four or more straps are used, the maximum weight must not exceed 500 pounds. The minimum weight will vary according to the parachute used. When dropped from the paratroop doors, the load must weigh a minimum of 11 pounds per square foot. When dropped from the ramp, the load must weigh a minimum of 28 pounds per square foot. Table 3-1 lists parachutes used with this container and the weight restrictions.

**Table 3-1. Parachute Requirements for A-7A Container Loads**

Parachute	Suspended Weight (Pounds)	
	Minimum	Maximum
<b>Low-Velocity</b>		
One 68-inch pilot	30	50
Three 68-inch pilot	51	200
One T-10 modified cargo	90	500
One G-14 cargo	200	500
<b>High-Velocity</b>		
One 68-inch pilot	75	150
Three 68-inch pilot	151	500
*One 12-foot high-velocity	151	500
One 15-foot cargo extraction	151	500

\* Primary parachute

## A-7A CONTAINER LOADS

3-3. The A-7A loads can be rigged for low-velocity or high-velocity airdrop. The container can exit the aircraft either through the paratroop doors or off the ramp. The equipment should be padded with felt, cellulose wadding, or honeycomb. This container is usually used to supply small items, ready-to-use or disassembled equipment, or other nonfragile supplies. The load can be rigged by the using unit. The parachute must be packed by a parachute rigger. It is only required to be inspected by a jumpmaster or parachute rigger.

## PARACHUTES FOR A-7A LOADS

3-4. To select a parachute for an A-7A load, consider the type of airdrop (low-velocity or high-velocity) and the weight of the rigged container, shown in Table 3-1. Pack and install the parachute as described below.



a. **LOW-VELOCITY LOADS.** The parachutes that can be used to rig an A-7A load for low-velocity airdrop are described below.

(1) **One 68-inch pilot parachute.** Pack one 68-inch pilot parachute in accordance with TM 10-1670-281-23&P/TO 13C5-32-2/NAVAIR 13-1-32. Install the parachute as shown in Figure 3-2.

(2) **Three 68-inch pilot parachutes.** Pack three 68-inch pilot parachutes in accordance with TM 10-1670-281-23&P/TO 13C5-32-2/NAVAIR 13-1-32. Install the parachutes as shown in Figure 3-3.

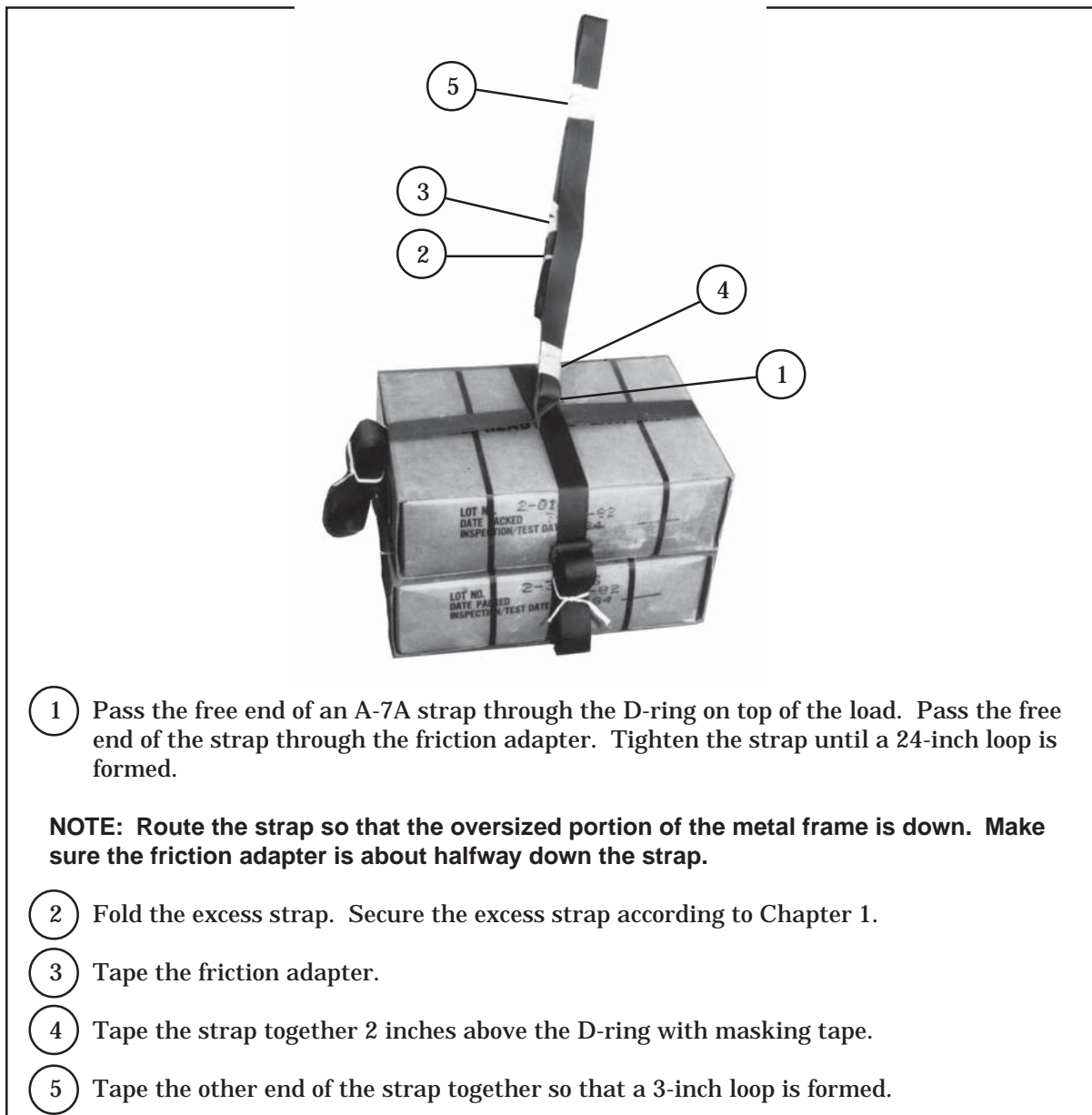
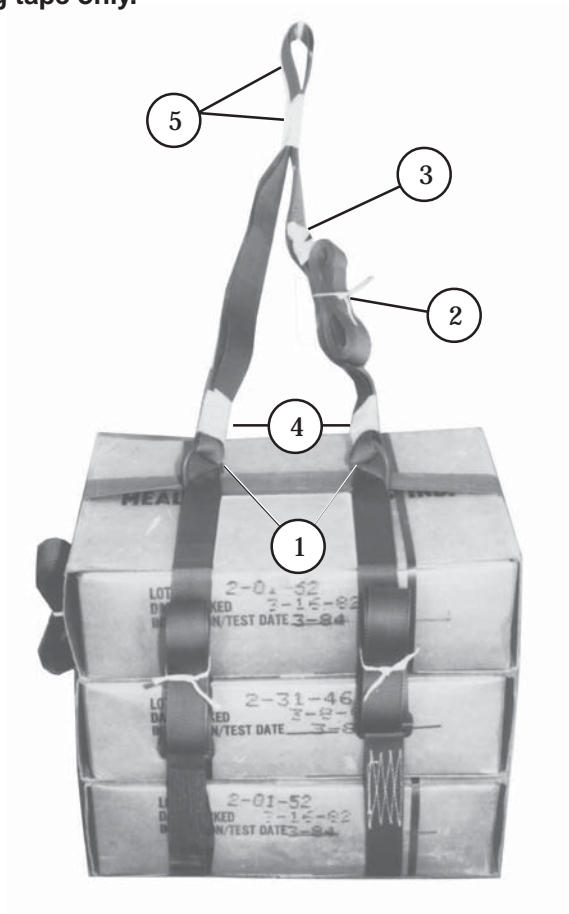


Figure 3-2. One 68-inch Pilot Parachute Installed

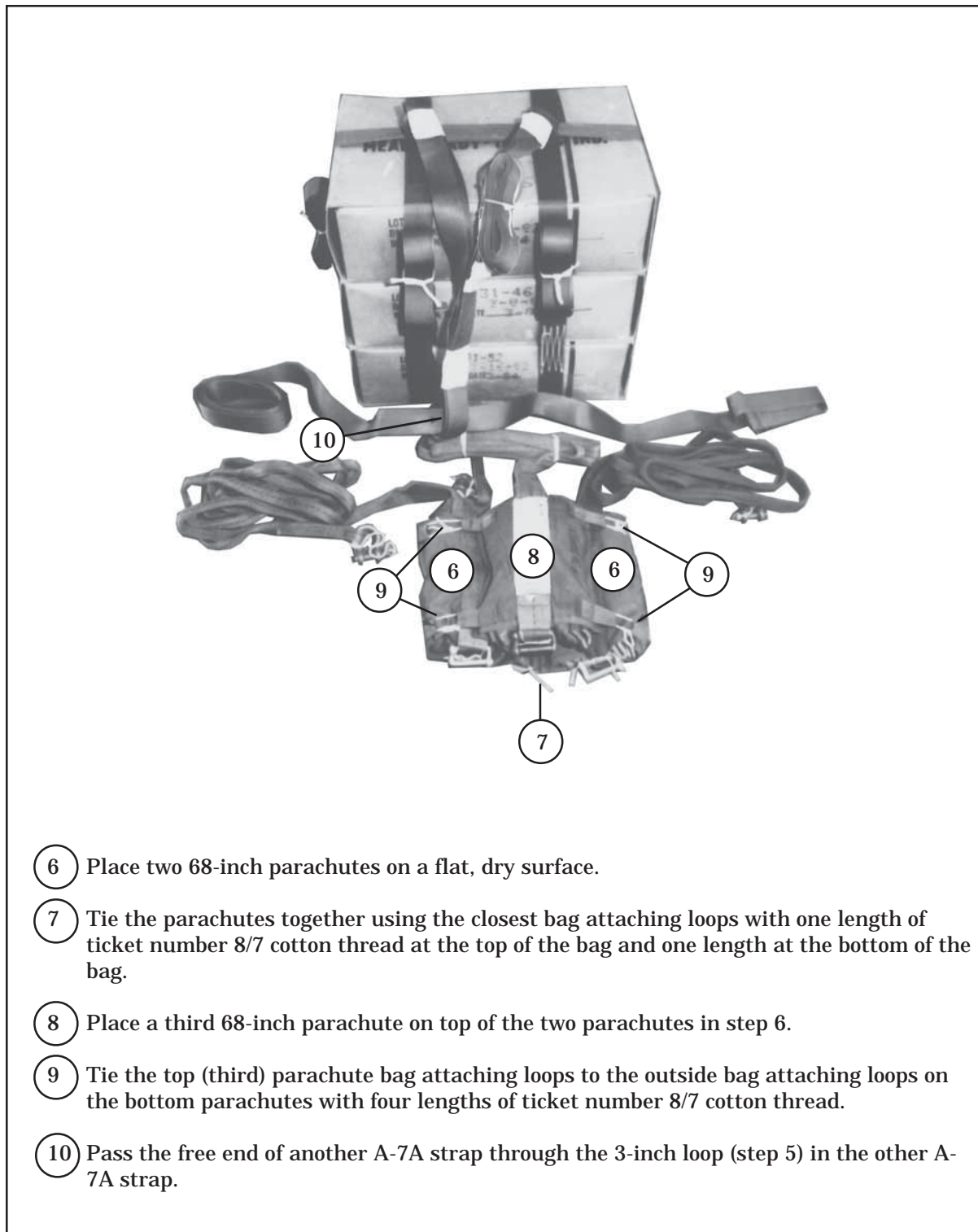


**NOTE: Use masking tape only.**



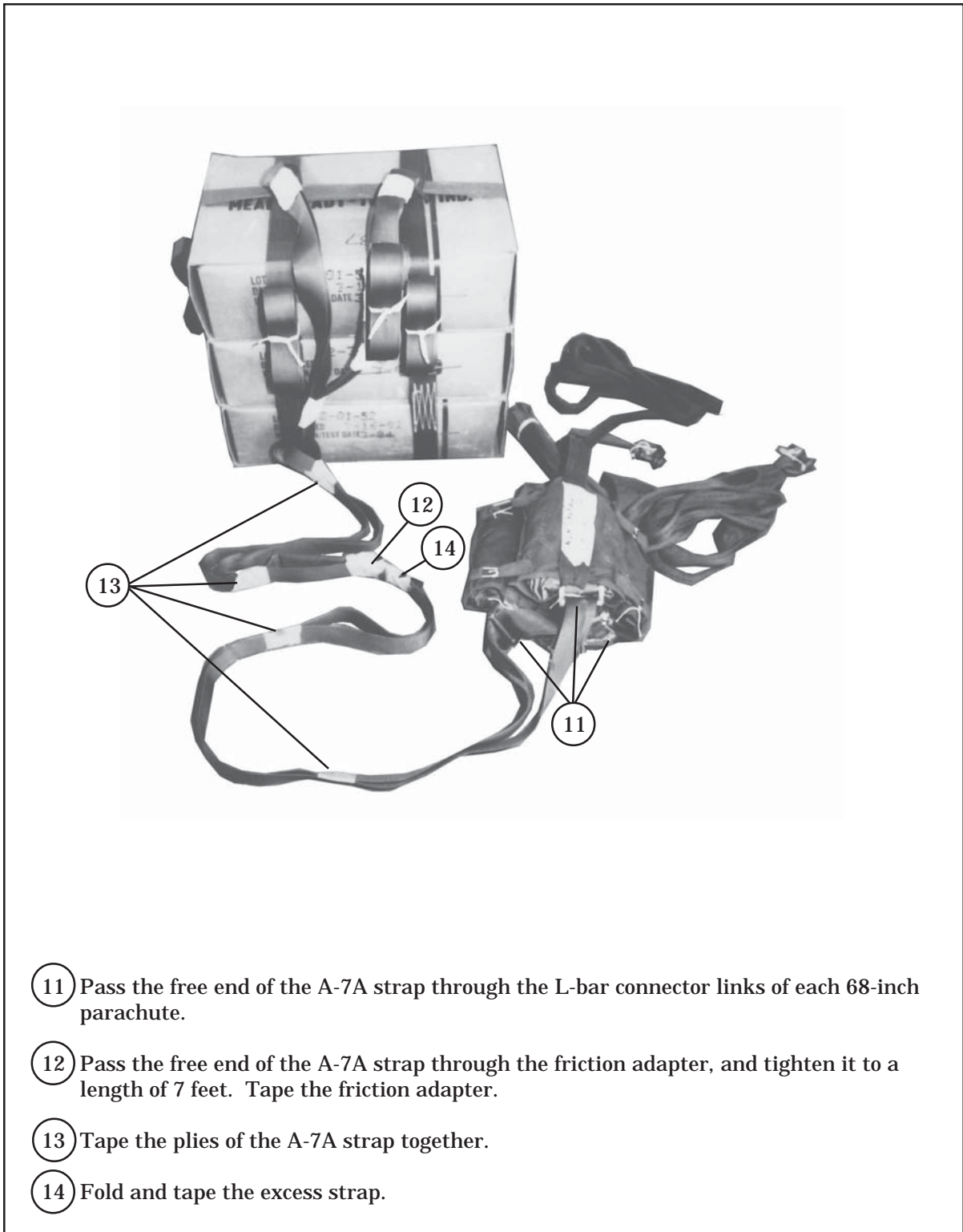
- ① Pass the free end of an A-7A strap through the two D-rings on top of the load. Pass the free end of the strap through the friction adapter. Pull both plies of the strap upward between the D-rings. Tighten the strap until the two plies of the strap are 24 inches above the load.
- ② Fold the excess strap. Secure the excess strap according to Paragraph 1-14.
- ③ Tape the friction adapter with masking tape.
- ④ Tape the A-7A strap together 2 inches above each D-ring.
- ⑤ Form a 3-inch loop in the center of the A-7A strap. Tape the plies of the strap together below the loop.

**Figure 3-3. Three 68-inch Pilot Parachutes Installed**



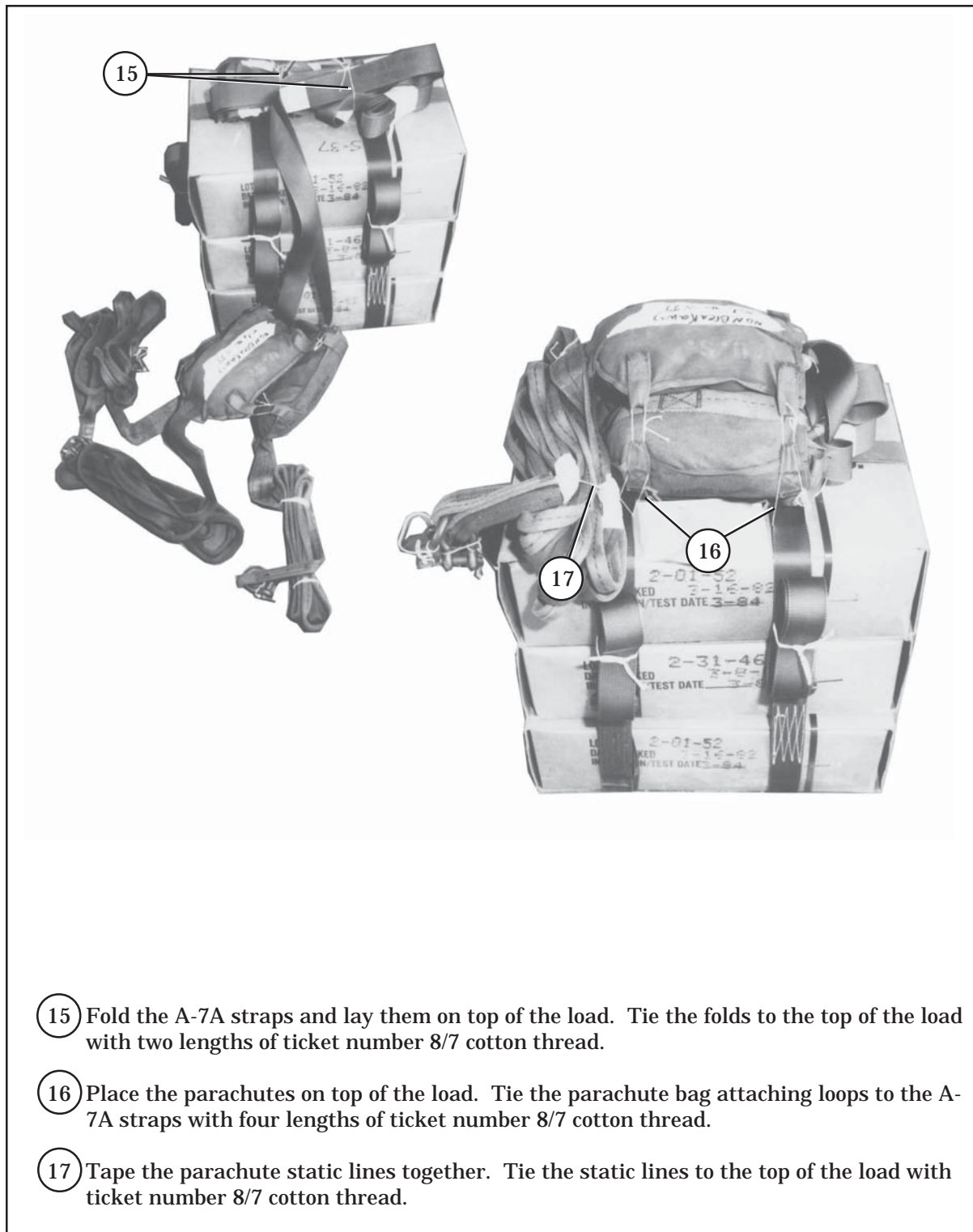
- ⑥ Place two 68-inch parachutes on a flat, dry surface.
- ⑦ Tie the parachutes together using the closest bag attaching loops with one length of ticket number 8/7 cotton thread at the top of the bag and one length at the bottom of the bag.
- ⑧ Place a third 68-inch parachute on top of the two parachutes in step 6.
- ⑨ Tie the top (third) parachute bag attaching loops to the outside bag attaching loops on the bottom parachutes with four lengths of ticket number 8/7 cotton thread.
- ⑩ Pass the free end of another A-7A strap through the 3-inch loop (step 5) in the other A-7A strap.

**Figure 3-3. Three 68-inch Pilot Parachutes Installed (Continued)**



- ①① Pass the free end of the A-7A strap through the L-bar connector links of each 68-inch parachute.
- ①② Pass the free end of the A-7A strap through the friction adapter, and tighten it to a length of 7 feet. Tape the friction adapter.
- ①③ Tape the plies of the A-7A strap together.
- ①④ Fold and tape the excess strap.

**Figure 3-3. Three 68-inch Pilot Parachutes Installed (Continued)**



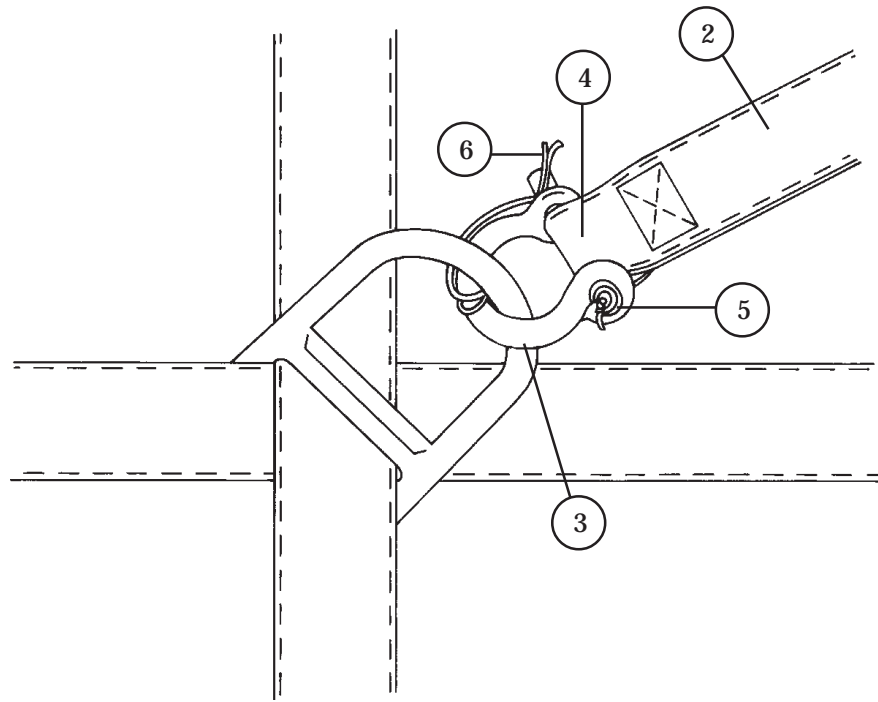
- 15 Fold the A-7A straps and lay them on top of the load. Tie the folds to the top of the load with two lengths of ticket number 8/7 cotton thread.
- 16 Place the parachutes on top of the load. Tie the parachute bag attaching loops to the A-7A straps with four lengths of ticket number 8/7 cotton thread.
- 17 Tape the parachute static lines together. Tie the static lines to the top of the load with ticket number 8/7 cotton thread.

Figure 3-3. Three 68-inch Pilot Parachutes Installed (Continued)

(3) **One T-10 Modified Cargo Parachute.** Pack one T-10 parachute according to TM 10-1670-293-23&P/TO 14D1-2-467-2. Install the parachute as shown in Figure 3-4 to attach the T-10 modified cargo parachute.

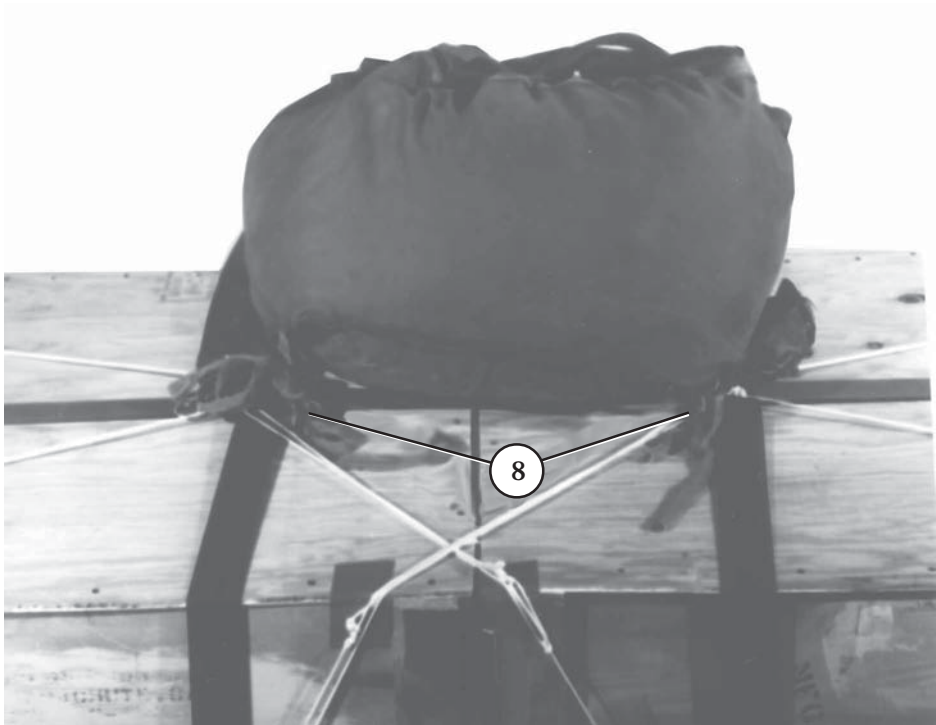
(4) **One G-14 Cargo Parachute.** Pack one G-14 cargo parachute according to TM 10-1670-282-23&P/TO 13C5-30-2/NAVAIR 13-1-33. Install the parachute as shown in Figure 3-4.

NOTE: This drawing is not drawn to scale.



- ① Place the parachute on top of the load between the D-rings (not shown).
- ② Pull each riser to the closest D-ring.
- ③ Place the bell portion of the clevis on one D-ring.
- ④ Place the loop on the end of the riser between the clevis arm.
- ⑤ Insert the clevis pin through the hole in the clevis arm, through the loop on the riser, and through the hole in the other clevis arm.
- ⑥ Insert the cotter pin in the hole of the clevis pin. Spread the ends of the cotter pin enough to prevent the cotter pin from sliding out of the clevis pin.
- ⑦ Attach the other riser to the other D-ring as described in steps 3 through 6.

Figure 3-4. G-14 Cargo Parachute Installed



8 Tie the parachute tie tapes to convenient points on the load with bow knots.

Figure 3-4. G-14 Cargo Parachute Installed (Continued)



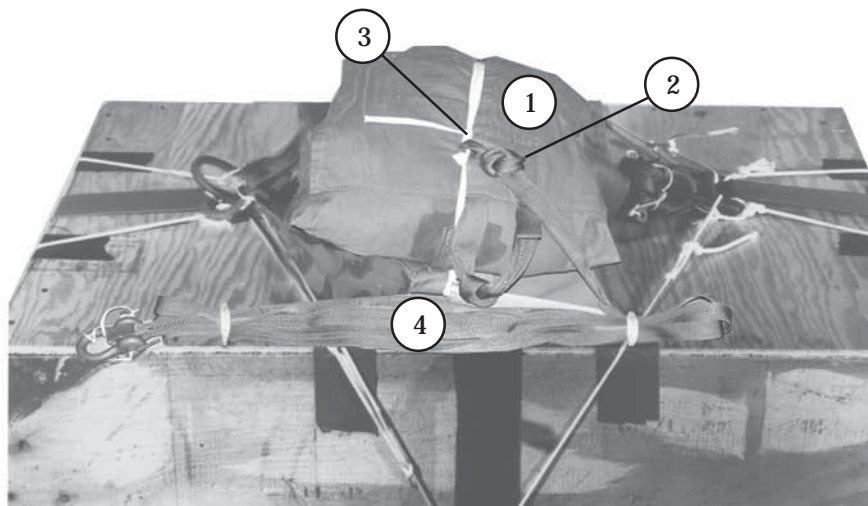
b. **HIGH-VELOCITY LOADS.** The parachutes that can be used to rig an A-7A load for high-velocity airdrop are described below.

(1) **One 68-inch Pilot Parachute.** Pack and install one 68-inch pilot parachute as described in paragraph 3-4a(1).

(2) **Three 68-inch Pilot Parachutes.** Pack and install three 68-inch pilot parachutes as described in paragraph 3-4a(2).

(3) **One 12-foot, High-Velocity Cargo Parachute.** Pack one 12-foot high-velocity cargo parachute according to TM 10-1670-275-23&P/TO 13C5-25-2/NAVAIR 13-1-26. Install the parachute as shown in Figure 3-5.

(4) **One 15-foot Cargo Extraction Parachute.** When the 15-foot cargo extraction parachute is used, modify the parachute as shown in Figure 3-6. Install parachute as shown in Figure 3-7.



- ① Center the parachute and attach risers to D-rings as described in Figure 3-4, steps 1 through 7.
- ② Form a 3-inch diameter loop in the static line by tying an overhand knot approximately 8 inches up from the deployment bag main strap attaching loop.
- ③ Tie one end of a length of type I, 1/4-inch cotton webbing to a convenient point on the load on top of the load. Route the free end of the cotton webbing through the retaining loop, through the loop in static line and around a convenient point on the load. Form a trucker's hitch knot to secure the parachute.
- ④ S-fold the static line on top of the load. Secure the folds to the load with a 2-inch retainer band.

Figure 3-5. 12-Foot High-Velocity Cargo Parachute

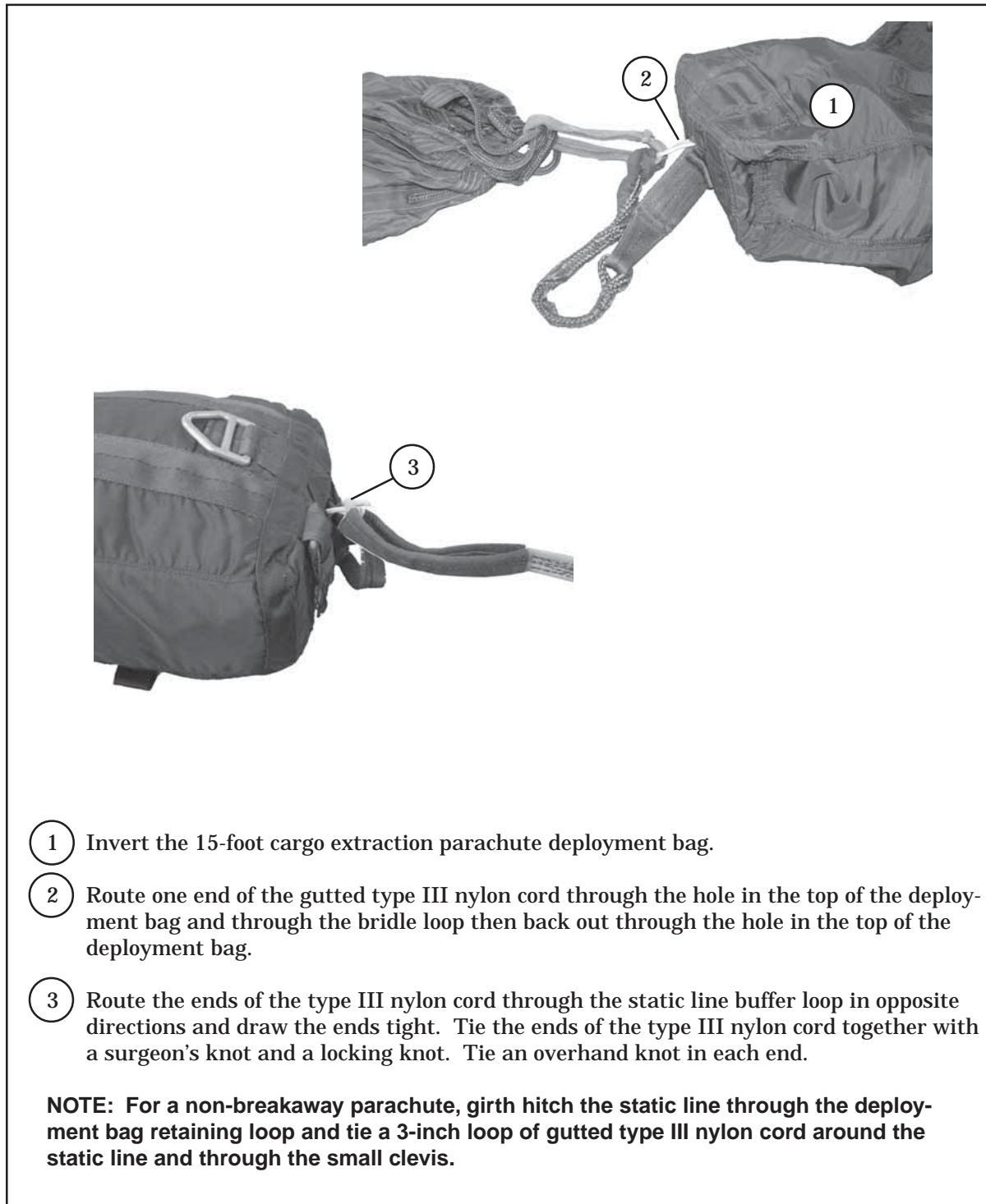
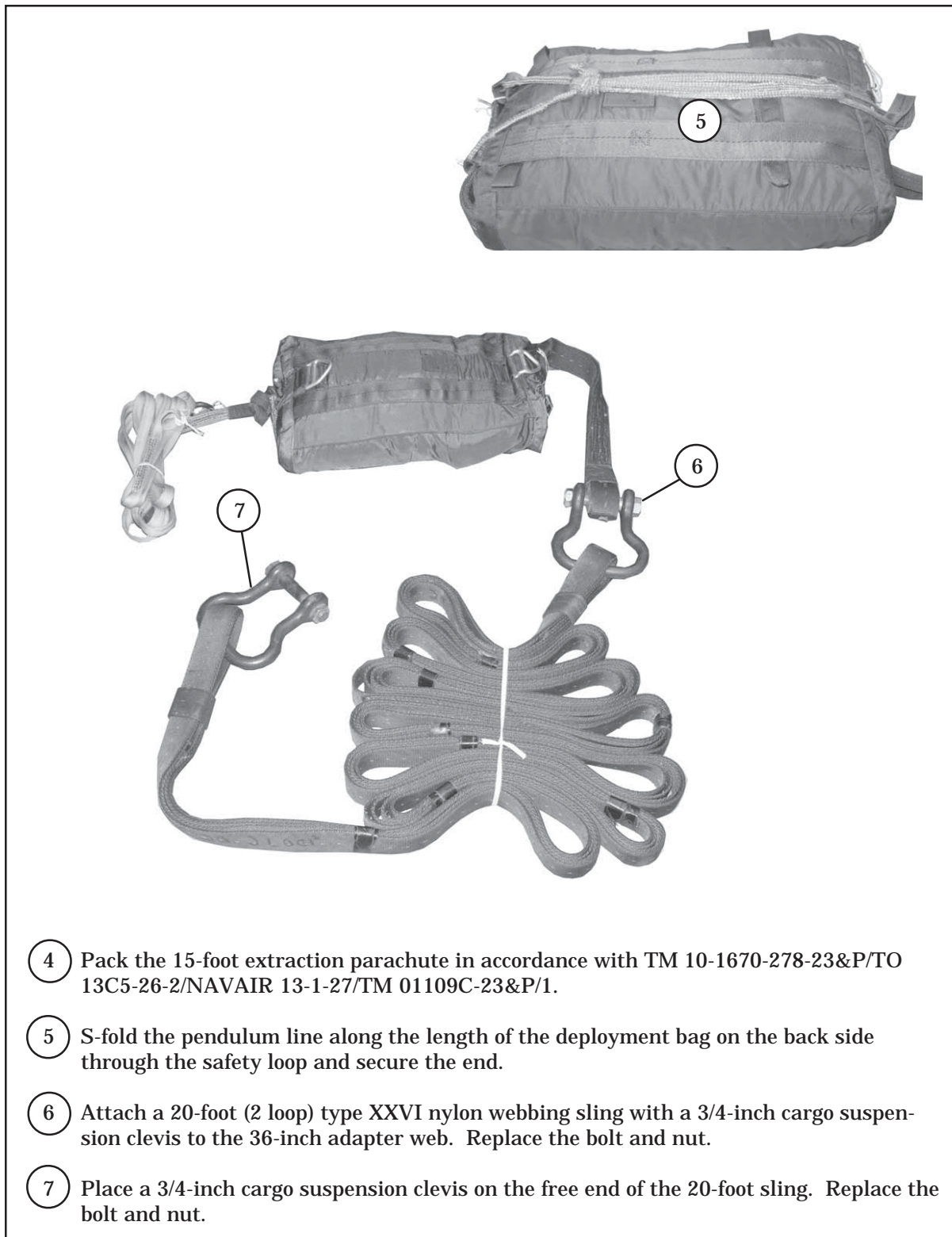
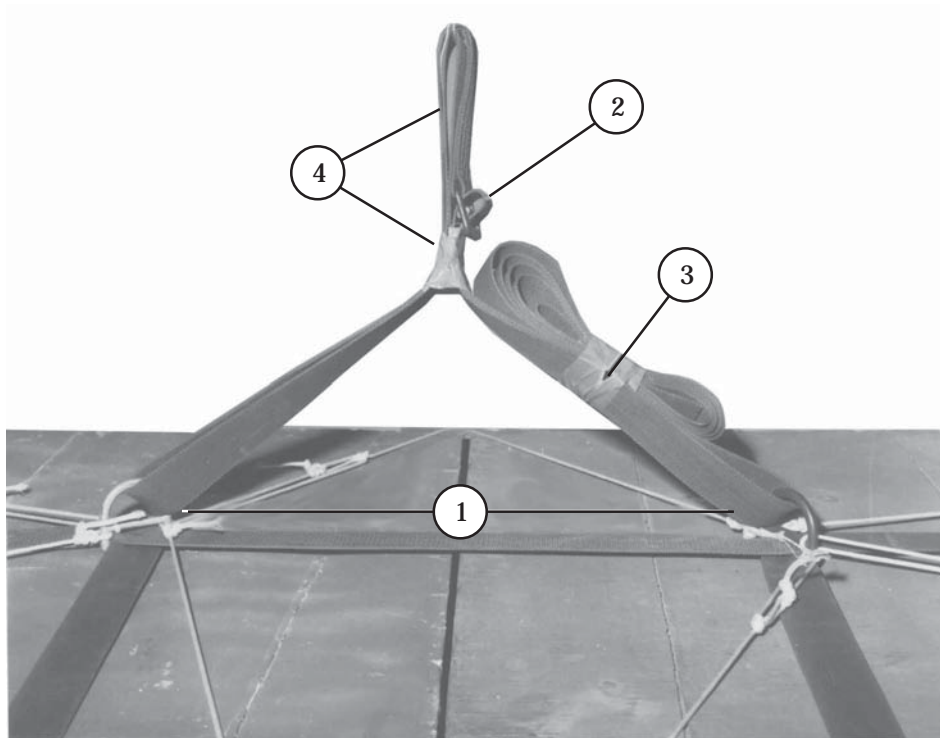


Figure 3-6. 15-Foot Cargo Extraction Parachute Modified

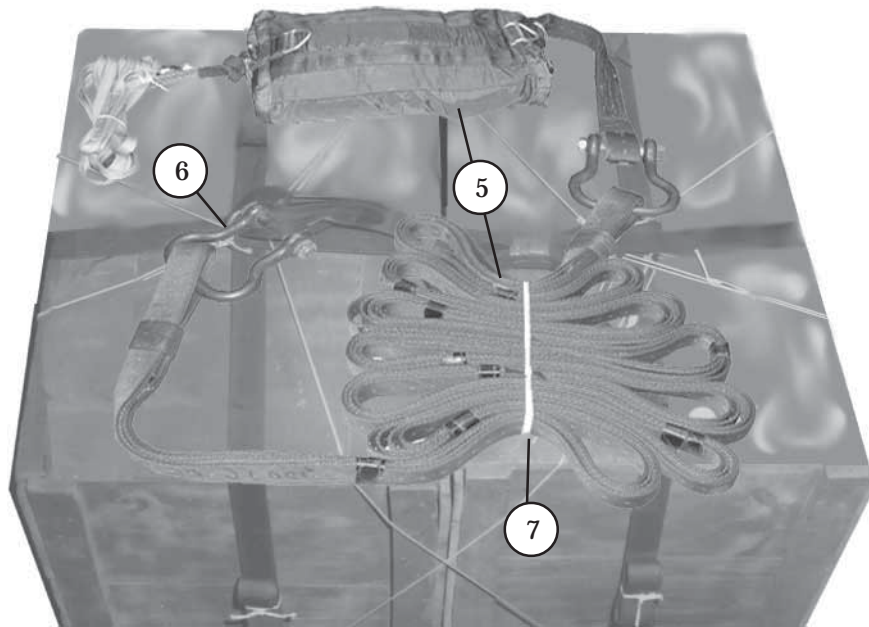


**Figure 3-6. 15-Foot Cargo Extraction Parachute Modified (Continued)**



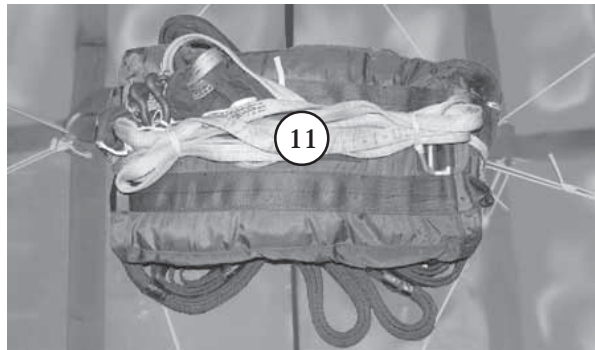
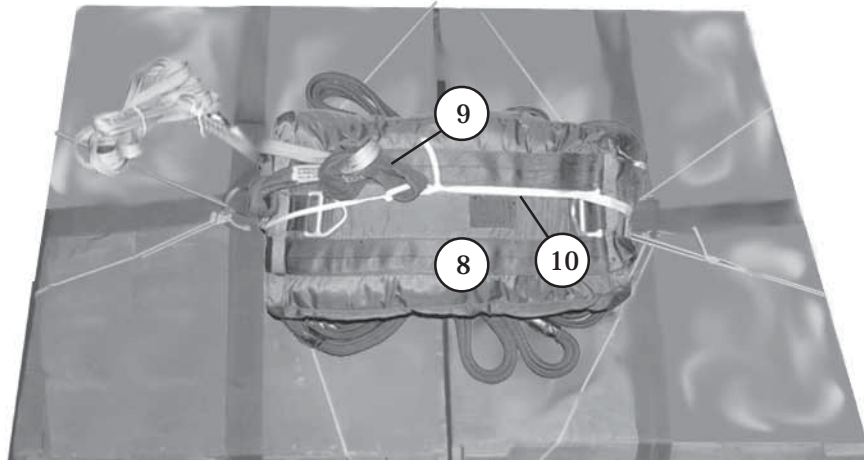
- ① Pass the free end of an A-7A strap through the two D-rings on top of the load.
- ② Fasten the strap with the friction adapter. Pull the end of the strap through the friction adapter until the double length of the strap is 24 inches long.
- ③ Fold the excess strap. Secure the folds to the strap with tape or type I, 1/4-inch cotton webbing.
- ④ Pull the two plies of the strap upward. Form a 6-inch loop in the center of the strap and tape the plies of the strap together below the loop.

**Figure 3-7. One 15-Foot Cargo Extraction Parachute Installed**



- ⑤ Place the modified 15-foot cargo parachute and the 20-foot sling on top of the load.
- ⑥ Place the loop formed in step 4 on the bolt of the cargo suspension clevis on the end of the 20-foot sling. Replace the nut.
- ⑦ Fold the 20-foot sling and tie the fold in place with suitable lengths of type I, 1/4-inch cotton webbing.

**Figure 3-7. One 15-Foot Cargo Extraction Parachute Installed (Continued)**



- ⑧ Center the sling and the parachute on the load.
- ⑨ Form a 3-inch diameter loop in the static line by tying an overhand knot approximately 12 inches up from the deployment bag main strap attaching loop.
- ⑩ Tie one end of a length of type I, 1/4-inch cotton webbing to a convenient point on the load on the top of the load. Route the free end of the cotton webbing through the retaining loop, through the loop in static line and around a convenient point on the load. Form a trucker's hitch knot to secure the parachute.
- ⑪ Attach a 2-inch retainer band to each bent V-ring and S-fold the static line to the bent V-rings.

Figure 3-7. One 15-Foot Cargo Extraction Parachute Installed (Continued)

## **MODIFYING THE T-10 PARACHUTE**

3-5. The T-10 personnel parachute may be used as the recovery parachute on container loads weighing at least 90 pounds but not more than 500 pounds. However, the T-10 parachute must be modified to be used on container loads. Prepare the T-10 parachute as described below:

- a. Inspect the parachute according to TM 10-1670-293-23&P/TO 14D1-2-467-2.
- b. Construct the riser harness as shown in Figure 3-8.
- c. Modify the deployment bag and universal static line (USL) as shown in Figure 3-9.
- d. Modify the canopy and attach the risers as shown in Figure 3-10.
- e. Pack the parachute according to TM 10-1670-293-23&P/TO 14D1-2-467-2.
- f. Fold and secure the static line as shown in Figure 3-11.
- g. Required equipment to modify the T-10 parachute is shown in Table 3-2.

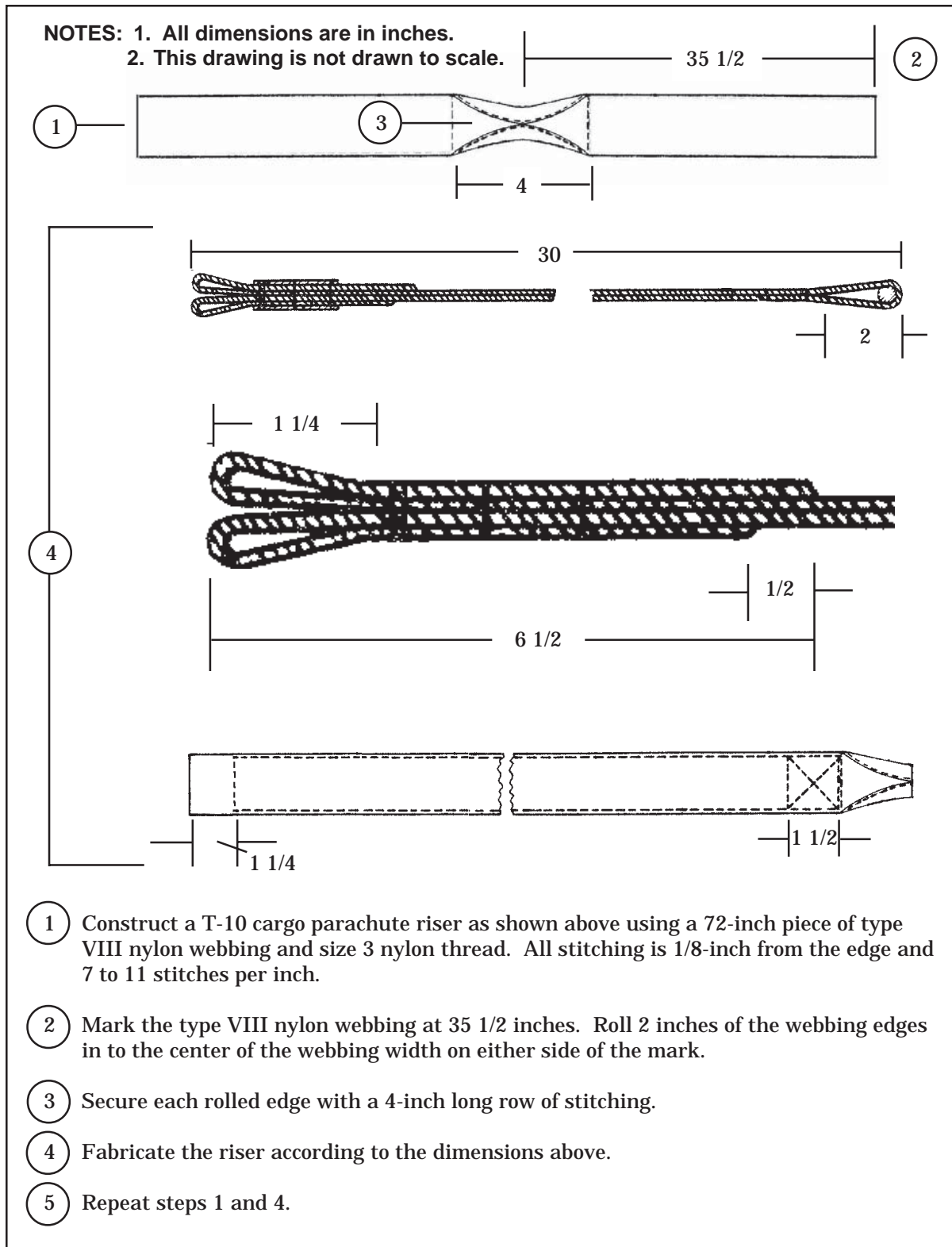


Figure 3-8. T-10 Cargo Riser Assembly Constructed



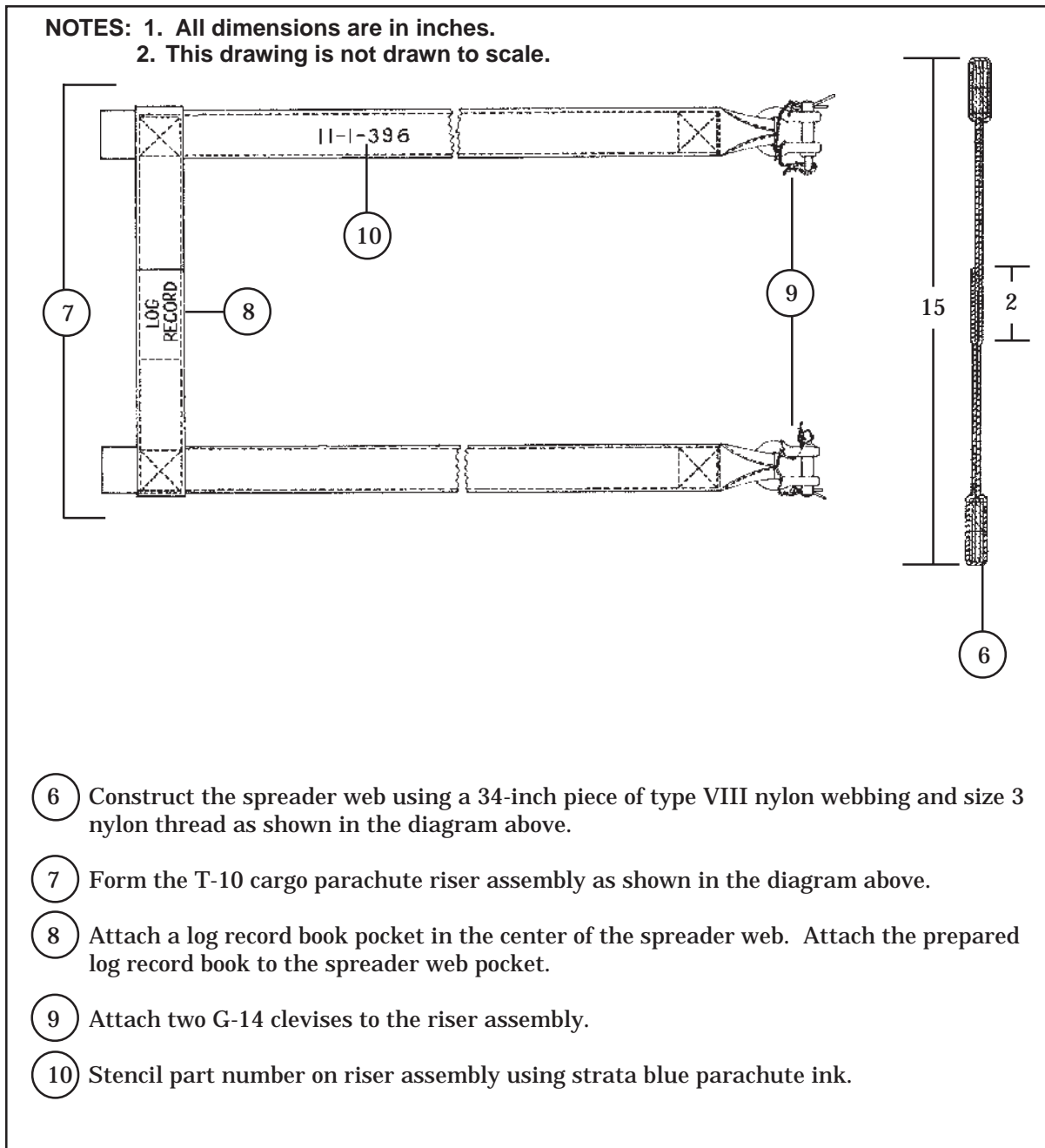


Figure 3-8. T-10 Cargo Riser Assembly Constructed (Continued)

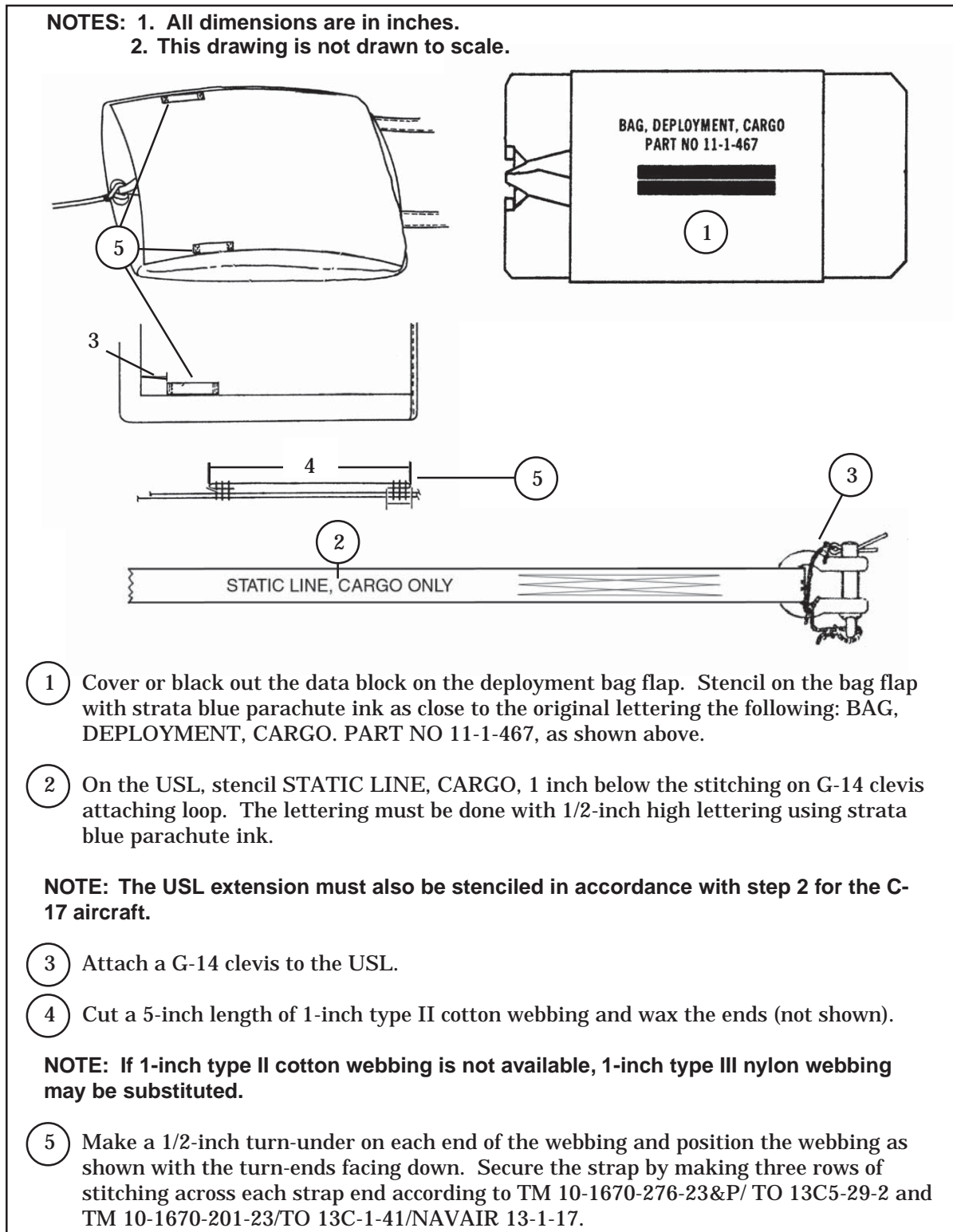
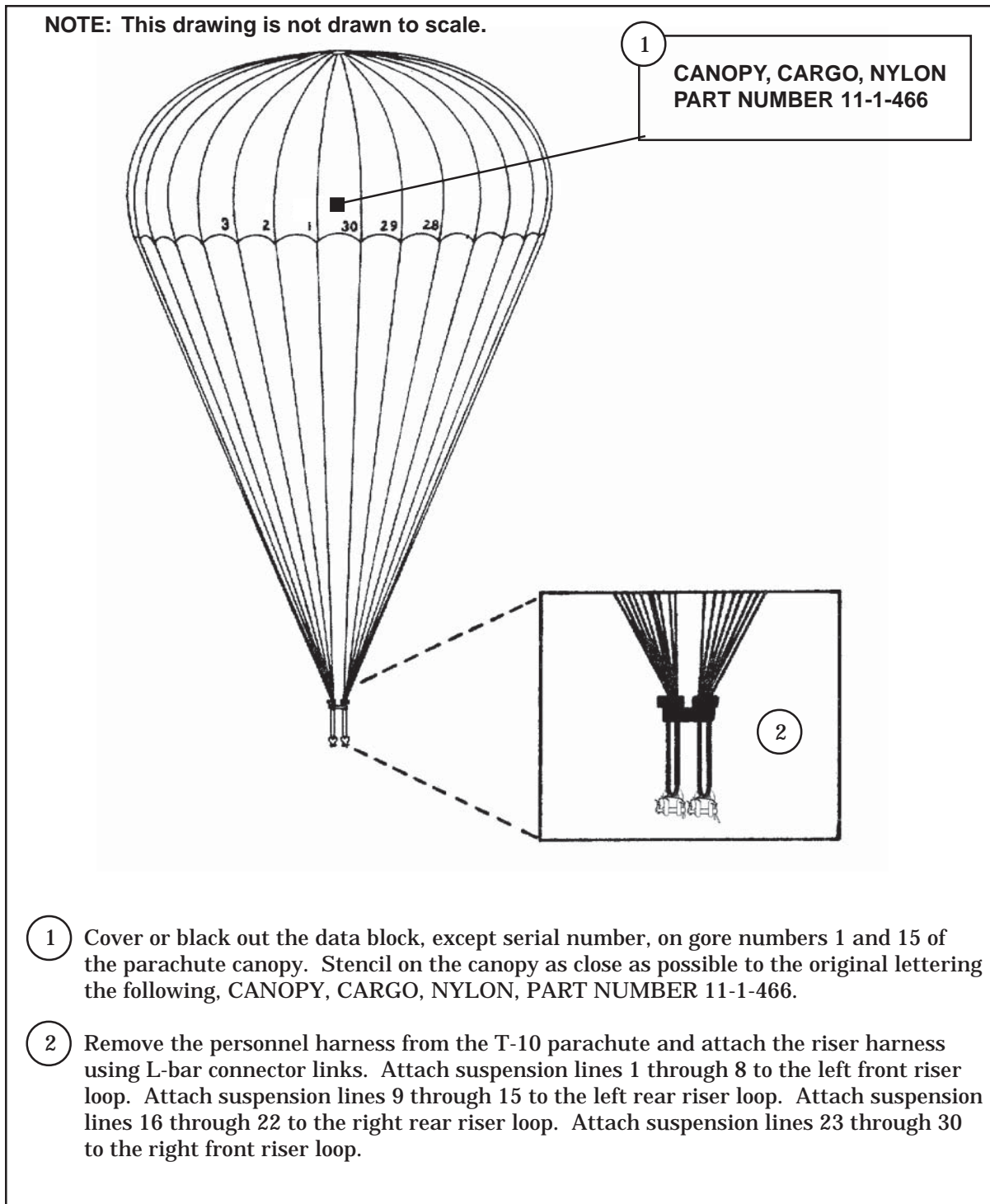
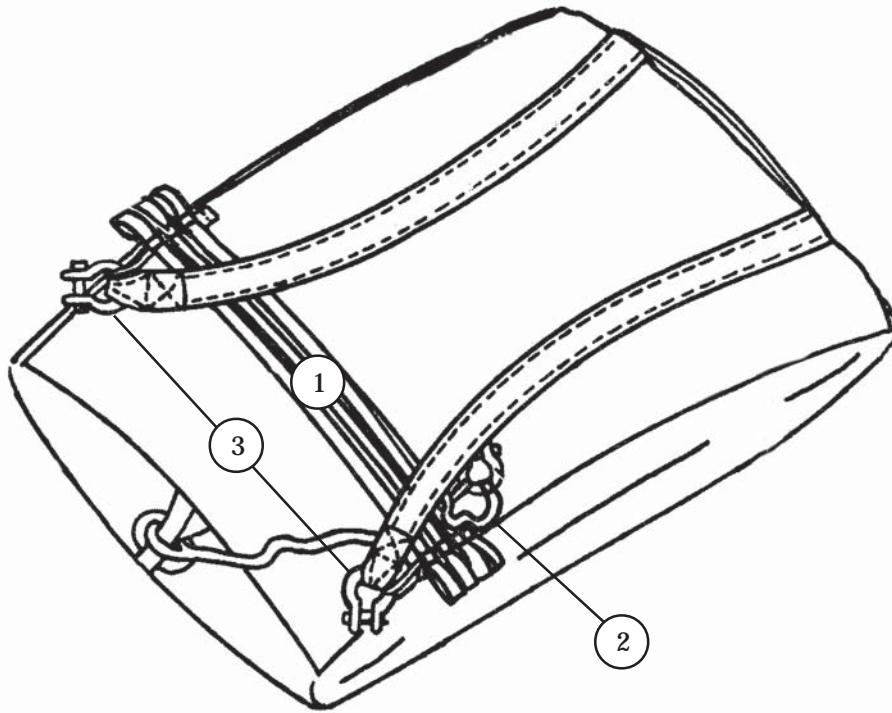


Figure 3-9. T-10 Cargo Deployment Bag and USL Modified



**Figure 3-10. T-10 Cargo Parachute Modified**

**NOTE:** This drawing is not drawn to scale.



- ① Fold the static line across the deployment bag. Secure the folds to the top retainer straps with retainer bands.
- ② Secure the static line clevis with a retainer band or ticket number 8/4 cotton thread.
- ③ Secure each G-14 clevis attached to the riser harness to the retainer straps with ticket number 8/4 cotton thread to store the parachute.
- ④ When installing the parachute on the load, secure the parachute to convenient points on the load as shown in Figure 3-7, steps 9 and 10.

**Figure 3-11. T-10 Cargo Parachute Static Line and Risers Secured**

**Table 3-2. Equipment Required For Modifying The T-10 Parachute**

National Stock Number	Item	Quantity
1670-01-476-3131	Bag, deployment	1
1670-01-247-7151	Canopy, 35-ft diam, T-10	1
1670-00-568-0323	Band, retainer	As required
4030-00-678-8560	Shackle, 3/8-in diam (G-14 clevis)	2
1670-01-476-3068	Static line, personnel (15-foot USL)	1
1670-01-476-3130	Static line, extension (5-foot USL)	1
8310-00-917-3944	Thread, cotton, ticket number 8/4	As required
8310-00-917-3945	Thread, cotton, ticket number 8/7	As required
8310-00-267-3027	Thread, nylon, size 3, olive drab (OD)	As required
	or	
8310-00-248-9714	Thread nylon, size 3, natural (NT)	As required
	Webbing:	
8305-00-268-2411	Cotton, 1/4-inch, type I	As required
8305-00-281-3315	Cotton, 1-inch, type II	As required
	or	
8305-01-062-7050	Nylon, 1-inch, type III	As required
8305-00-261-8585	Nylon, type VIII, OD	As required
	or	
8305-00-263-3591	Nylon, type VIII, NT	As required

**This page intentionally left blank.**

## Chapter 4

# Rigging Typical A-7A Containers

## SECTION I - LOW-VELOCITY AIRDROP FROM PARATROOP DOOR

### DESCRIPTION OF LOAD

4-1. Typical loads are rigged for low-velocity airdrop from a paratroop door of an aircraft. Typical loads may include rations, small equipment, water cans, or other supplies. Items should be padded and/or placed in boxes to prevent damage during airdrop. This load must not exceed 500 pounds, excluding the weight of the parachute. The minimum weight will vary according to the parachute. The maximum dimensions for this load is 48- by 30- by 66-inches including parachute. When the load is dropped, the largest dimension will be placed in an upright position in the door. The parachute will be on top or on the side located inside the aircraft. When the weight of the load exceeds 350-pounds, three trained designated pushers will assist the jumpmaster in pushing the load out.

### POSITIONING STRAPS

4-2. Position straps as shown in Figure 4-1. When two straps are used, a piece of type III nylon cord needs to be placed parallel to the bottom strap. When positioning straps, make sure the oversized portion of the metal frame on the friction adapter is up.

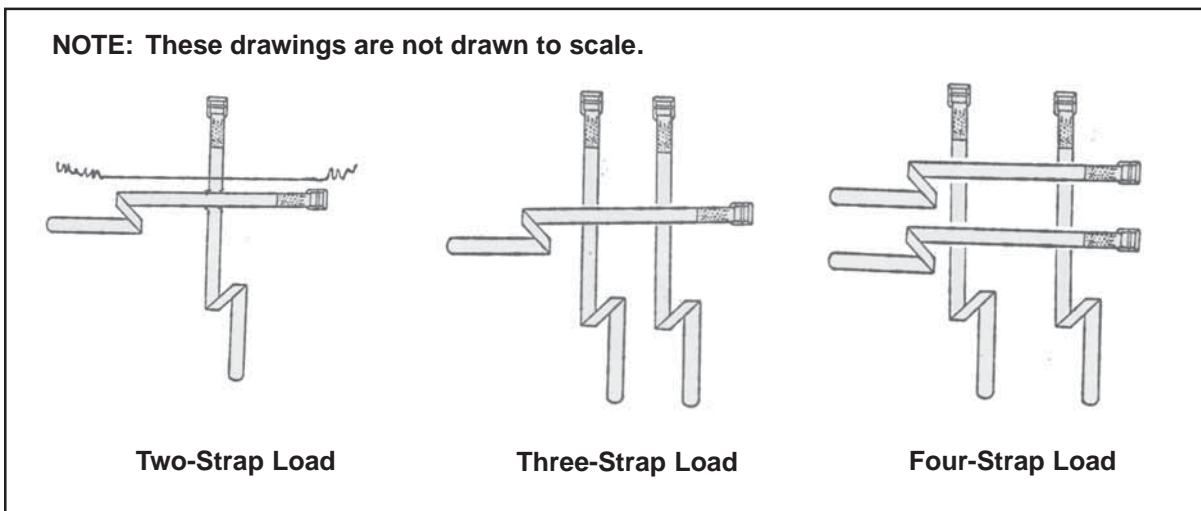
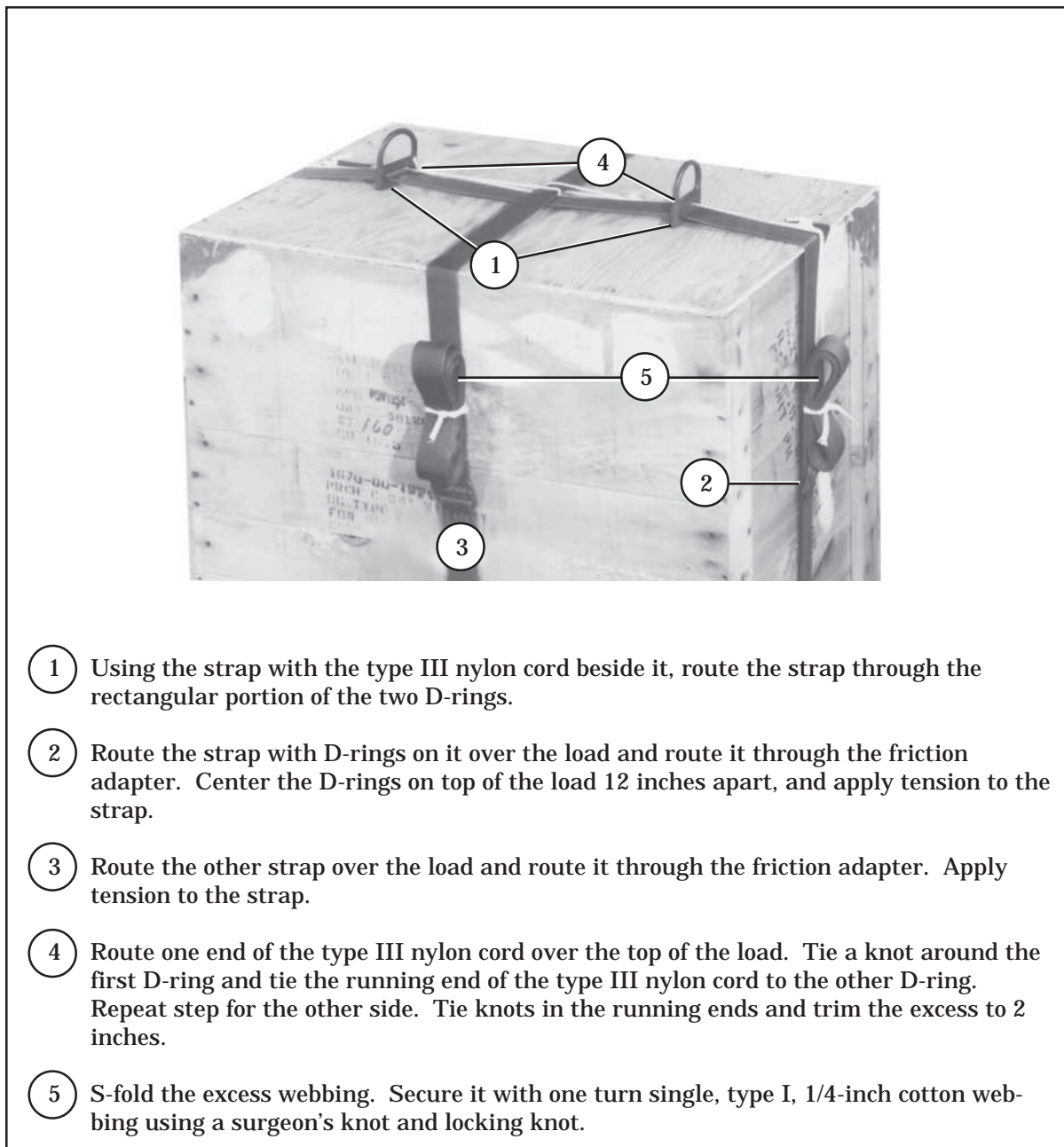


Figure 4-1. A-7A Straps Positioned

## POSITIONING LOAD AND SECURING STRAPS

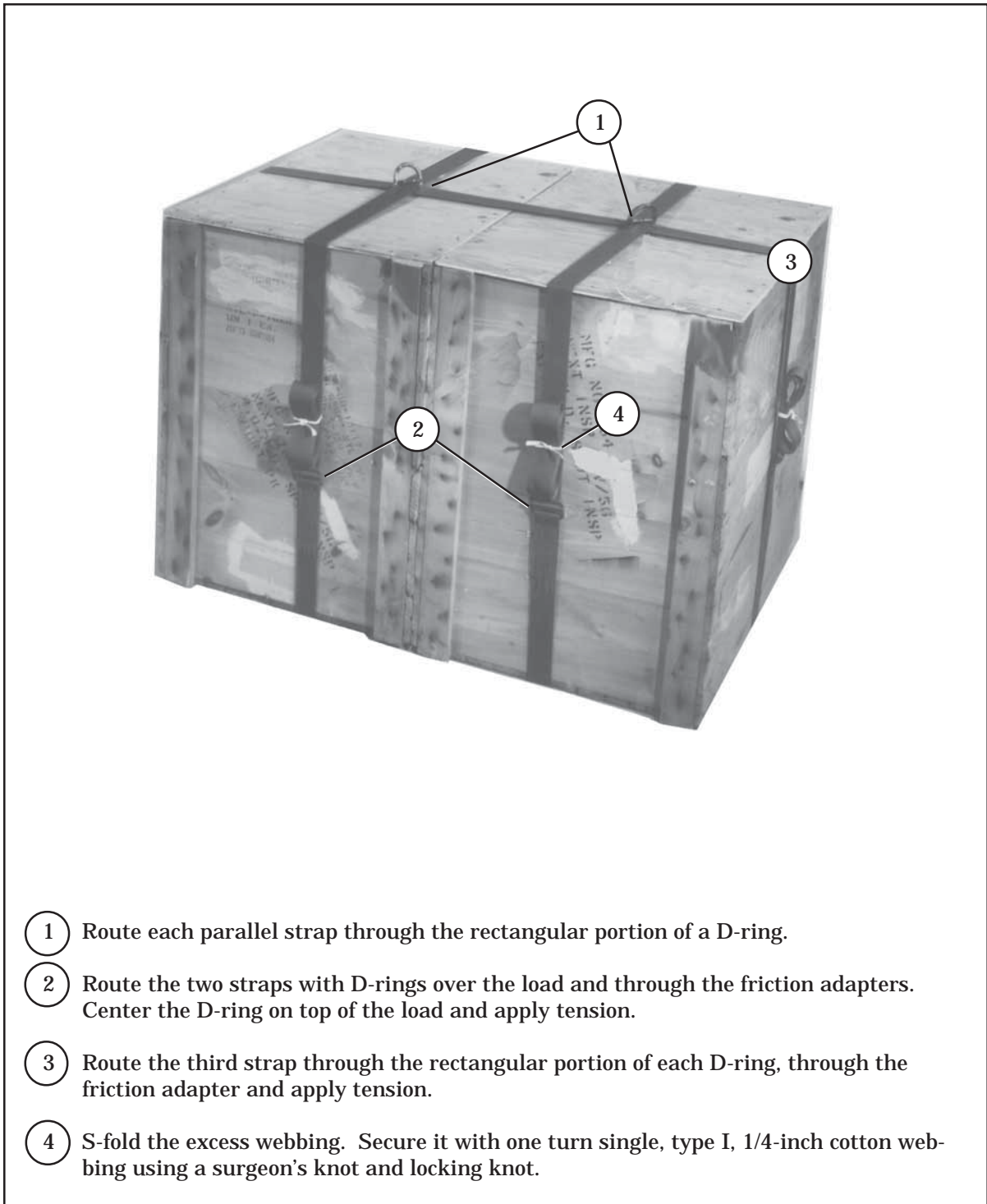
4-3. Center the equipment on the straps. If needed, honeycomb can be placed under the equipment. Secure the straps as shown in Figure 4-2 for a two-strap load, Figure 4-3 for a three-strap load, and Figure 4-4 for a four-strap load.



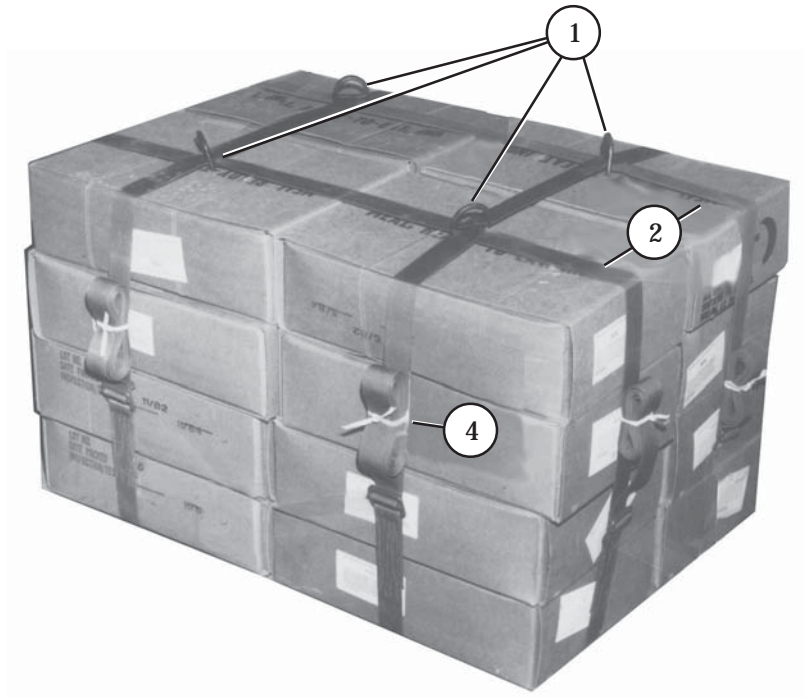
- ① Using the strap with the type III nylon cord beside it, route the strap through the rectangular portion of the two D-rings.
- ② Route the strap with D-rings on it over the load and route it through the friction adapter. Center the D-rings on top of the load 12 inches apart, and apply tension to the strap.
- ③ Route the other strap over the load and route it through the friction adapter. Apply tension to the strap.
- ④ Route one end of the type III nylon cord over the top of the load. Tie a knot around the first D-ring and tie the running end of the type III nylon cord to the other D-ring. Repeat step for the other side. Tie knots in the running ends and trim the excess to 2 inches.
- ⑤ S-fold the excess webbing. Secure it with one turn single, type I, 1/4-inch cotton webbing using a surgeon's knot and locking knot.

Figure 4-2. Two-Strap Load Positioned and Secured





**Figure 4-3. Three-Strap Load Positioned and Secured**



- ① Using two straps and four D-rings, route each strap through the rectangular portion of two D-rings and route the straps over the load and through the friction adapters. Ensure the D-rings are on top of the load.
- ② Using two additional straps for the sides, route one strap through the rectangular portion of the rear set of D-rings and through the friction adapters. Repeat with other strap through front set of D-rings.
- ③ Apply tension to all straps ensuring the D-rings stay in place.
- ④ S-fold the excess webbing. Secure it with one turn single, type I, 1/4-inch cotton webbing using a surgeon's knot and locking knot.

**NOTE:** Loads may need to be supported with either a piece of honeycomb or plywood to prevent boxes from collapsing.

Figure 4-4. Four-Strap Load Positioned and Secured

## INSTALLING PARACHUTE

4-4. Install a 68-inch parachute, T-10 modified cargo, or G-14 cargo parachute on the load according to Chapter 3.

## MARKING RIGGED LOAD

4-5. Mark the rigged load according to Paragraph 1-5. Compute the rigged load data for two-, three-, and four-strap loads as shown in Figure 4-5.

## EQUIPMENT REQUIRED

4-6. Use the equipment listed in Table 4-1 to rig a four-strap load for low-velocity airdrop as shown in Figure 4-5.

**Table 4-1. Equipment Required For Rigging the Four-Strap A-7A Load For Low-Velocity Paratroop Door Airdrop**

National Stock Number	Item	Quantity
4020-00-240-2146	Cord, nylon, type III	As required
8135-00-664-6958	Cushioning material, packaging, cellulose wadding	As required
1670-00-753-3928	Pad, energy-dissipating material, honeycomb	As required
1670-00-999-2658	Parachute, cargo, G-14	1
1670-00-251-1153	Sling assembly, cargo airdrop, A-7A	1
7510-00-266-6710	Tape, masking, 2-inch	As required
	Webbing:	
8305-00-268-2411	Cotton, 1/4-inch, type I	As required
8305-00-082-5752	Nylon, tubular, 1/2-inch	As required

**CAUTION**

Make the final rigger inspection required by FM 4-20.102/ NAVSEA SS400-AB-MMO-010/TO 13C7-1-5 and AR 59-4/OPNAVINST 4630.24C/AFJ 13-210(I)/MCO 13480.1B before the load leaves the rigging site.



**RIGGING LOAD DATA WITHOUT PARACHUTE**

Two-strap with one 68-inch parachute .....	30 - 50 pounds
with three 68-inch parachutes .....	51 - 200 pounds
with one T-10 modified parachute .....	90 - 300 pounds
with one G-14 cargo parachute .....	200 - 300 pounds
Three-strap with one 68-inch parachute .....	30 - 50 pounds
with three 68-inch parachutes .....	51 - 200 pounds
with one T-10 modified parachute .....	90 - 400 pounds
with one G-14 cargo parachute .....	200 - 400 pounds
Four-strap with one 68-inch parachute .....	30 - 50 pounds
with three 68-inch parachutes .....	51 - 200 pounds
with one T-10 modified parachute .....	90 - 500 pounds
with one G-14 cargo parachute (shown) .....	200 - 500 pounds

**Figure 4-5. Typical Four-Strap Load Rigged for Low-Velocity Paratroop Door Airdrop**

## SECTION II - LOW-VELOCITY AIRDROP FROM RAMP

### DESCRIPTION OF LOAD

4-7. A-7A containers can be rigged to be dropped off the ramp of an aircraft. The load is rigged the same as paratroop door drops but it must have a skid board attached. The skid board must project 2 inches beyond the C-130 aircraft's inboard roller channel. The minimum width of the skidboard for C-130 aircraft must be at least 42-inches. However, the skid board must be 48 inches wide for the C-17 and 48-inches wide for the C-130 when the CVRS is used. The weight range for ramp drops is 200 to 500 pounds without the weight of the parachute. The T-10 modified cargo or G-14 cargo parachute is the only parachute used on low-velocity ramp drops. Table 3-1 gives the weight ranges.

### PREPARING SKID BOARD

4-8. Prepare the skid board as shown in Figure 4-6.

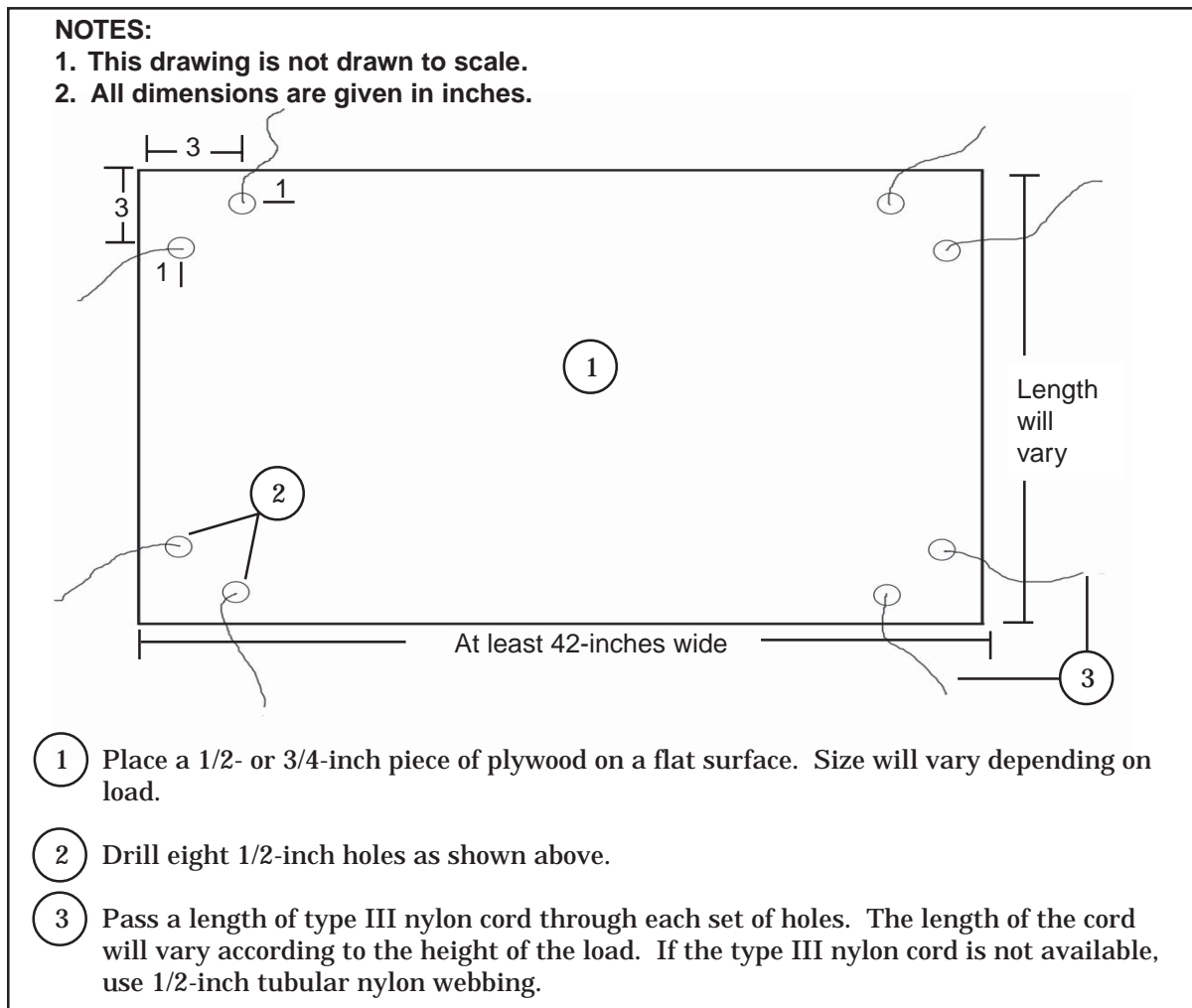


Figure 4-6. Skid Board Prepared

## PLACING HONEYCOMB AND POSITIONING STRAPS

4-9. Place the honeycomb on the skid board as shown in Figure 4-7. Position the straps as shown in Section I of this chapter.

## POSITIONING LOAD AND SECURING STRAPS

4-10. Position the load and secure the straps as shown in Section I of this chapter.

## SECURING SKID BOARD

4-11. Secure the skid board to a three-strap load as shown in Figure 4-8. Adapt the procedures in Figure 4-8 for a two-strap load. Secure the skid board to a four-strap load as shown in Figure 4-9.

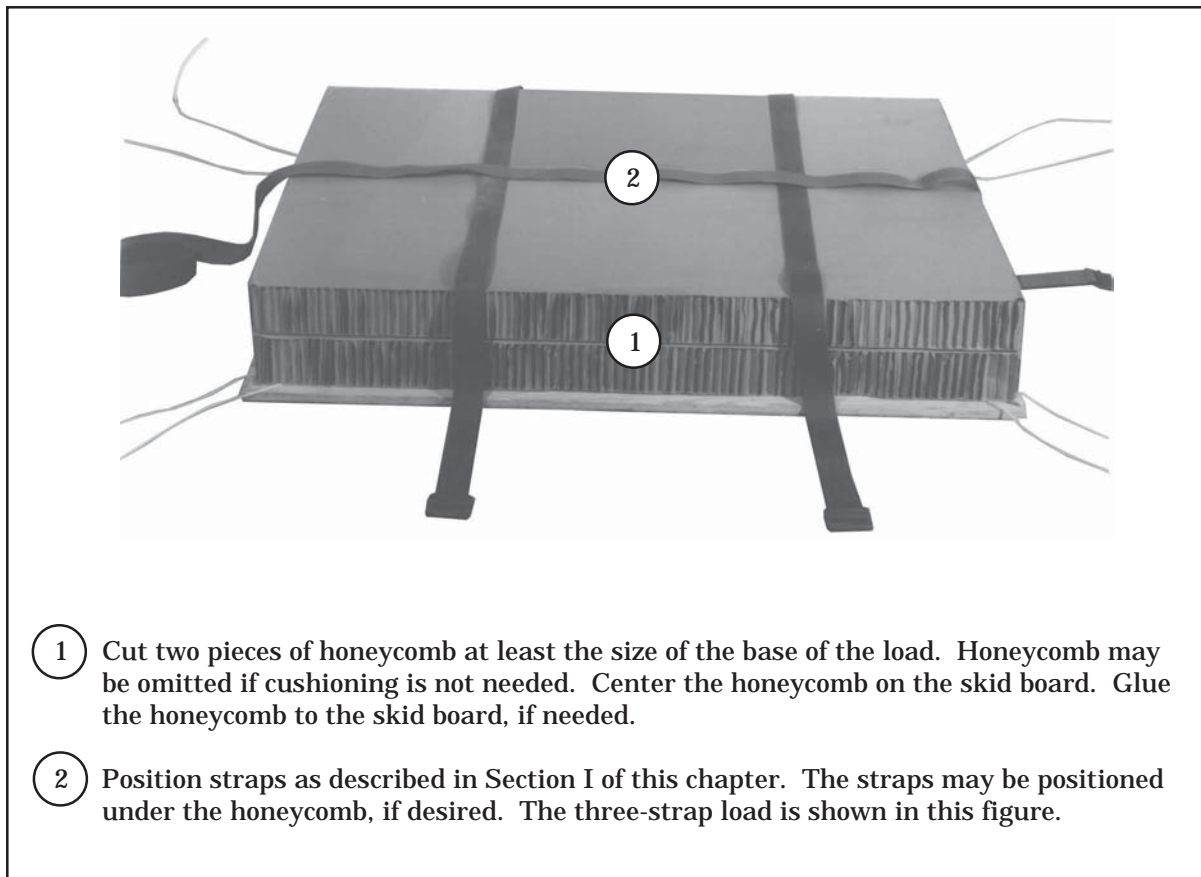
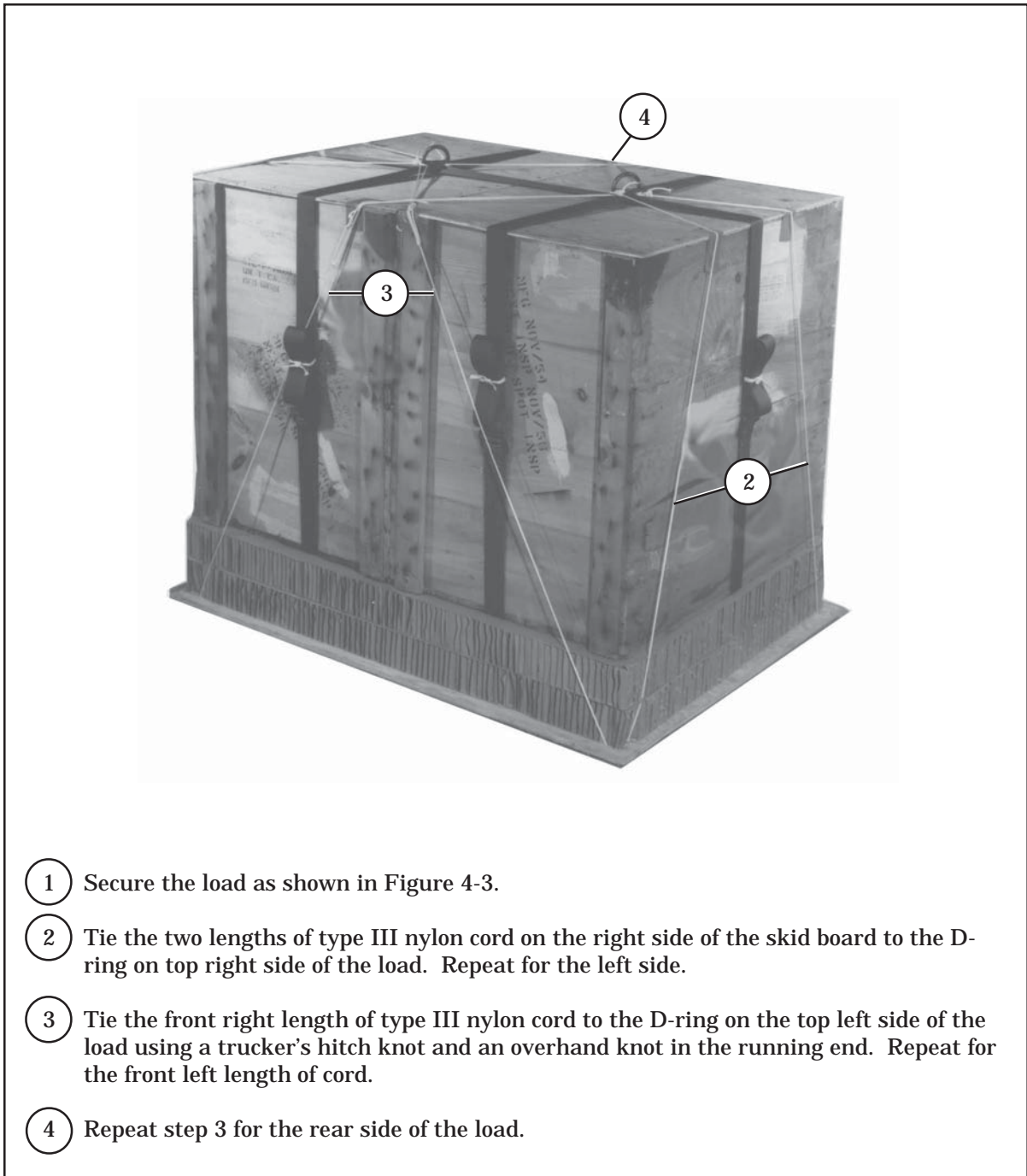


Figure 4-7. Honeycomb Placed and Straps Positioned

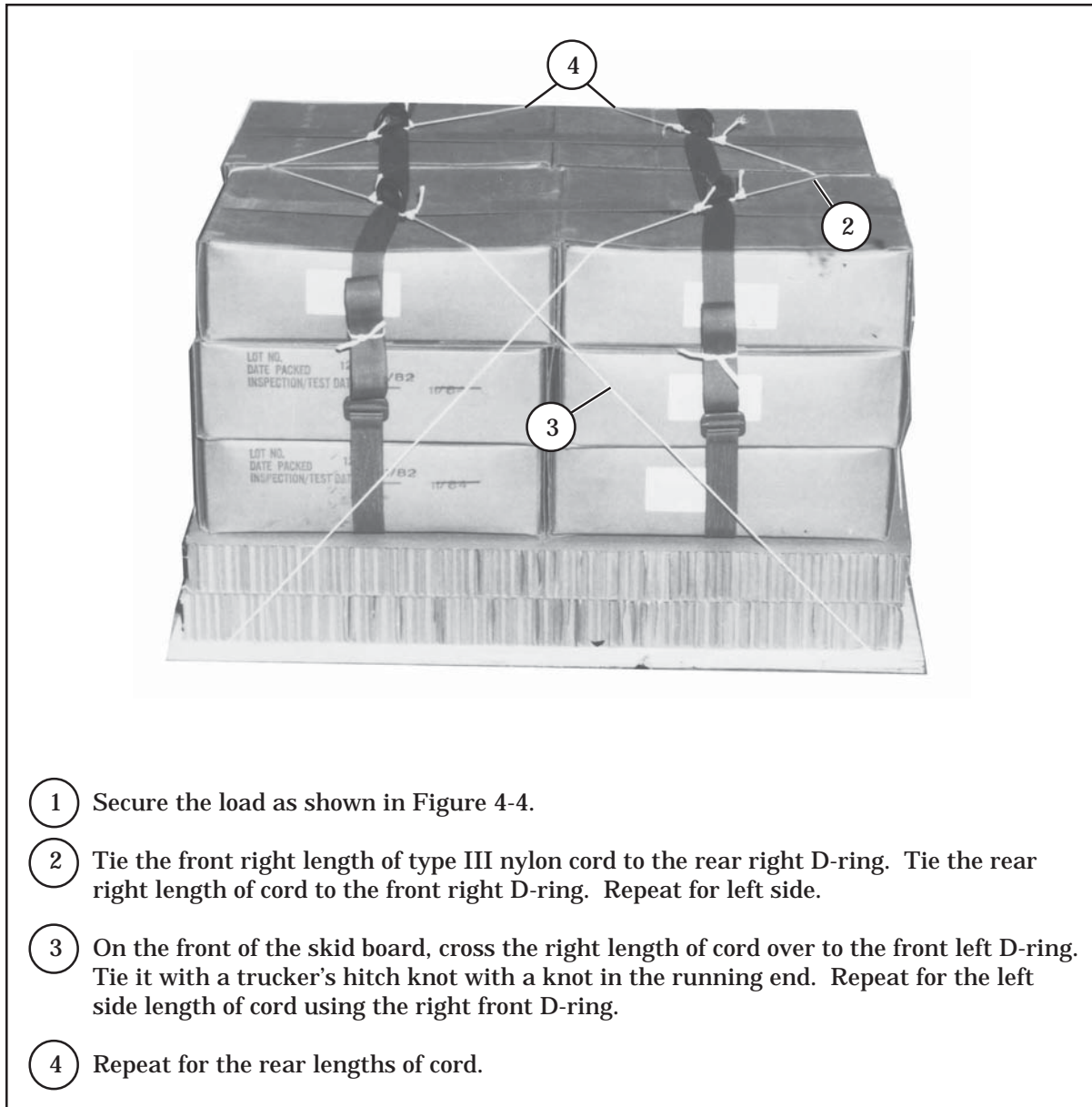


- ① Secure the load as shown in Figure 4-3.
- ② Tie the two lengths of type III nylon cord on the right side of the skid board to the D-ring on top right side of the load. Repeat for the left side.
- ③ Tie the front right length of type III nylon cord to the D-ring on the top left side of the load using a trucker's hitch knot and an overhand knot in the running end. Repeat for the front left length of cord.
- ④ Repeat step 3 for the rear side of the load.

**Figure 4-8. Skid Board Secured To Three-Strap Load**

## INSTALLING PARACHUTE

4-12. Install a T-10 modified cargo or a G-14 cargo parachute on the load according to Chapter 3.



- ① Secure the load as shown in Figure 4-4.
- ② Tie the front right length of type III nylon cord to the rear right D-ring. Tie the rear right length of cord to the front right D-ring. Repeat for left side.
- ③ On the front of the skid board, cross the right length of cord over to the front left D-ring. Tie it with a trucker's hitch knot with a knot in the running end. Repeat for the left side length of cord using the right front D-ring.
- ④ Repeat for the rear lengths of cord.

**Figure 4-9. Skid Board Secured To Four-Strap Load**



## MARKING RIGGED LOAD

4-13. Mark the rigged load according to Paragraph 1-5. Compute the rigged load data.

## EQUIPMENT REQUIRED

4-14. Use the equipment listed in Table 4-2 to rig a four-strap load for low-velocity ramp airdrop as shown in Figure 4-10.

**CAUTION**

Make the final rigger inspection required by FM 4-20.102/NAVSEA SS400-AB-MMO-010/TO 13C7-1-5 and AR 59-4/OPNAVINST 4630.24C/AFJ 13-210(I)/MCO 13480.1B before the load leaves the rigging site.

**RIGGING LOAD DATA**

Weight (without parachute) .....	200 - 500 pounds
Parachute (shown) .....	G-14 cargo

Figure 4-10. Four-Strap A-7A Load Rigged for Low-Velocity Ramp Airdrop

**Table 4-2. Equipment Required for Rigging the Four-Strap A-7A Load for Low-Velocity Ramp Airdrop**

National Stock Number	Item	Quantity
4020-00-240-2146	Cord, nylon, type III	As required
8135-00-664-6958	Cushioning material, packaging, cellulose wadding	As required
1670-00-753-3928	Pad, energy-dissipating material, honeycomb	As required
1670-00-999-2658	Parachute, cargo, G-14	1
5530-00-129-7777	Plywood: 1/2- by 48- by 96-inch or	1 sheet
5530-00-128-4981	3/4- by 48- by 96-inch	1 sheet
1670-00-251-1153	Sling assembly, cargo airdrop, A-7A	1
7510-00-266-6710	Tape, masking, 2-inch	As required
8305-00-268-2411	Webbing: Cotton, 1/4-inch, type I	As required
8305-00-082-5752	Nylon, tubular, 1/2-inch	As required

## SECTION III - HIGH-VELOCITY AIRDROP

### DESCRIPTION OF LOAD

4-15. An A-7A load rigged for high-velocity airdrop is rigged in a similar manner to low-velocity. Three layers of honeycomb and a skid board are required for paratroop door or ramp drop. This load must not exceed 500 pounds, excluding the weight of the parachute.

### PREPARING DROP ITEMS

4-16. Place items in a container so that the A-7A straps can hold the items safely together during exit and descent. Items dropped at high-velocity will impact at a high rate of speed; therefore, sensitive items cannot be dropped using this method.

### PREPARING SKID BOARD

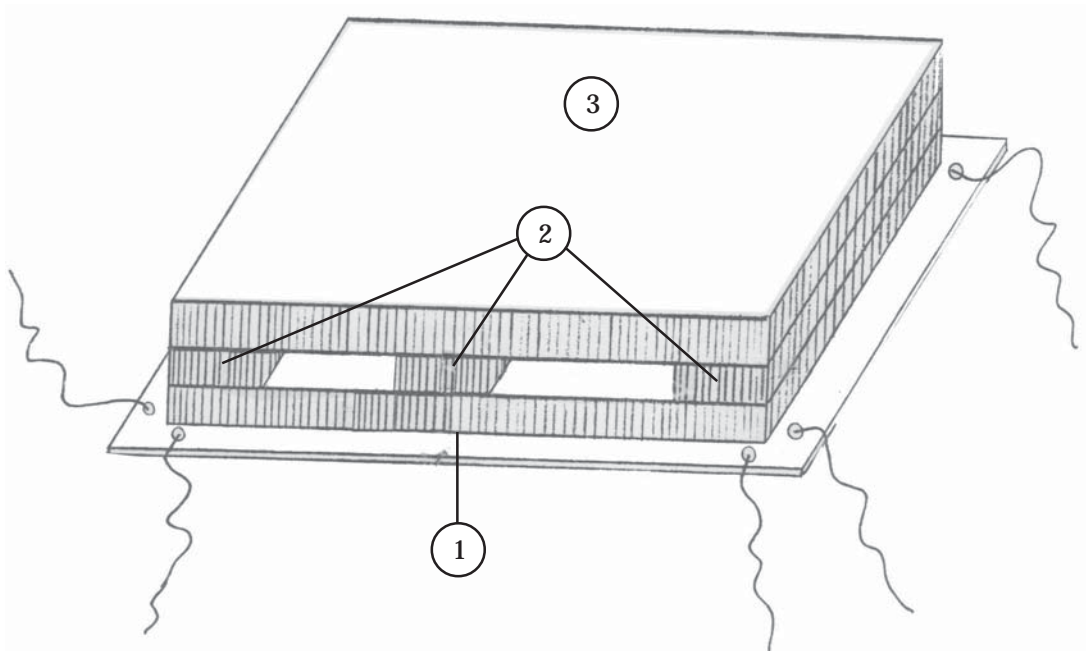
4-17. Prepare the skid board in the same manner as in Section II of this chapter. The skid board will be at least the size of the base of the load for airdrop from the paratroop doors. When the load is being airdropped from the C-130 aircraft's cargo ramp, the skid board will be at least 42 inches wide, but must be 48-inches wide when using the C-17 or C-130 aircraft's CVRS. Route the skid board ties in the same manner as in Section II of this chapter.

## PLACING HONEYCOMB

4-18. Place honeycomb as shown in Figure 4-11.

### NOTES:

1. This drawing is not drawn to scale.
2. All dimensions are given in inches.



- 1 Cut one piece of honeycomb at least the size of the base of the load and center it on the load.
- 2 Cut three pieces of honeycomb 3 inches wide and the length of the honeycomb cut in step 1. Glue one piece centered on top of the first layer of honeycomb. Glue the other pieces of honeycomb flush with each side edge.
- 3 Cut and glue another piece of honeycomb the same size as in step 1 and place it on top of the second layer of honeycomb.

Figure 4-11. Honeycomb Placed

## SECURING STRAPS

4-19. Secure the straps according to Section I of this chapter.

## SECURING SKID BOARD

4-20. Secure the skid board to the load as shown in Section II of this chapter.

## INSTALLING PARACHUTE

4-21. Install the parachute on the load according to Chapter 3.

## MARKING RIGGED LOAD

4-22. Mark the rigged load according to Paragraph 1-5. Compute the rigged load data.

## EQUIPMENT REQUIRED

4-23. Use the equipment listed in Table 4-3 to rig a four strap load for high-velocity airdrop as shown in Figure 4-12.

**Table 4-3. Equipment Required for Rigging the Four-Strap A-7A Load for High-Velocity Ramp Airdrop**

National Stock Number	Item	Quantity
8040-00-273-8713	Adhesive, paste, 1-gallon	As required
4020-00-240-2146	Cord, nylon, type III	As required
8135-00-664-6958	Cushioning material, packaging, cellulose wadding	As required
1670-00-753-3928	Pad, energy-dissipating material, honeycomb	As required
1670-00-788-8666	Parachute, cargo, high-velocity, 12-foot	1
5530-00-129-7777	Plywood: 1/2- by 48- by 96-inch	1 sheet
5530-00-128-4981	or 3/4- by 48- by 96-inch	1 sheet
1670-00-251-1153	Sling assembly, cargo airdrop, A-7A	1
7510-00-266-6710	Tape, masking, 2-inch	As required
8305-00-268-2411	Webbing: Cotton, 1/4-inch, type I	As required
8305-00-082-5752	Nylon, tubular, 1/2-inch	As required

**CAUTION**

Make the final rigger inspection required by FM 4-20.102/NAVSEA SS400-AB-MMO-010/TO 13C7-1-5 and AR 59-4/OPNAVINST 4630.24C/AFJ 13-210(I)/MCO 13480.1B before the load leaves the rigging site.



**RIGGING LOAD DATA (without parachute)**

- \* One 68-inch parachute ..... 75 - 150 pounds
- Three 68-inch parachutes ..... 151 - 500 pounds
- \* One 12-foot, high-velocity cargo parachute (shown) ..... 151 - 500 pounds
- One 15-foot (modified for high velocity) ..... 151 - 500 pounds
  
- \* Primary parachute

**Figure 4-12. Four-Strap A-7A Load Rigged for High-Velocity Ramp Airdrop**

**This page intentionally left blank.**

PART THREE

RIGGING A-21 CONTAINER LOADS

Chapter 5

General Information and Procedures

A-21 CARGO BAG ASSEMBLY

5-1. The A-21 cargo bag assembly is an adjustable airdrop container. It consists of a sling assembly and a 97- by 115-inch canvas cover. The sling assembly consists of the sling portion with a scuff pad attached, two O-ring straps, three quick-release straps, and one quick-release strap with a quick-release assembly attached. Figure 5-1 shows an A-21 cargo bag assembly.

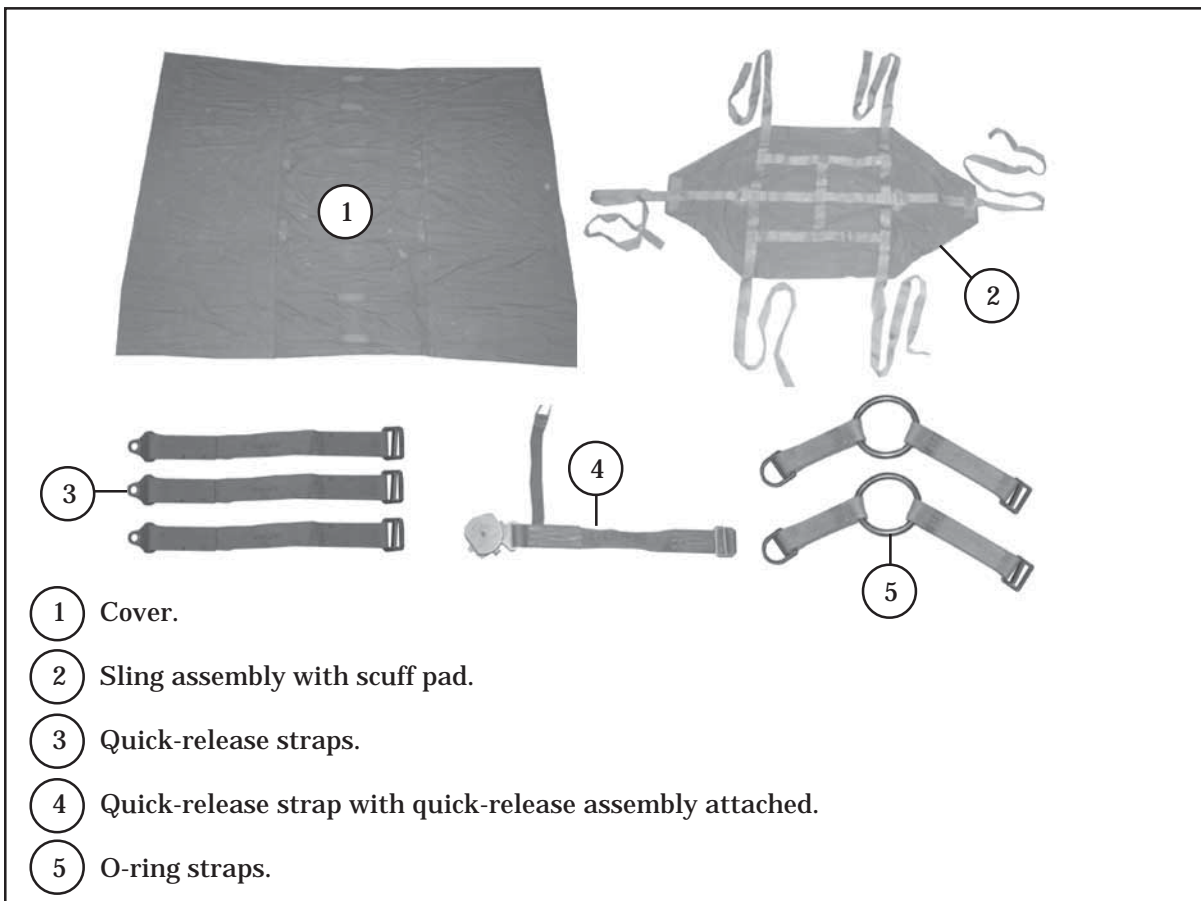


Figure 5-1. A-21 Cargo Bag Assembly

## CAPABILITIES OF A-21 CARGO BAG

5-2. The A-21 cargo bag can exit either through paratroop doors or off the ramp. The container can be rigged for low-velocity or high-velocity airdrop. The container is capable of dropping loads up to 500 pounds of rigged weight, excluding the weight of the parachute. When dropped from the paratroop doors, the load must weigh a minimum of 11 pounds per square foot. When dropped from the ramp, the load must weigh a minimum of 28 pounds per square foot. Table 5-1 lists parachutes used with this container and the weight restrictions.

## PARACHUTES USED FOR A-21 CARGO BAG

5-3. The T-10 modified cargo or G-14 cargo parachute is the parachute used on this container for low-velocity drops. For high-velocity drops, the primary parachute is a 12-foot, high-velocity cargo parachute. If a 12-foot, high-velocity cargo parachute is not available, a 15-foot cargo extraction parachute or three 68-inch pilot parachutes may be used. Table 5-1 gives the weight ranges.

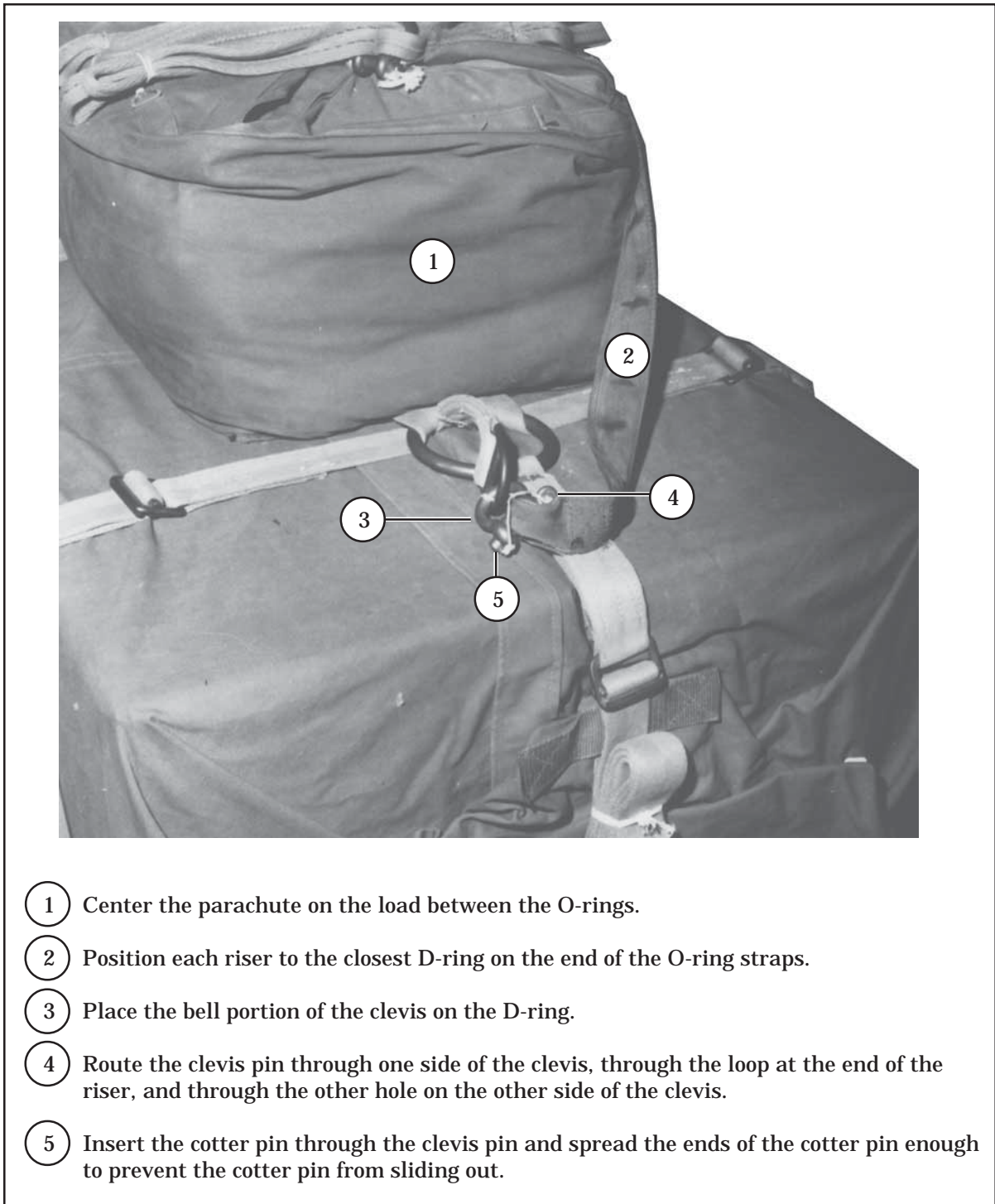
Table 5-1. Parachute Requirements for A-21 Cargo Bag

Parachute	Suspended Weight (Pounds)	
	Minimum	Maximum
Low-Velocity		
One T-10 modified cargo	90	500
One G-14 cargo	200	500
High-Velocity		
Three 68-inch pilot	151	500
*One 12-foot high-velocity	151	500
One 15-foot cargo extraction	151	500
* Primary parachute		

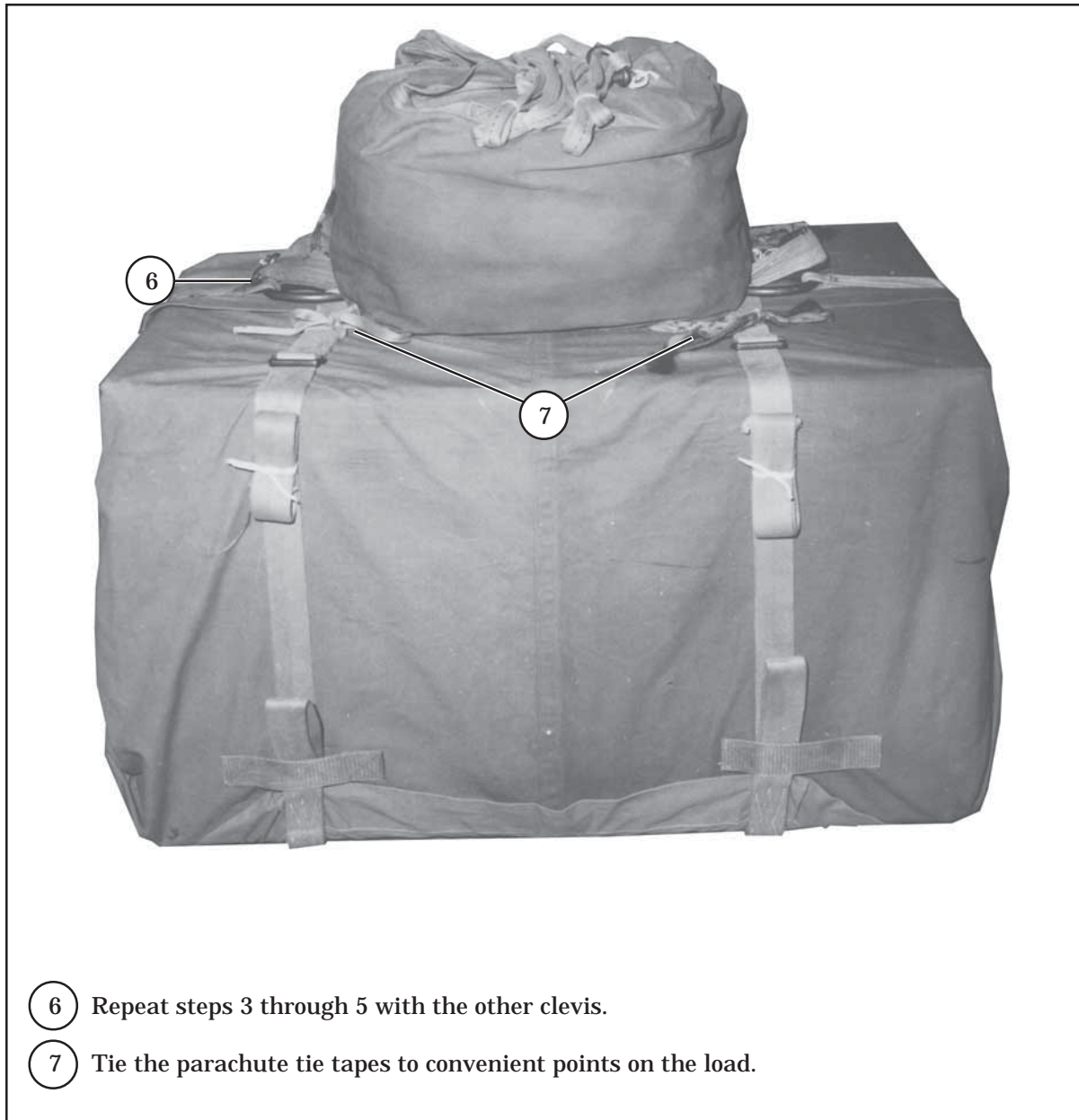
## INSTALLING PARACHUTE ON A-21 CARGO BAGS

5-4. The parachutes used on A-21 loads are installed to the two D-rings located on the O-ring straps. Figure 5-2 shows how to install the G-14 cargo parachute. Steps similar to the G-14 cargo parachute installation are used when installing the T-10 modified cargo parachute. Figure 5-3 shows how to install the 12-foot, high-velocity cargo parachute. When using the 68-inch pilot parachute or 15-foot cargo extraction parachute, refer to Chapter 3 and modify the procedures to the two D-rings on the O-ring straps.

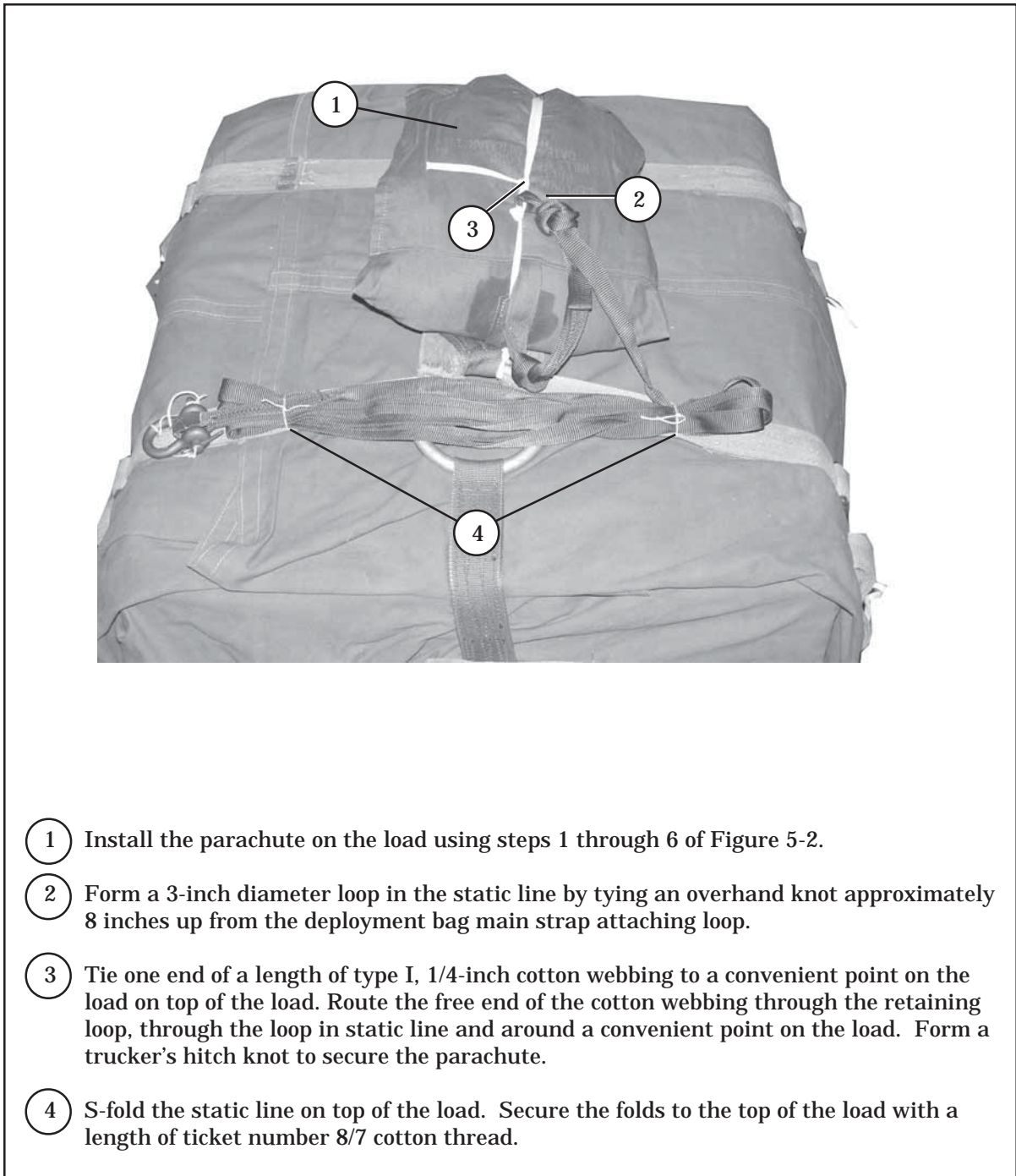




**Figure 5-2. G-14 Cargo Parachute Installed**



**Figure 5-2. G-14 Cargo Parachute Installed (Continued)**



**Figure 5-3. 12-Foot, High-Velocity Cargo Parachute Installed**

**This page intentionally left blank.**

## Chapter 6

# Rigging Typical A-21 Loads

### SECTION I - LOW-VELOCITY AIRDROP FROM PARATROOP DOOR

#### DESCRIPTION OF LOAD

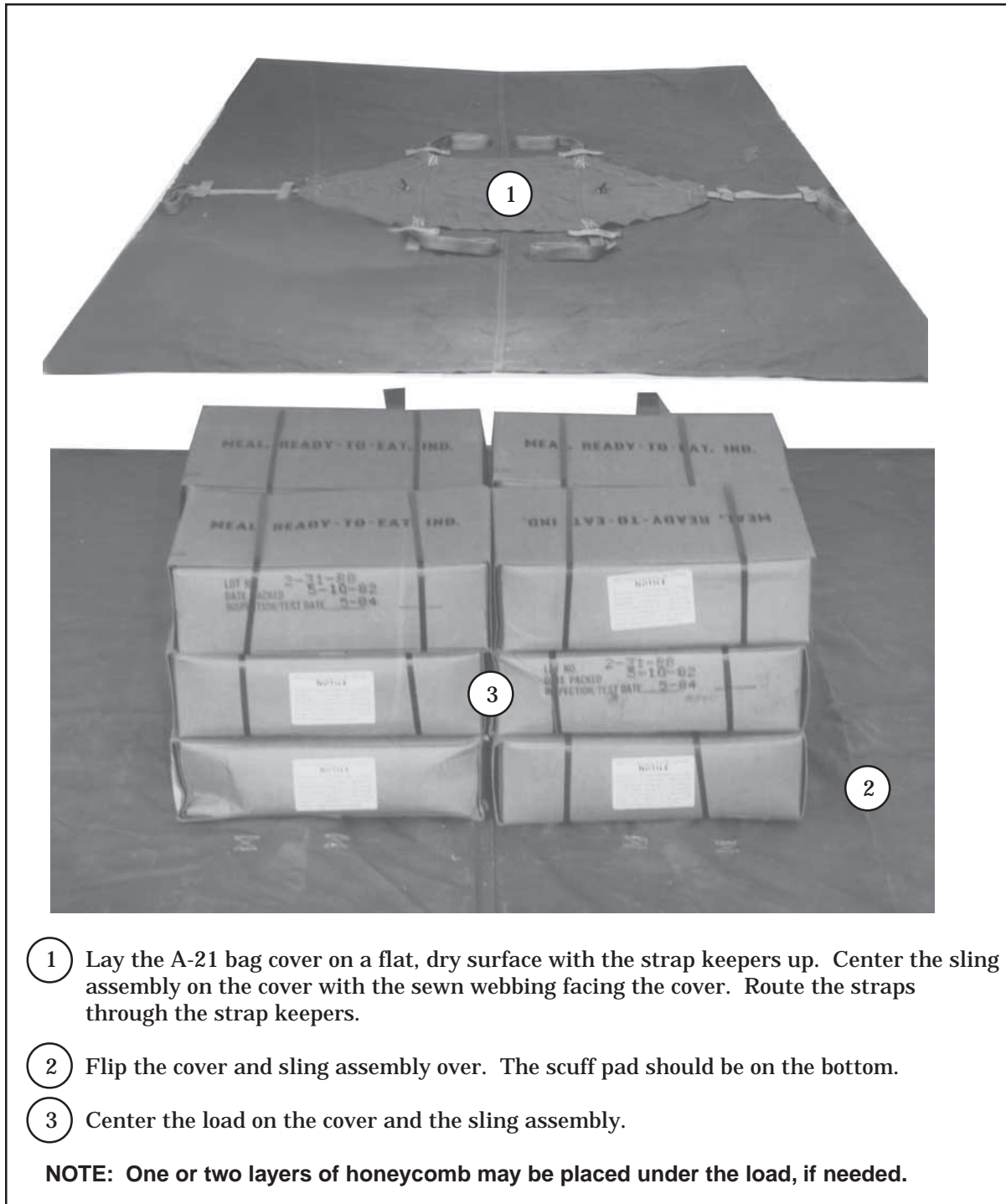
6-1. Typical A-21 loads are rigged for airdrop from a paratroop door of an aircraft. Typical loads include rations, repair parts, water cans, and other small nonfragile items. Items to be dropped may be rigged in their original container or may be repacked and padded further to prevent damage. When completely rigged, the load must not exceed 500 pounds, excluding the weight of the parachute. The maximum dimensions for this load are 48- by 30- by 66-inches. Refer to Part Two for general rigging information and aircraft considerations and restrictions.

#### PREPARING DROP ITEMS

6-2. Prepare the drop items according to the load's sensitivity. Some items will require no padding while others will need padding with cellulose wadding, felt, and honeycomb. All items should be padded well to prevent damage during airdrop. In addition, items must be in containers large enough so they will not fall out of the load during airdrop.

#### POSITIONING CONTAINER AND LOAD

6-3. Position the container and load as shown in Figure 6-1.



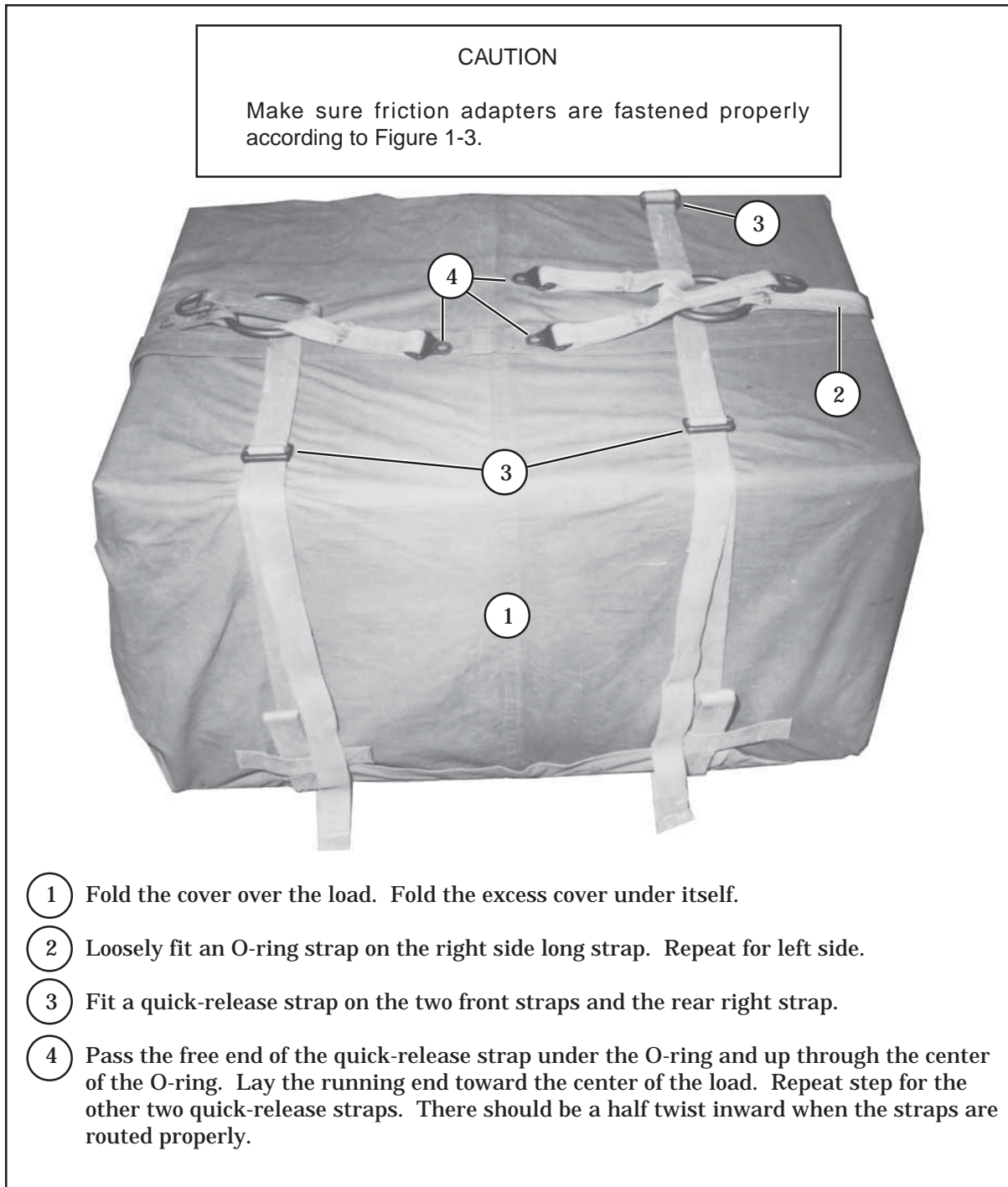
- ① Lay the A-21 bag cover on a flat, dry surface with the strap keepers up. Center the sling assembly on the cover with the sewn webbing facing the cover. Route the straps through the strap keepers.
- ② Flip the cover and sling assembly over. The scuff pad should be on the bottom.
- ③ Center the load on the cover and the sling assembly.

**NOTE:** One or two layers of honeycomb may be placed under the load, if needed.

**Figure 6-1. Container and Load Positioned**

## RIGGING CONTAINER

6-4. Rig the container as shown in Figure 6-2.



**Figure 6-2. Container Rigged**



Figure 6-2. Container Rigged (Continued)



## INSTALLING PARACHUTE

6-5. Install the T-10 modified cargo or the G-14 cargo parachute according to Paragraph 5-4.

## MARKING RIGGED LOAD


6-6. Mark the rigged load according to Paragraph 1-5. Compute the rigged load data.

## EQUIPMENT REQUIRED

6-7. Use the equipment listed in Table 6-1 to rig the load as shown in Figure 6-3.

**CAUTION**

Make the final rigger inspection required by FM 4-20.102/NAVSEA SS400-AB-MMO-010/TO 13C7-1-5 and AR 59-4/OPNAVINST 4630.24C/AFJ 13-210(I)/MCO 13480.1B before the load leaves the rigging site.



**RIGGING LOAD DATA (without parachute)**

G-14 cargo parachute (shown) .....	200 - 500 pounds
T-10 modified cargo parachute .....	200 - 500 pounds

Figure 6-3. A-21 Container Load Rigged for Low-Velocity Paratroop Door Airdrop

**Table 6-1. Equipment Required for Rigging the A-21 Container Load  
For Low-Velocity Paratroop Door Airdrop**

National Stock Number	Item	Quantity
1670-00-242-9173	Bag, cargo, A-21	1
8135-00-664-6958	Cushioning material, packaging, cellulose wadding	As required
1670-00-753-3928	Pad, energy-dissipating material, honeycomb	As required
1670-00-999-2658	Parachute, cargo, G-14	1
8305-00-268-2411	Cotton, 1/4-inch, type I	As required

## SECTION II - LOW-VELOCITY AIRDROP FROM RAMP

### DESCRIPTION OF LOAD

6-8. Typical A-21 loads are rigged to be dropped off the ramp of an aircraft. Typical loads include rations, water cans, small parts, and other nonfragile supplies. The load must be rigged with a skid board. The weight range for an A-21 load is 200 to 500 pounds, excluding the weight of the parachute.

### PREPARING DROP ITEMS

6-9. Prepare the drop items according to the load's sensitivity. Some items will require no padding while others will require cellulose wadding, felt, and honeycomb. All items should be padded well to prevent damage during airdrop.

### PREPARING SKID BOARD

6-10. Prepare a skid board as shown in Figure 6-4.

### POSITIONING CONTAINER AND LOAD

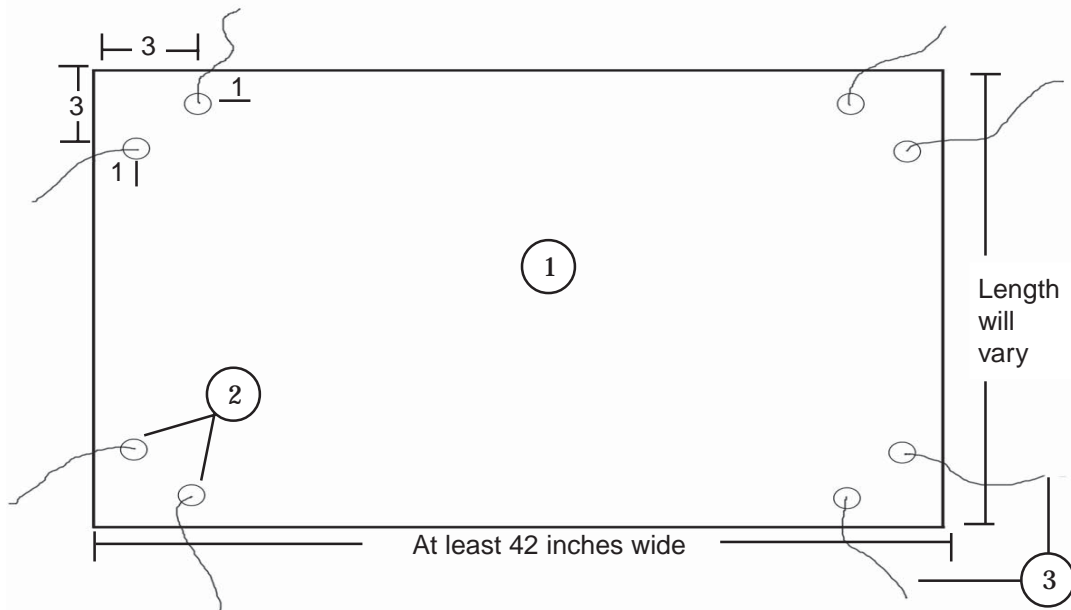
6-11. Position the container and load according to Paragraph 6-3.

### RIGGING CONTAINER

6-12. Rig the container according to Paragraph 6-4.

**NOTES:**

1. This drawing is not drawn to scale.
2. All dimensions are given in inches.



- 1 Place a 1/2- or 3/4-inch piece of plywood on a flat surface. Size will vary depending on load.
- 2 Drill eight 1/2-inch holes as shown above.
- 3 Pass a length of type III nylon cord through each set of holes. The length of the cord will vary according to the height of the load. If the type III nylon cord is not available, use 1/2-inch tubular nylon webbing.
- 4 If required, place two layers of honeycomb the size of the base of the load on the skid board (not shown).

**Figure 6-4. Skid Board Prepared**

## SECURING SKID BOARD

6-13. Secure the skid board to the load as shown in Figure 6-5.

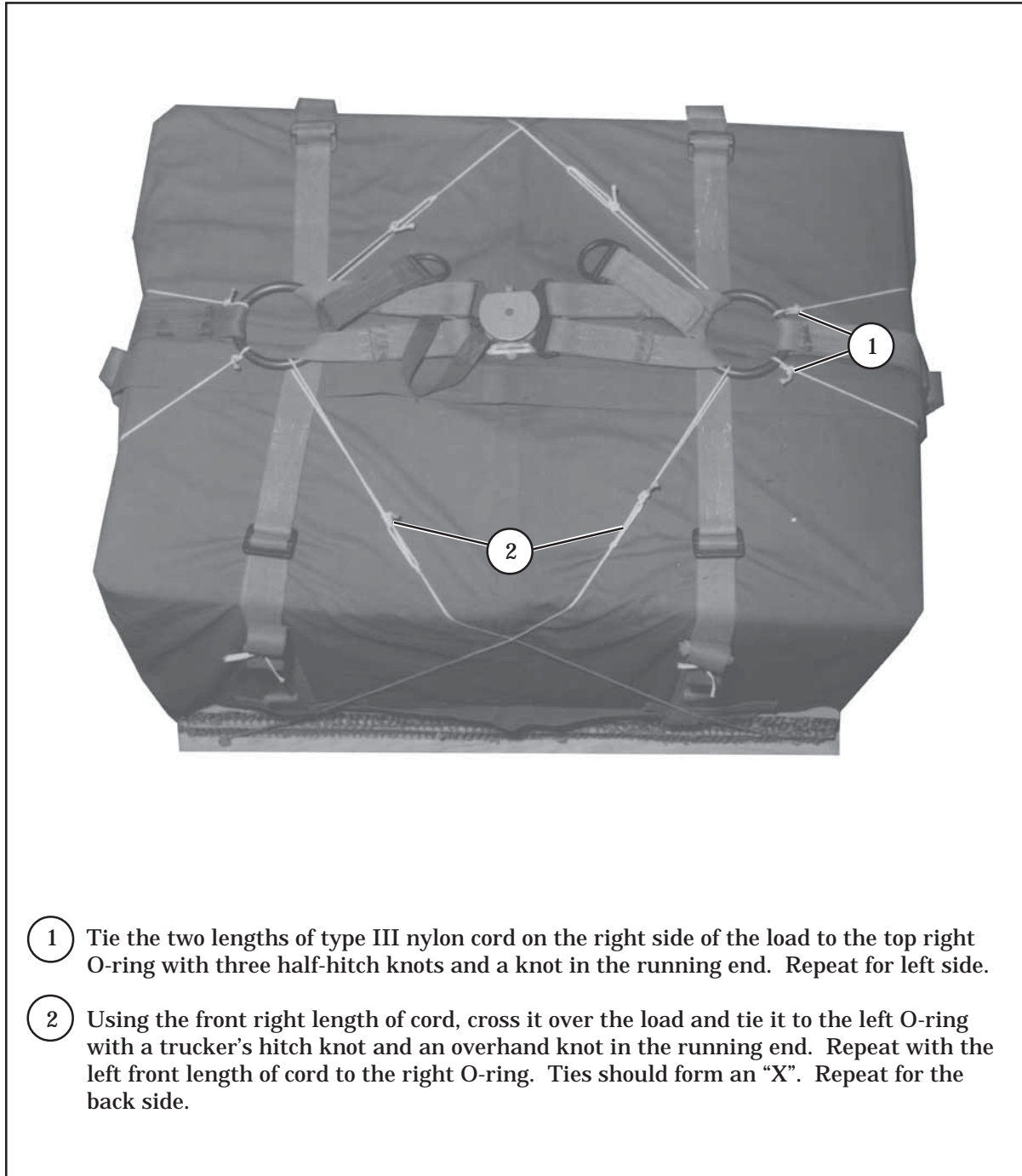


Figure 6-5. Skid Board Secured

## INSTALLING PARACHUTE

6-14. Install the T-10 modified cargo or the G-14 cargo parachute to the load according to Paragraph 5-4.

## MARKING RIGGED LOAD


6-15. Mark the rigged load according to Paragraph 1-5. Compute the rigged load data.

## EQUIPMENT REQUIRED

6-16. Use the equipment listed in Table 6-2 to rig the load shown in Figure 6-6.

**CAUTION**

Make the final rigger inspection required by FM 4-20.102/NAVSEA SS400-AB-MMO-010/TO 13C7-1-5 and AR 59-4/OPNAVINST 4630.24C/AFJ 13-210(I)/MCO 13480.1B before the load leaves the rigging site.



**RIGGING LOAD DATA (without parachute)**

G-14 cargo parachute (shown) .....	200 - 500 pounds
T-10 modified cargo parachute .....	200 - 500 pounds

Figure 6-6. A-21 Container Load Rigged for Low-Velocity Ramp Airdrop

**Table 6-2. Equipment Required for Rigging the A-21 Container Load for Low-Velocity Ramp Airdrop**

National Stock Number	Item	Quantity
1670-00-242-9173	Bag, cargo, A-21	1
4020-00-240-2146	Cord, nylon, type III	As required
8135-00-664-6958	Cushioning material, packaging, cellulose wadding	As required
1670-00-753-3928	Pad, energy-dissipating material, honeycomb	As required
1670-00-999-2658	Parachute, cargo, G-14	1
5530-00-129-7777	Plywood: 1/2- by 48- by 96-inch or	1 sheet
5530-00-128-4981	3/4- by 48- by 96-inch	1 sheet
8305-00-268-2411	Webbing, cotton, 1/4-inch, type I	As required

**SECTION III - HIGH-VELOCITY AIRDROP**

**DESCRIPTION OF LOAD**

6-17. Typical A-21 loads are rigged for high-velocity airdrop from either the paratroop door or ramp of an aircraft. Typical loads include rations, water cans, small repair parts, and other small nonfragile items. The load shown in this section consists of rations and boxes filled with sand to increase weight. The load cannot exceed 500 pounds, excluding the weight of the parachute. The minimum weight will vary according to the parachute used. The load shown in this section is rigged with one 12-foot, high-velocity cargo parachute.

**PREPARING DROP ITEMS**

6-18. Prepare the drop items according to the load's sensitivity. Items should be well padded so items will not be damaged during airdrop. Items can be dropped in original container or repacked if necessary.

## PREPARING SKID BOARD

6-19. Prepare a skid board for ramp drop as shown in Figure 6-4. For paratroop door drops, the skid board is optional. When the load is being airdropped from the C-130 aircraft's cargo ramp, the skid board will be at least 42 inches wide, but must be 48-inches wide when using the C-17 or C-130 aircraft's CVRS.

## POSITIONING HONEYCOMB

6-20. Use honeycomb on paratroop door or ramp drops. When the skid board is not used, place the honeycomb inside the container when rigging the load. When the skid board is used, place honeycomb inside or outside the container. Prepare and position the honeycomb as shown in Figure 6-7.

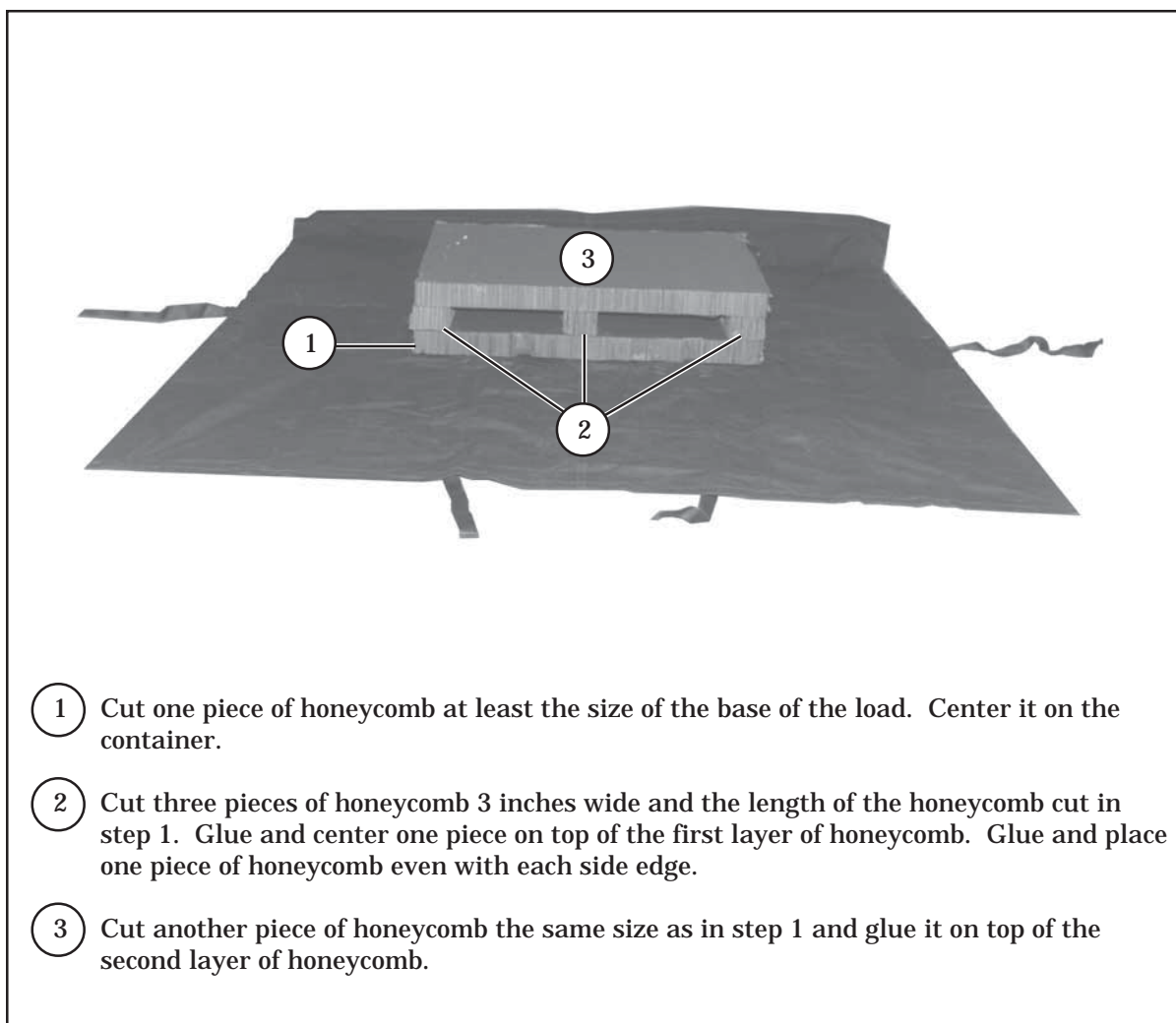


Figure 6-7. A-21 Honeycomb Prepared and Positioned

**POSITIONING CONTAINER AND LOAD**

6-21. Position the container and load according to Paragraph 6-3.

**RIGGING CONTAINER**

6-22. Rig the container according to Paragraph 6-4.

**SECURING SKID BOARD**

6-23. Secure the skid board according to Paragraph 6-13.

**INSTALLING PARACHUTE**

6-24. Install the parachute according to Chapters 3 and 5.

**MARKING RIGGED LOAD**

6-25. Mark the rigged load according to Paragraph 1-5. Compute the rigged load data.

**EQUIPMENT REQUIRED**

6-26. Use the equipment listed in Table 6-3 to rig the load shown in Figure 6-8.

**Table 6-3. Equipment Required for Rigging A-21 Container Load for High-Velocity Airdrop**

National Stock Number	Item	Quantity
8040-00-273-8713	Adhesive, paste, 1-gallon	As required
1670-00-242-9173	Bag, cargo, A-21	1
4020-00-240-2146	Cord, nylon, type III	As required
8135-00-664-6958	Cushioning material, packaging, cellulose wadding	As required
1670-00-753-3928	Pad, energy-dissipating material, honeycomb	As required
1670-00-999-2658	Parachute, cargo, G-14	1
5530-00-129-7777	Plywood: 1/2- by 48- by 96-inch or	1 sheet
5530-00-128-4981	3/4- by 48- by 96-inch	1 sheet
7510-00-266-6710	Tape, masking, 2-inch	As required
8305-00-268-2411	Webbing: Cotton, 1/4-inch, type I	As required
8305-00-082-5752	Nylon, tubular, 1/2-inch	As required



**CAUTION**

Make the final rigger inspection required by FM 4-20.102/ NAVSEA SS400-AB-MMO-010/TO 13C7-1-5 and AR 59-4/OPNAVINST 4630.24C/AFJ 13-210(I)/MCO 13480.1B before the load leaves the rigging site.



**RIGGING LOAD DATA (without parachute)**

Three 68-inch parachutes .....	151 - 500 pounds
*12-foot, high-velocity cargo parachute (shown) .....	151 - 500 pounds
15-foot modified parachute for high-velocity .....	151 - 500 pounds

\*Primary parachute

**Figure 6-8. A-21 Container Load Rigged For High-Velocity Airdrop**

**This page intentionally left blank.**

## Chapter 7

# Rigging Ground Laser Location Designator in A-21 Container Rigged for Low-Velocity Airdrop

### DESCRIPTION OF LOAD

7-1. The ground laser location designator (GLLD) is rigged in an A-21 cargo bag with one G-14 cargo parachute. Three A-7A straps are also needed to secure equipment within the container to the skid board. The GLLD components are the tripod, night vision sight and battery, laser designator in a backpack, batteries traversing unit and batteries, vehicle power conditioner, cables, and collimator. Four cases of rations are dropped with the GLLD.

### PREPARING SKID BOARDS

7-2. Prepare two skid boards as shown in Figure 7-1.

### PLACING HONEYCOMB AND TOP SKID BOARD

7-3. Place honeycomb and top skid board as shown in Figure 7-2.

### RIGGING GLLD

7-4. Rig the GLLD according to Figure 7-3.

### INSTALLING PARACHUTE

7-5. Install the G-14 cargo parachute according to Chapter 5.

### MARKING RIGGED LOAD

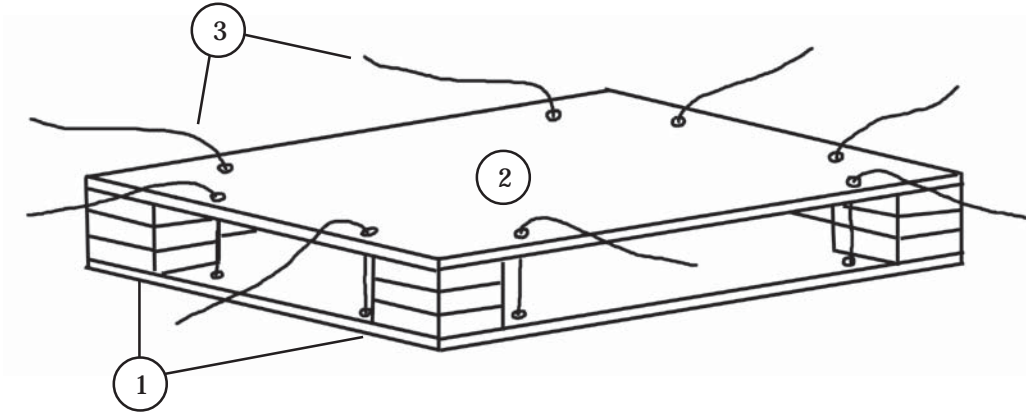
7-6. Mark the rigged load according to Paragraph 1-5 using the data given in Figure 7-4. If the load varies from the one shown in Figure 7-4, recompute the rigged load data.

### EQUIPMENT REQUIRED

7-7. Use the equipment listed in Table 7-1 to rig the load shown in Figure 7-4.



**NOTE:** This drawing is not drawn to scale.



- ① Cut twelve 8- by 8-inch pieces of honeycomb. Place the honeycomb in four stacks (three pieces each). Glue each stack together. Place a stack flush in each corner of the skid board. Glue the stacks to the skid board.
- ② Center the top skid board (prepared in Figure 7-1) on top of the honeycomb.
- ③ Route the lengths of webbing (Figure 7-1, step 3) through the top skid board as shown above.

**Figure 7-2. Honeycomb and Top Skid Boards Placed**

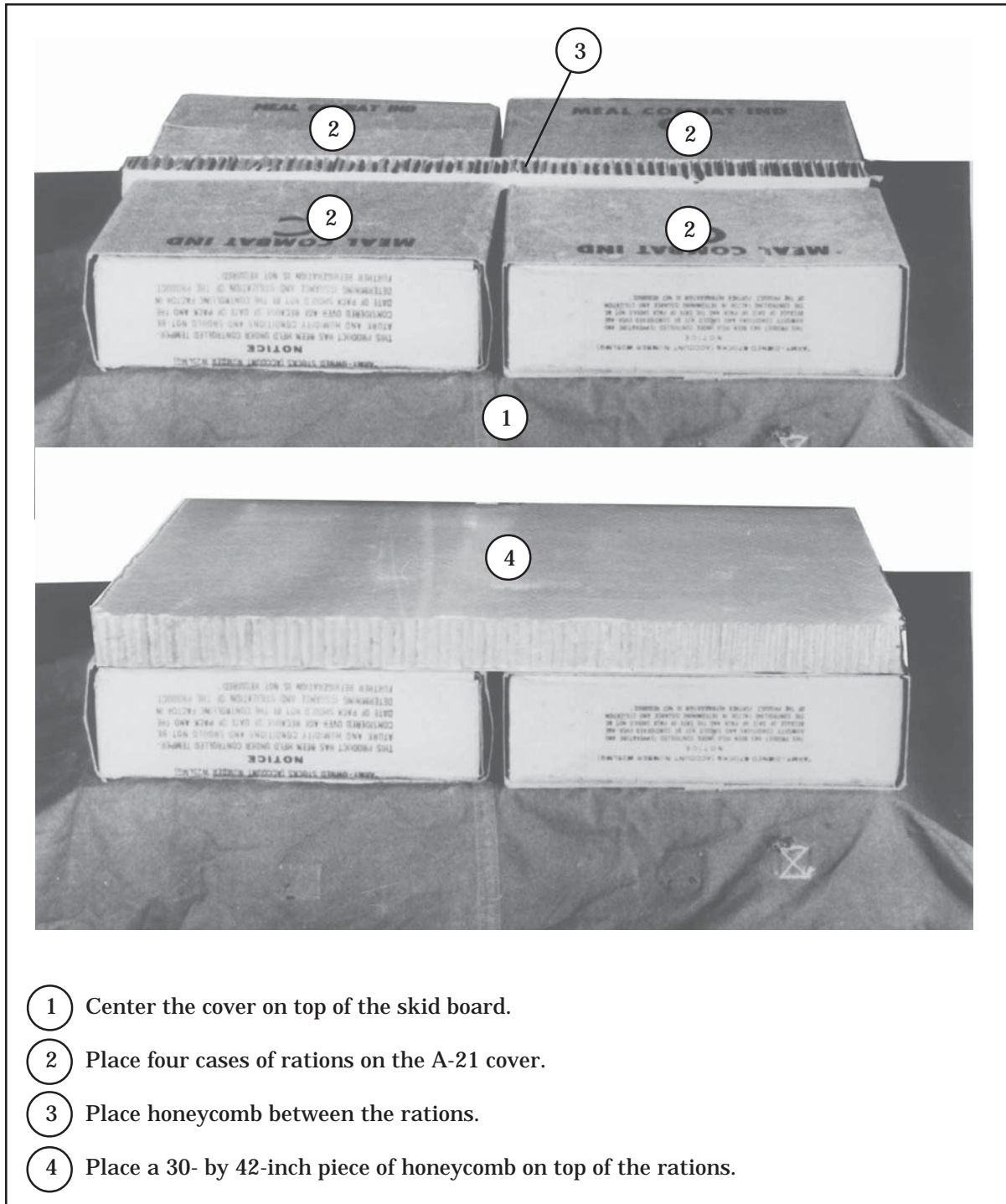


Figure 7-3. GLLD Rigged

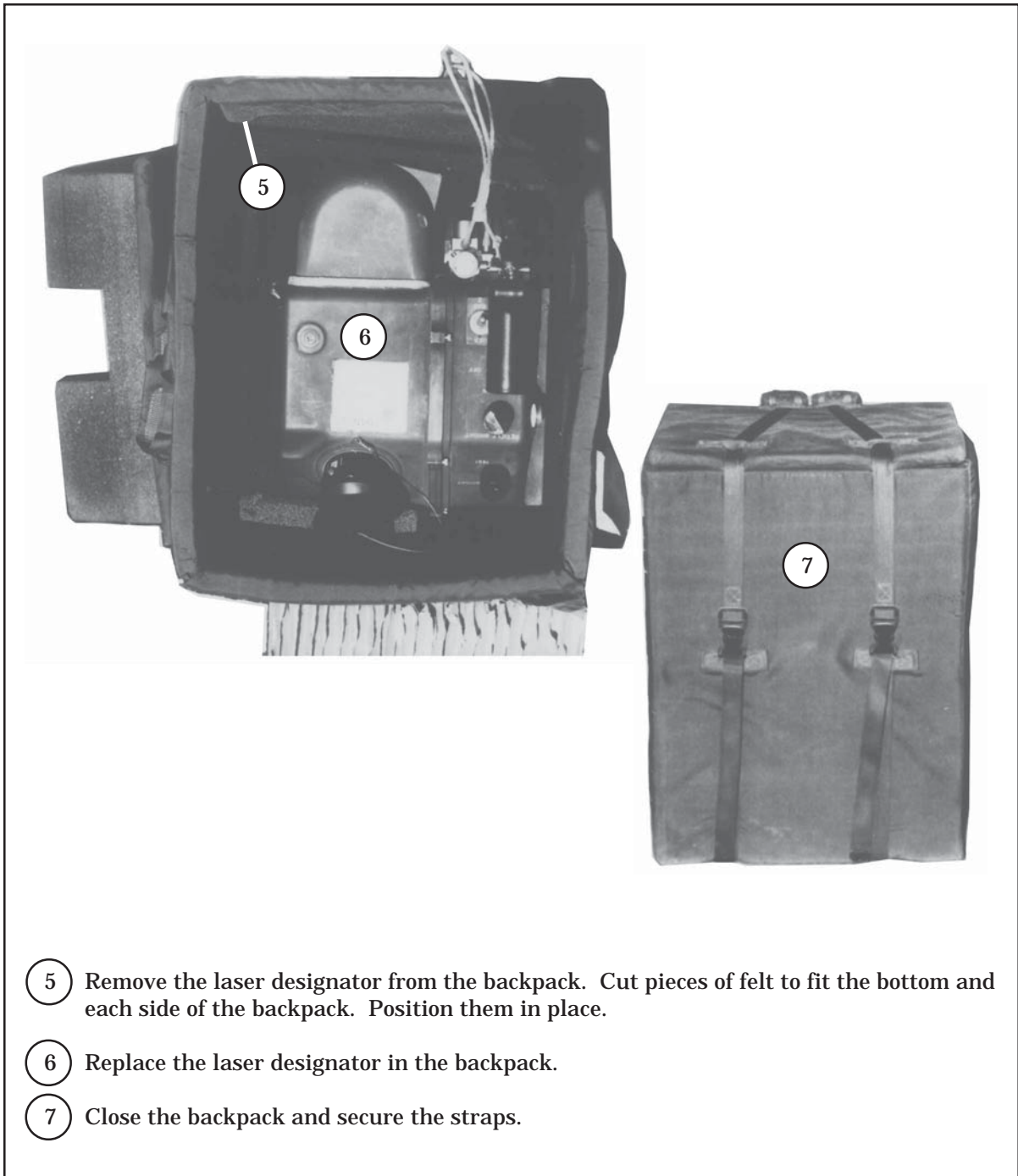
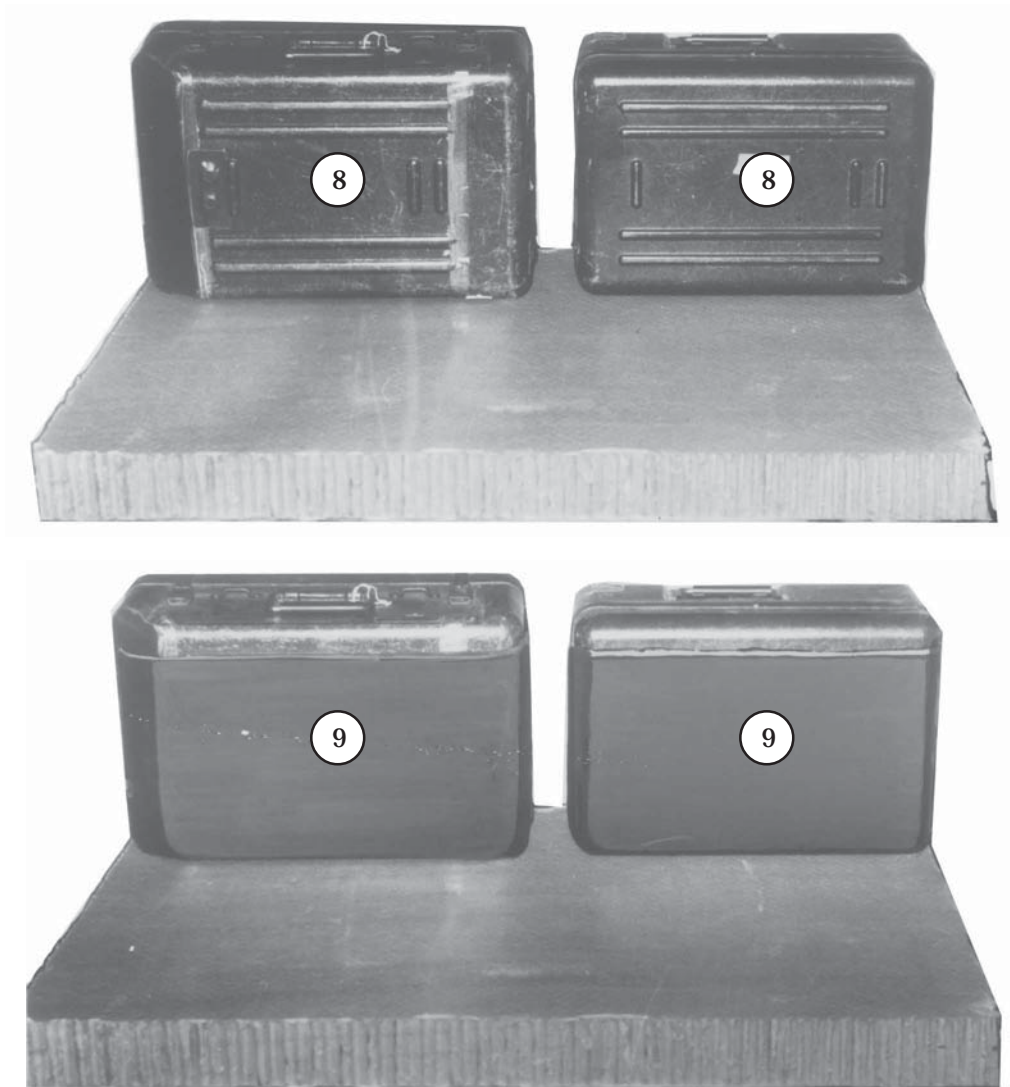


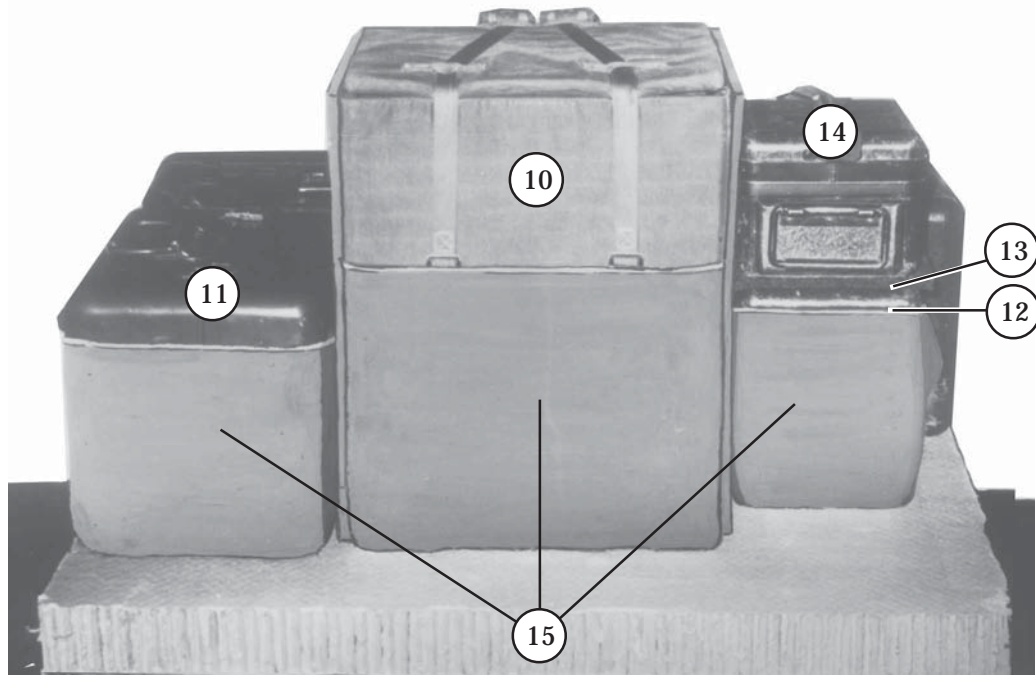
Figure 7-3. GLLD Rigged (Continued)



- ⑧ Place the collimator and the night sight at the rear of the 30- by 42-inch piece of honeycomb.
- ⑨ Pad the collimator and the night sight with felt.

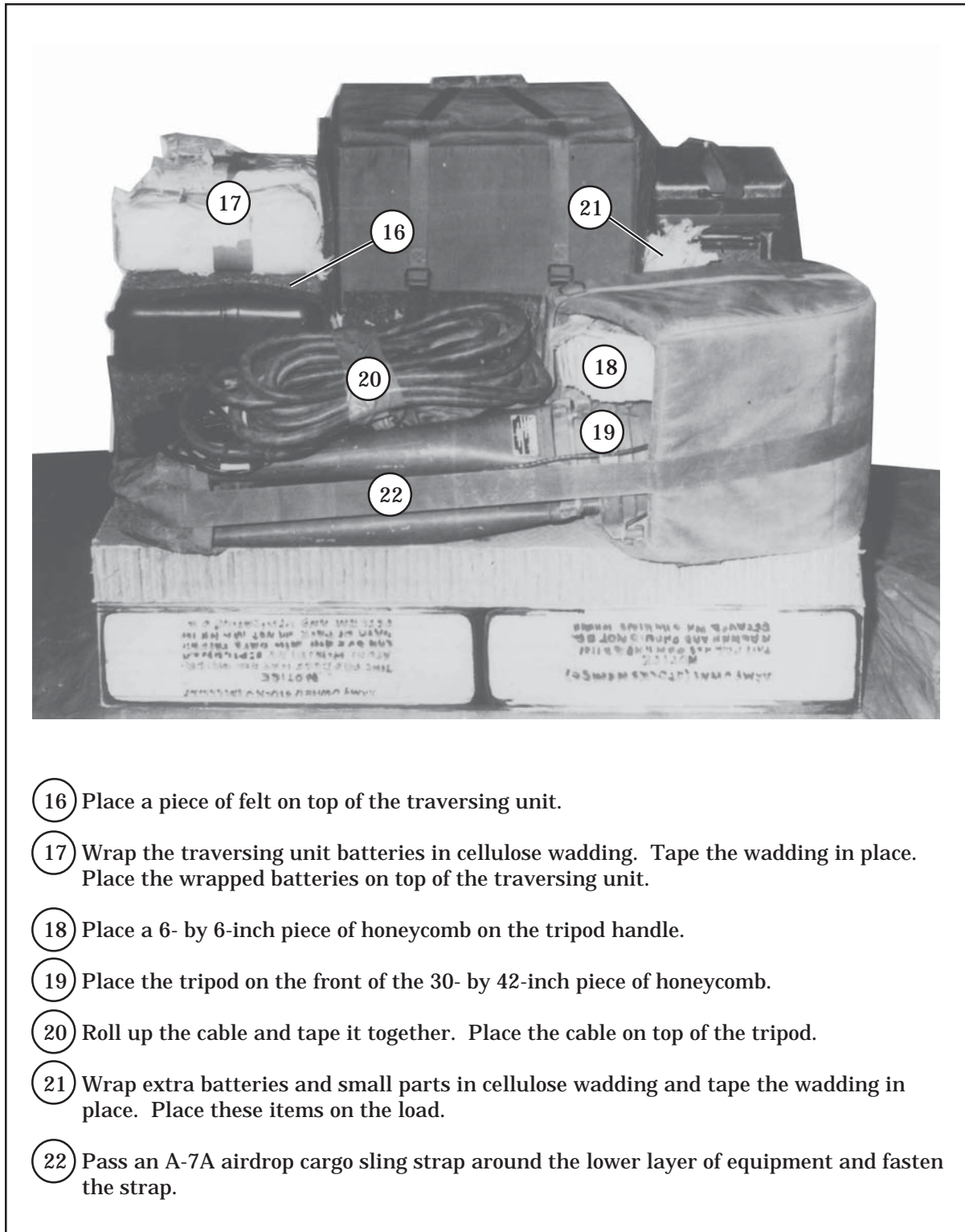
Figure 7-3. GLLD Rigged (Continued)





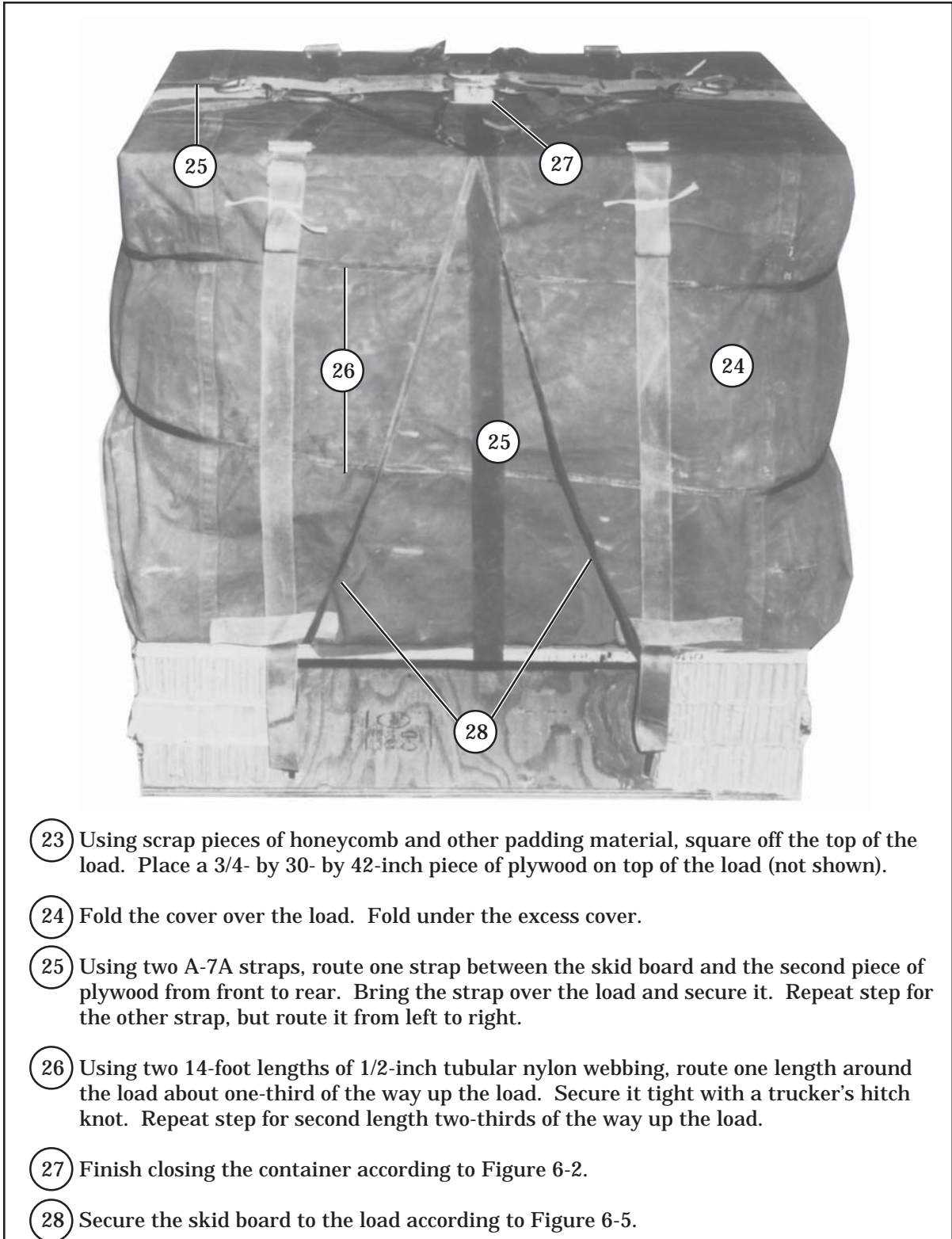
- ⑩ Place the laser designator near the center of the 30- by 42-inch piece of honeycomb.
- ⑪ Place the traversing unit on the honeycomb to the left of the laser designator.
- ⑫ Place the vehicle power conditioner on the honeycomb to the right of the laser designator.
- ⑬ Cut and position a piece of felt to fit the top of the power conditioner.
- ⑭ Place the night vision sight batteries on top of the power conditioner.
- ⑮ Pad the laser designator, the traversing unit, and the vehicle power conditioner with pieces of felt.

**Figure 7-3. GLLD Rigged (Continued)**



- ①⑥ Place a piece of felt on top of the traversing unit.
- ①⑦ Wrap the traversing unit batteries in cellulose wadding. Tape the wadding in place. Place the wrapped batteries on top of the traversing unit.
- ①⑧ Place a 6- by 6-inch piece of honeycomb on the tripod handle.
- ①⑨ Place the tripod on the front of the 30- by 42-inch piece of honeycomb.
- ②⑦ Roll up the cable and tape it together. Place the cable on top of the tripod.
- ②① Wrap extra batteries and small parts in cellulose wadding and tape the wadding in place. Place these items on the load.
- ②② Pass an A-7A airdrop cargo sling strap around the lower layer of equipment and fasten the strap.

Figure 7-3. GLLD Rigged (Continued)

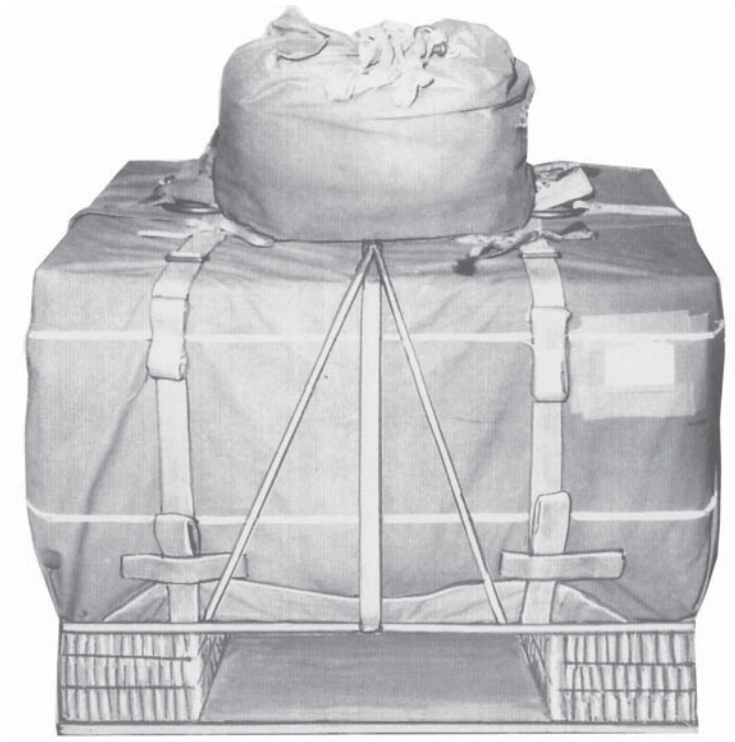


- 23 Using scrap pieces of honeycomb and other padding material, square off the top of the load. Place a 3/4- by 30- by 42-inch piece of plywood on top of the load (not shown).
- 24 Fold the cover over the load. Fold under the excess cover.
- 25 Using two A-7A straps, route one strap between the skid board and the second piece of plywood from front to rear. Bring the strap over the load and secure it. Repeat step for the other strap, but route it from left to right.
- 26 Using two 14-foot lengths of 1/2-inch tubular nylon webbing, route one length around the load about one-third of the way up the load. Secure it tight with a trucker's hitch knot. Repeat step for second length two-thirds of the way up the load.
- 27 Finish closing the container according to Figure 6-2.
- 28 Secure the skid board to the load according to Figure 6-5.

**Figure 7-3. GLLD Rigged (Continued)**

**CAUTION**

Make the final rigger inspection required by FM 4-20.102/NAVSEA SS400-AB-MMO-010/TO 13C7-1-5 and AR 59-4/OPNAVINST 4463.24C/AFJ 13-210(I)/MCO 13480.1B before the load leaves the rigging site.



**RIGGING LOAD DATA**

Weight with parachute .....	395-pounds
Height with parachute .....	42-inches
Width .....	42-inches
Length .....	30-inches
Parachute .....	G-14

**Figure 7-4. GLLD Rigged In An A-21 Cargo Bag For Low-Velocity Airdrop**

**Table 7-1. Equipment Required for Rigging the GLLD in an A-21 Cargo Bag for Low-Velocity Airdrop**

National Stock Number	Item	Quantity
8040-00-273-8713	Adhesive, paste, 1-gallon	As required
1670-00-242-9173	Bag, cargo, A-21	1
8305-00-242-3593	Cloth, cotton duck, 60-inches	As required
4020-00-240-2146	Cord, nylon, type III	As required
8135-00-664-6958	Cushioning material, packaging, cellulose wadding	As required
8305-00-958-3685	Felt, 1/2-inch thick	As required
1670-00-753-3928	Pad, energy-dissipating, honeycomb	2 sheets
1670-00-999-2658	Parachute, cargo, G-14	1
5530-00-128-4981	Plywood, 3/4- by 30- by 42-inch	3
1670-00-251-1153	Sling assembly, cargo, airdrop, A-7A	1
7510-00-266-6710	Tape, masking, 2-inch	As required
8310-01-102-4478	Thread, cotton, ticket number 8/7	As required
8305-00-268-2411	Webbing: Cotton, 1/4-inch, type I	As required
8305-00-082-5752	Nylon, tubular, 1/2-inch	As required

**This page intentionally left blank.**

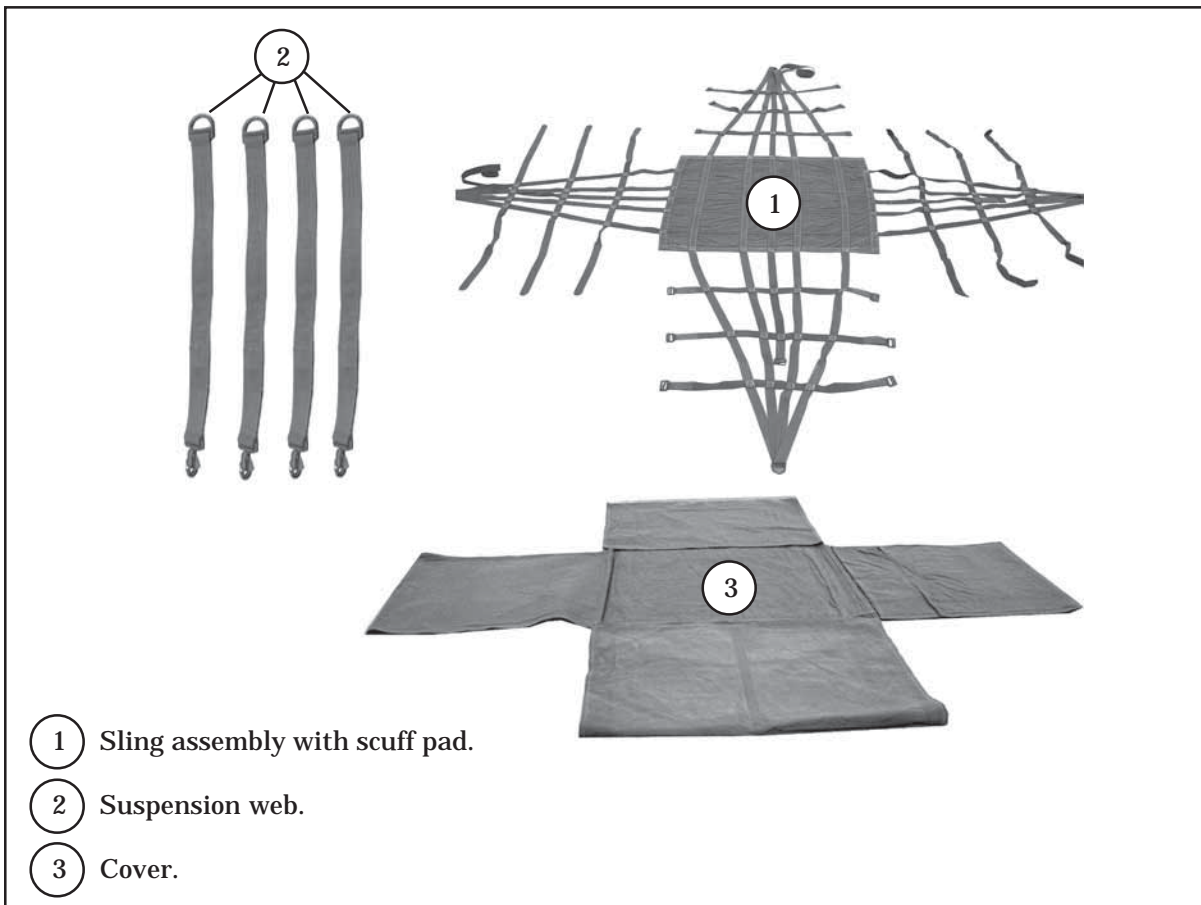
**PART FOUR**  
**RIGGING A-22 CONTAINER LOADS**

**Chapter 8**

**General Information and Procedures**

**A-22 CARGO BAG ASSEMBLY**

8-1. The A-22 cargo bag assembly is an adjustable cotton duck cloth and nylon webbing container. It consists of a sling assembly, a cover, and four suspension webs as shown in Figure 8-1. The load may be rigged with or without the cover.



**Figure 8-1. A-22 Cargo Bag**

## A-22 SKID BOARD

### CAUTION

When the skid board is locally fabricated, AC grade plywood must be used. Make sure the smooth side is facing down on the rollers.

8-2. The skid board is 1- by 48- by 48-inches for both low- and high-velocity drops. When dropping low-velocity loads weighing 501 to 1,600 pounds, a 3/4-inch thick skid board may be used. The skid board has sixteen 1/2-inch holes (four in each side), which are used to secure the skid board to the load. The skid board ties are made with 1/2-inch (or 5/8-inch) tubular nylon webbing. The length will vary according to the layers of honeycomb. Steel strapping will not be used to secure the skid board to the load unless specific rigging procedures authorize it.

**NOTE:** The steel strapping must not touch the aircraft's rollers.

## A-22 CONTAINER LIMITATIONS

8-3. The A-22 load has a weight range of 501 to 2,200 pounds, excluding the weight of the parachute. Ensure the load weighs the minimum of 28-pounds per square foot. The height of the load with parachute will not exceed 83 inches for C-130 aircraft or 101 inches for C-17 aircraft unless specific rigging procedures authorizes it. The width of the load must not exceed 48 inches.

### NOTES:

1. If the load is smaller than the length of the skid board, place honeycomb filler sheets vertically inside the A-22 container. The length of the A-22 container should equal the length of the skid board. This prevents the A-22 containers from shifting when the loads are restrained in the aircraft.
2. Any overhang must be placed to the front or rear of the container; overhang to the left or right will not fit in the CVRS or logistic rails.

## DOUBLE A-22 CARGO BAG

8-4. The double A-22 cargo bag is made using two A-22 cargo bags. The weight range is 900 to 2,200 pounds. The skid board is constructed of a 1- by 48- by 96-inch piece of plywood. When dropping loads weighing 900 to 1,600 pounds, a 3/4-inch thick skid board may be used. The skid board has twenty-four 1/2-inch holes used for skid board ties. Ensure the load weighs the minimum of 28 pounds per square foot. This load will also be rigged with the double "X" skid board ties.



**CAUTION**

When rigging double A-22 loads, make sure cotton and nylon sling assemblies are not mixed.

**STRETCH A-22 CARGO BAG**

8-5. The stretch A-22 cargo bag is made using two A-22 cargo bags. The weight range is 675 to 2,200 pounds. The skid board is constructed of a 1- by 48- by 72-inch piece of plywood. When dropping loads weighing 675 to 1,600 pounds, a 3/4-inch thick skid board may be used. The skid board has twenty-four 1/2-inch holes used for skid board ties. Ensure the load weighs the minimum of 28 pounds per square foot. This load will also be rigged with the double "X" skid board ties.

**ASSEMBLY LINE RIGGING**

8-6. When assembly line rigging is used for A-22 loads, only five stations are needed. FM 10-500-9 covers setting up the rigging line and stations. The five stations are laying out containers and preparing base, positioning load, rigging load, installing parachute, and inspecting the rigged load.

**INSPECTING LOAD**

8-7. The A-22 load must be inspected by a qualified rigger. While being rigged, this load should be supervised or rigged by a parachute rigger. DD Form 1748-1 (Joint Airdrop Inspection Record (Container)) must be completed before airdrop.

**PARACHUTES USED**

8-8. There are two types of parachutes used for A-22 loads, depending on whether the load is being dropped for low- or high-velocity. Each category has a primary and alternate parachute. The alternate should be used only when the primary parachute is not available.

a. **LOW-VELOCITY DROPS.**

(1) **Primary Parachute.** The G-12E cargo parachute is the primary parachute used for A-22 loads for low-velocity airdrop. It is rated for 501 to 2,200 pounds of suspended weight. A 68-inch pilot parachute is installed on the G-12E cargo parachute to deploy it. Other parachutes may be used to deploy the G-12E cargo parachute; however, the specific manual must give the procedures. TM 10-1670-281-23&P/TO 13C5-32-2 covers the inspection and packing of the G-12E cargo parachute and the 68-inch pilot parachute.

**NOTE:** Suspended weight is the total weight of the load without the parachute attached.

(2) **Alternate Parachute.** The G-14 cargo parachute is the alternate parachute used for A-22 loads for low-velocity airdrop. It is used in a cluster of two or three parachutes. The two clustered parachute is used for loads containing 501 to 1,000 pounds of suspended weight and the three clustered parachute is used for loads containing, 1,001 to 1,500 pounds of suspended weight. TM 10-1670-282-23&P/TO 13C5-30-2 covers the inspection and packing of the G-14 cargo parachute.

b. **HIGH-VELOCITY DROPS.**

(1) **Primary Parachute.** The 26-foot, high-velocity cargo parachute is the primary parachute used for A-22 airdrops high-velocity. The parachute is rated from 501 to 2,200 pounds. TM 10-1670-276-23&P/TO 13C5-29-2/NAVAIR 13-1-29 covers the inspection and packing of the parachute.

(2) **Alternate Parachute.** The 22-foot cargo extraction parachute is the alternate parachute used for A-22 high-velocity airdrops. It is rated for 501- to 2,200 pounds of suspended weight. TM 10-1670-279-23&P/TO 13C5-27-2/NAVAIR 13-1-28 covers the inspection and packing of the parachute.

## INSTALLING PARACHUTES

8-9. Parachutes should be installed as follows:

- a. Install the G-12E cargo parachute as shown in Figure 8-2.
- b. Install two G-14 cargo parachutes as shown in Figure 8-3.
- c. Install three G-14 cargo parachutes as shown in Figure 8-4.
- d. Install the 26-foot, high-velocity cargo parachute as shown in Figure 8-5.
- e. Install the 22-foot, cargo extraction parachute as shown in Figure 8-6.

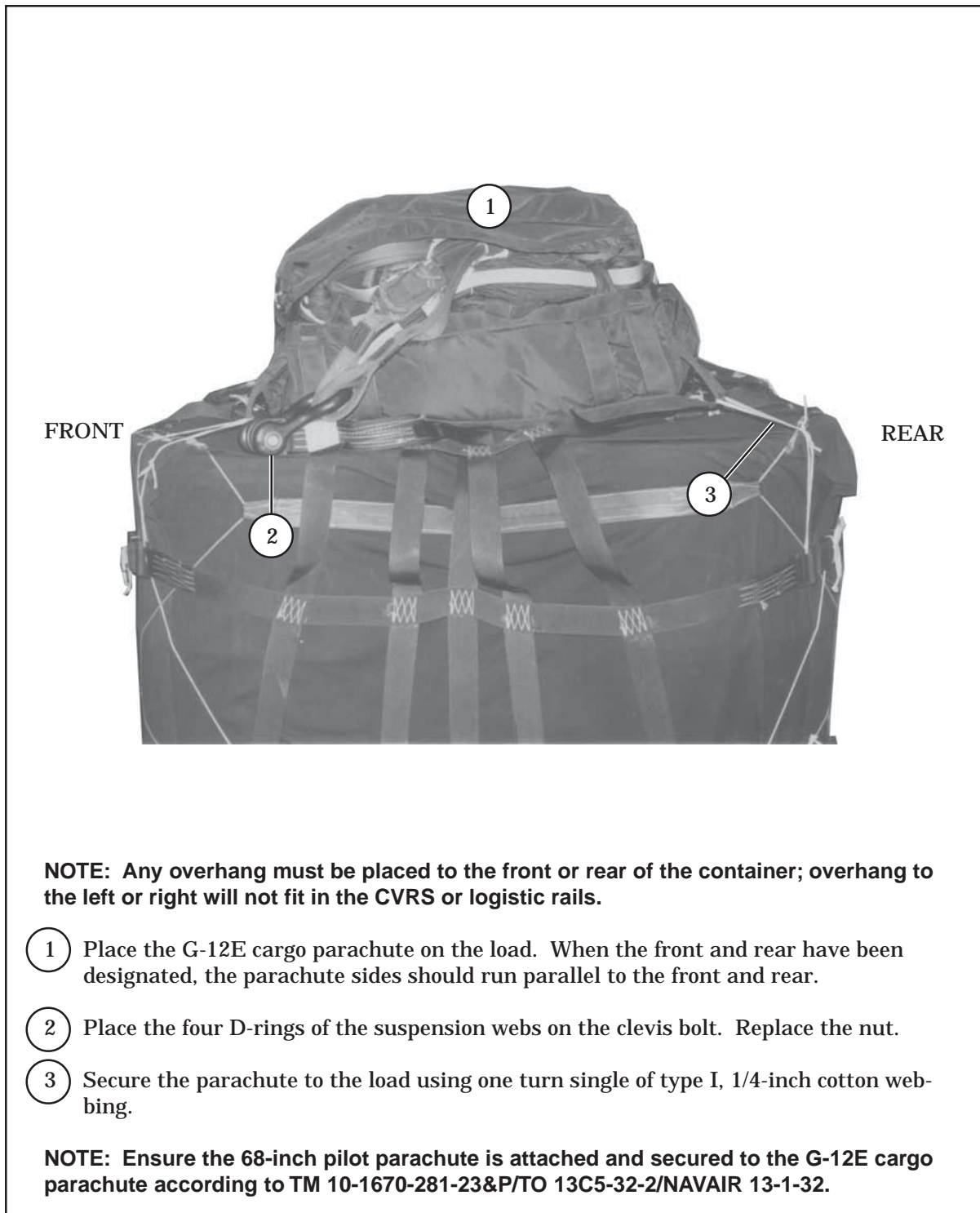
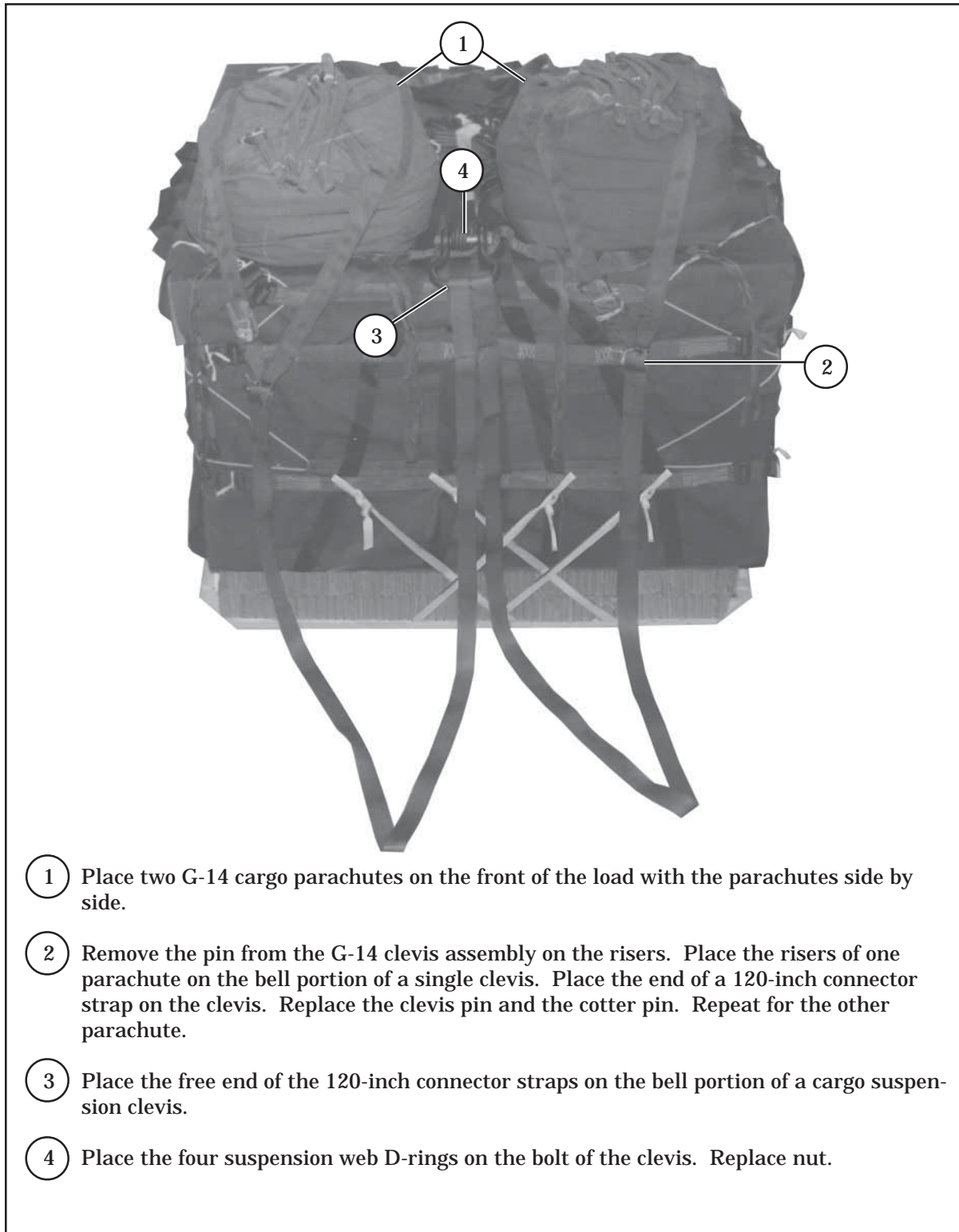
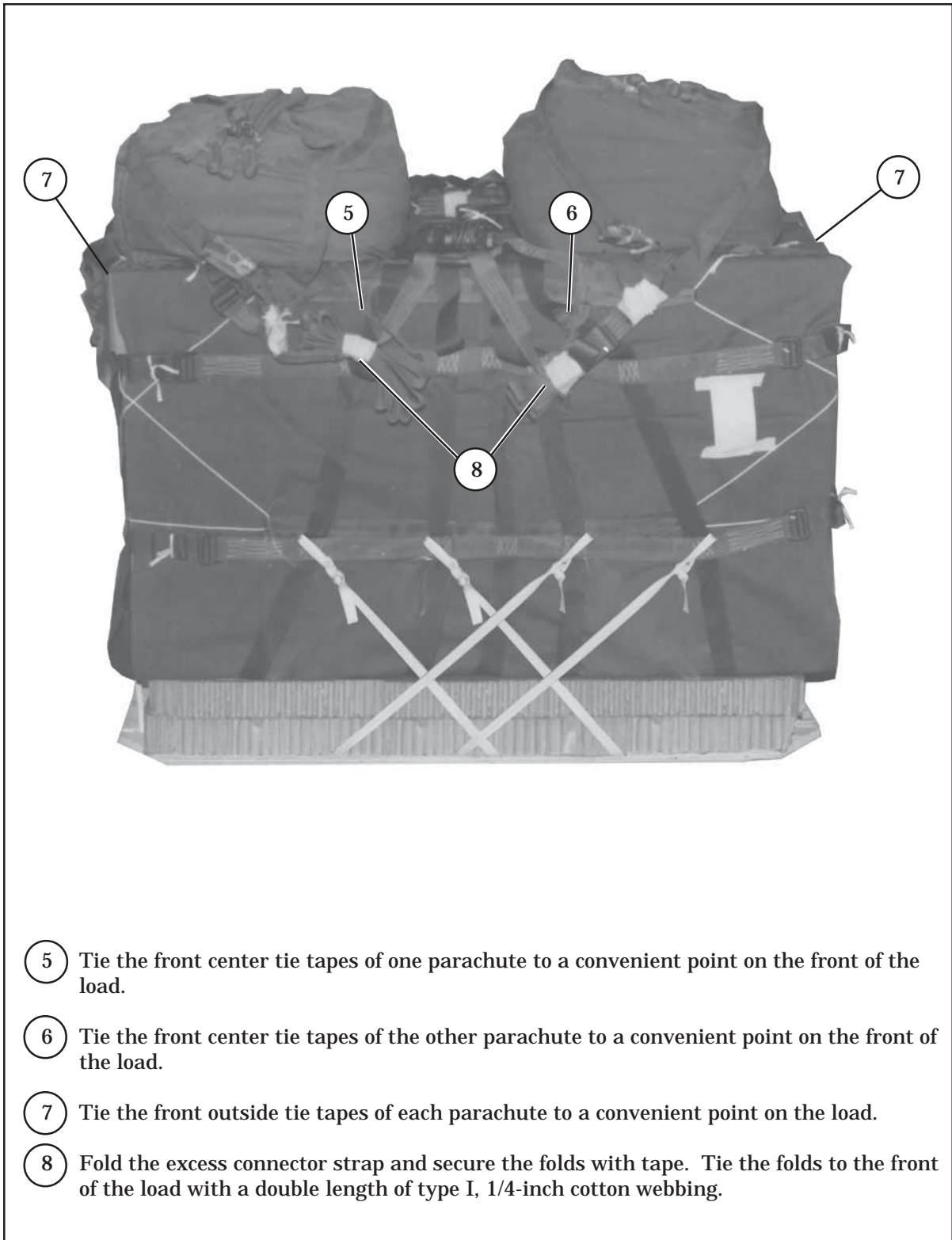


Figure 8-2. G-12E Cargo Parachute Installed



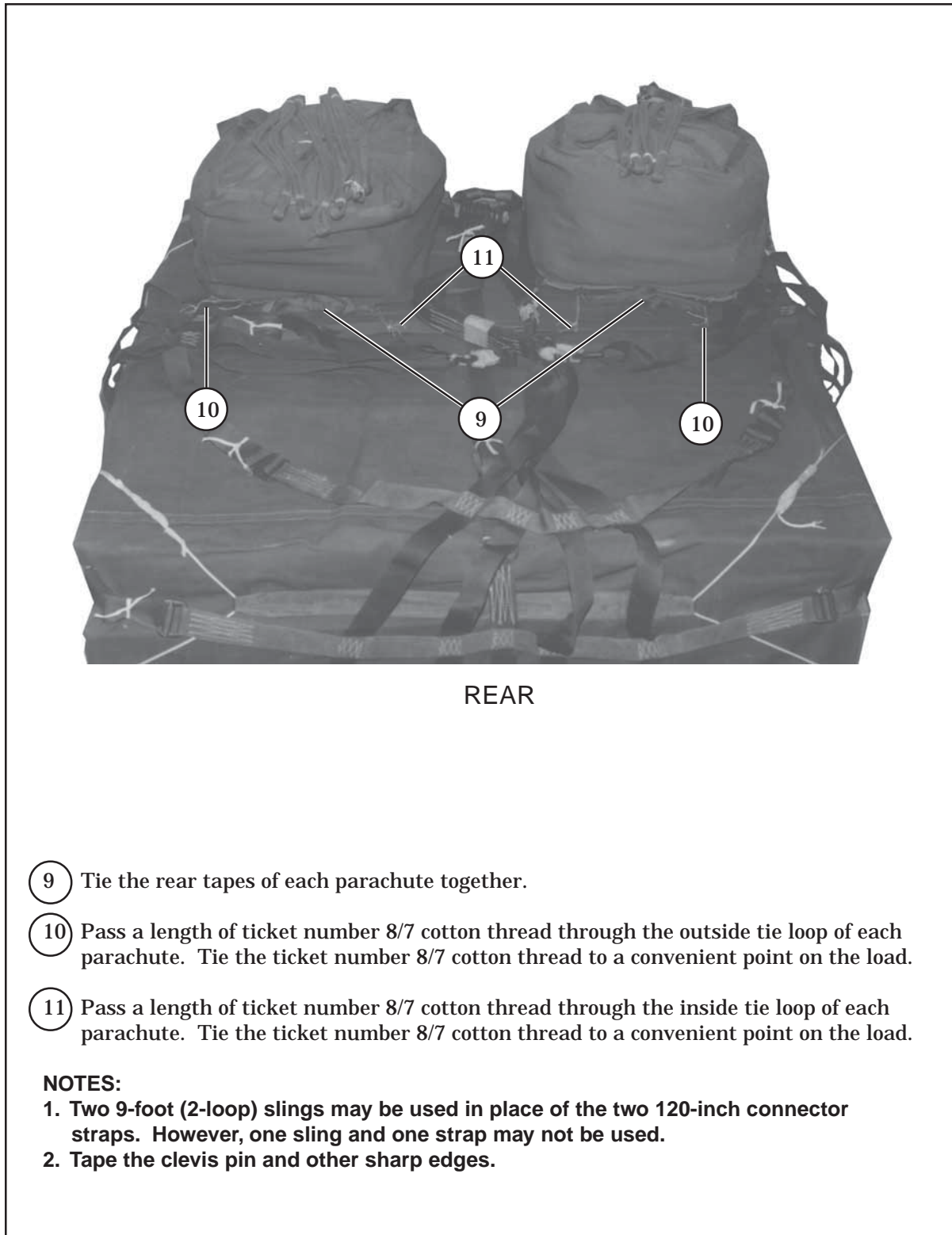
- ① Place two G-14 cargo parachutes on the front of the load with the parachutes side by side.
- ② Remove the pin from the G-14 clevis assembly on the risers. Place the risers of one parachute on the bell portion of a single clevis. Place the end of a 120-inch connector strap on the clevis. Replace the clevis pin and the cotter pin. Repeat for the other parachute.
- ③ Place the free end of the 120-inch connector straps on the bell portion of a cargo suspension clevis.
- ④ Place the four suspension web D-rings on the bolt of the clevis. Replace nut.

Figure 8-3. Two G-14 Cargo Parachutes Installed



- 5 Tie the front center tie tapes of one parachute to a convenient point on the front of the load.
- 6 Tie the front center tie tapes of the other parachute to a convenient point on the front of the load.
- 7 Tie the front outside tie tapes of each parachute to a convenient point on the load.
- 8 Fold the excess connector strap and secure the folds with tape. Tie the folds to the front of the load with a double length of type I, 1/4-inch cotton webbing.

**Figure 8-3. Two G-14 Cargo Parachutes Installed (Continued)**

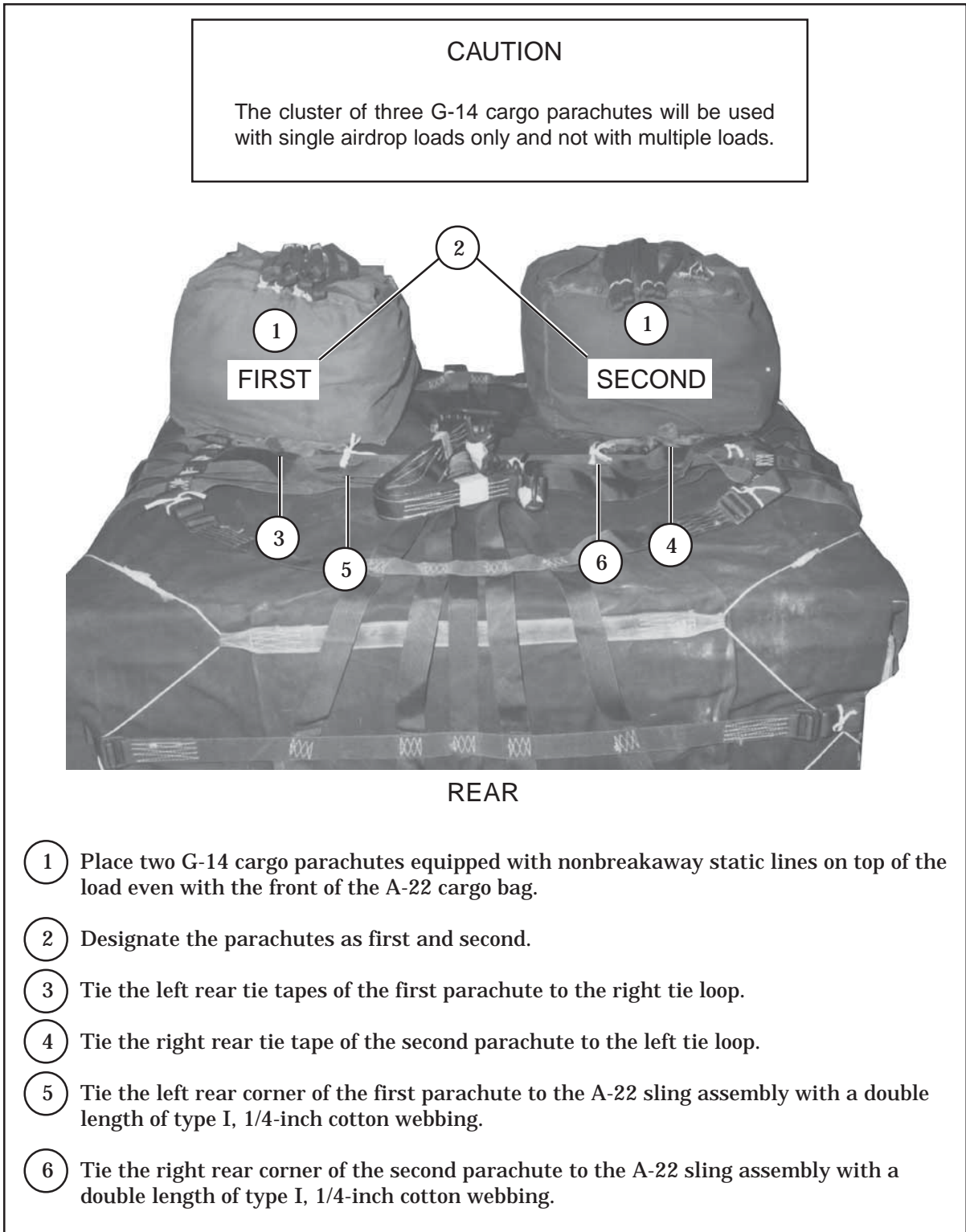


- 9 Tie the rear tapes of each parachute together.
- 10 Pass a length of ticket number 8/7 cotton thread through the outside tie loop of each parachute. Tie the ticket number 8/7 cotton thread to a convenient point on the load.
- 11 Pass a length of ticket number 8/7 cotton thread through the inside tie loop of each parachute. Tie the ticket number 8/7 cotton thread to a convenient point on the load.

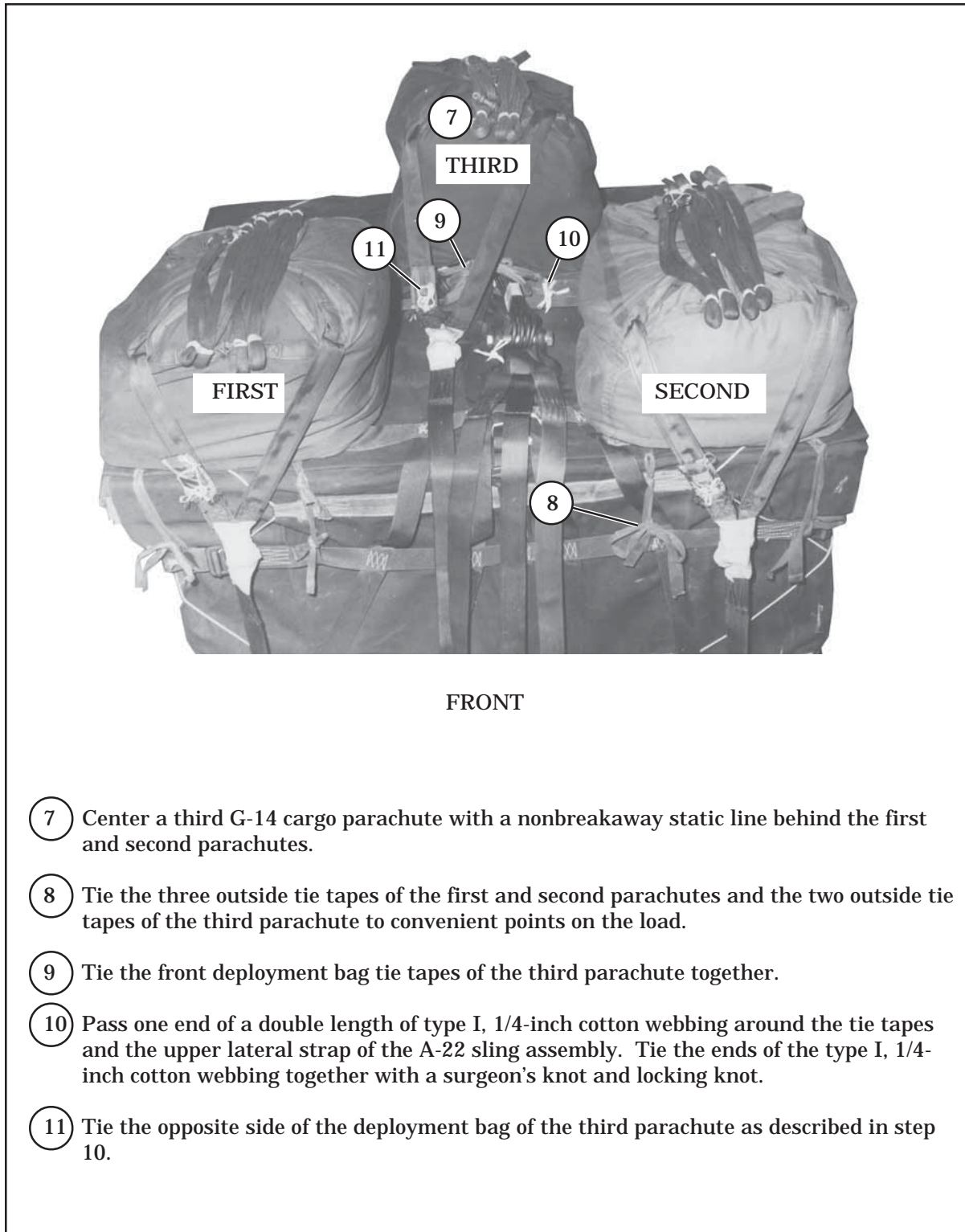
**NOTES:**

- 1. Two 9-foot (2-loop) slings may be used in place of the two 120-inch connector straps. However, one sling and one strap may not be used.
- 2. Tape the clevis pin and other sharp edges.

Figure 8-3. Two G-14 Cargo Parachutes Installed (Continued)



**Figure 8-4. Three G-14 Cargo Parachutes Installed**



- ⑦ Center a third G-14 cargo parachute with a nonbreakaway static line behind the first and second parachutes.
- ⑧ Tie the three outside tie tapes of the first and second parachutes and the two outside tie tapes of the third parachute to convenient points on the load.
- ⑨ Tie the front deployment bag tie tapes of the third parachute together.
- ⑩ Pass one end of a double length of type I, 1/4-inch cotton webbing around the tie tapes and the upper lateral strap of the A-22 sling assembly. Tie the ends of the type I, 1/4-inch cotton webbing together with a surgeon's knot and locking knot.
- ⑪ Tie the opposite side of the deployment bag of the third parachute as described in step 10.

Figure 8-4. Three G-14 Cargo Parachutes Installed (Continued)



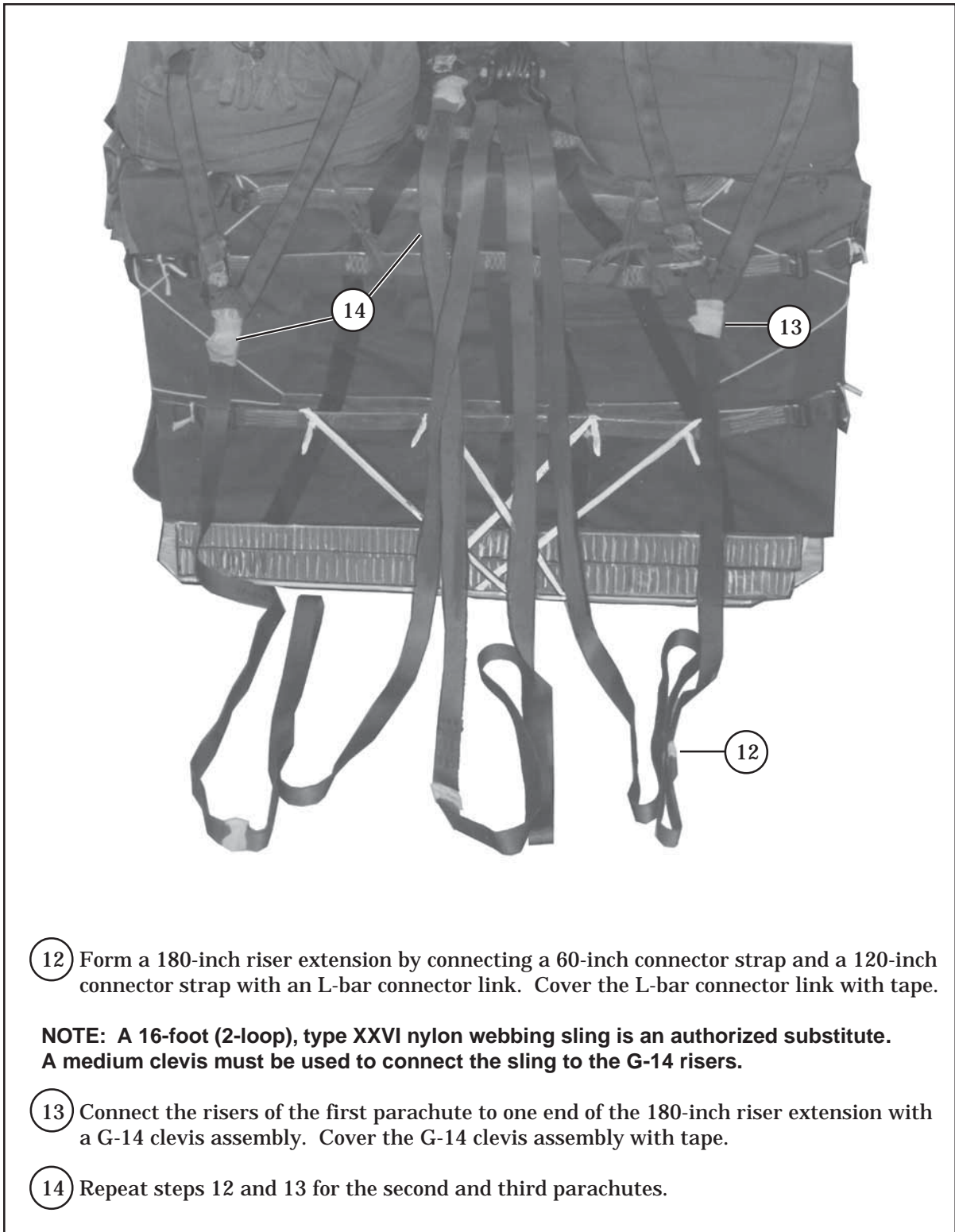
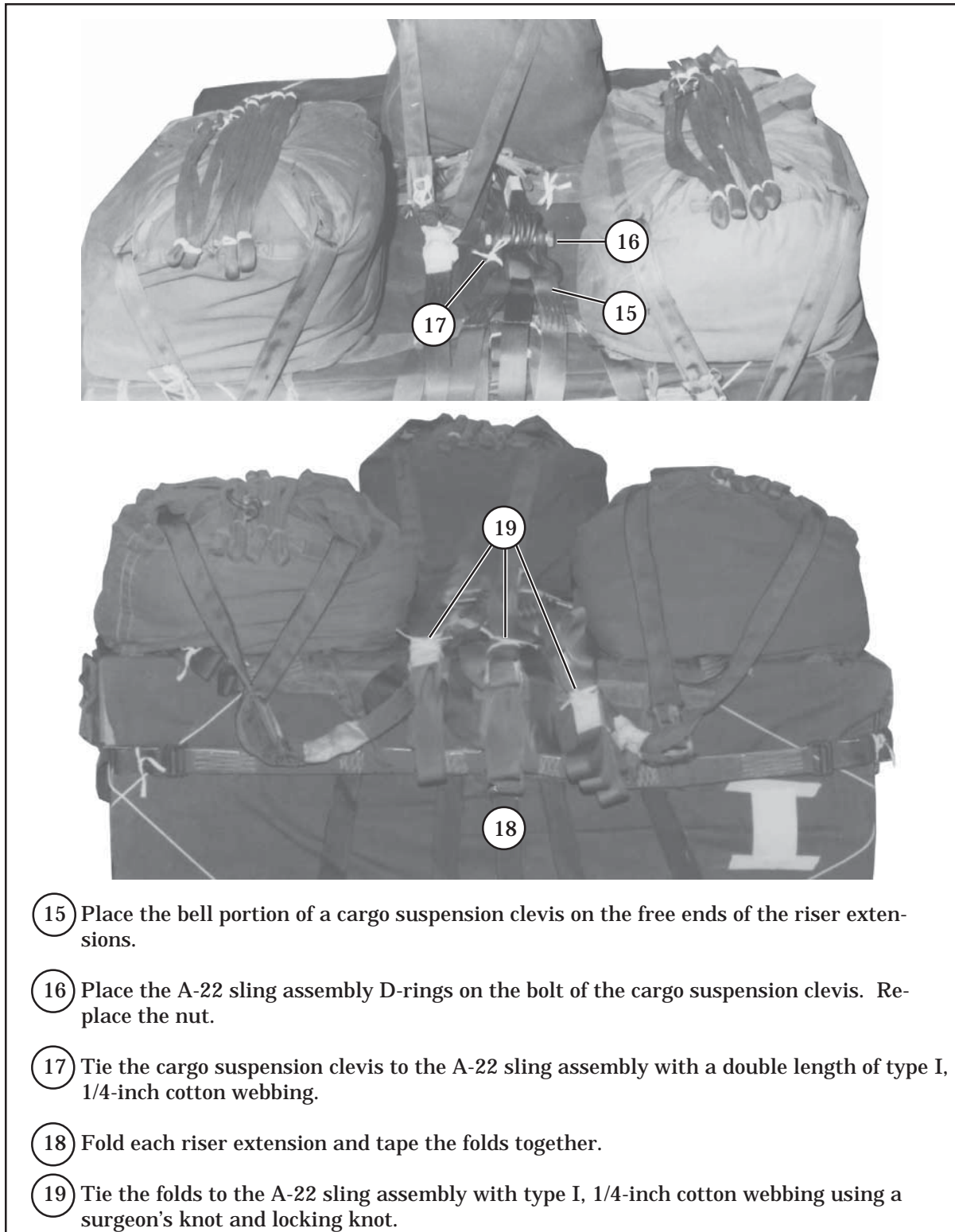
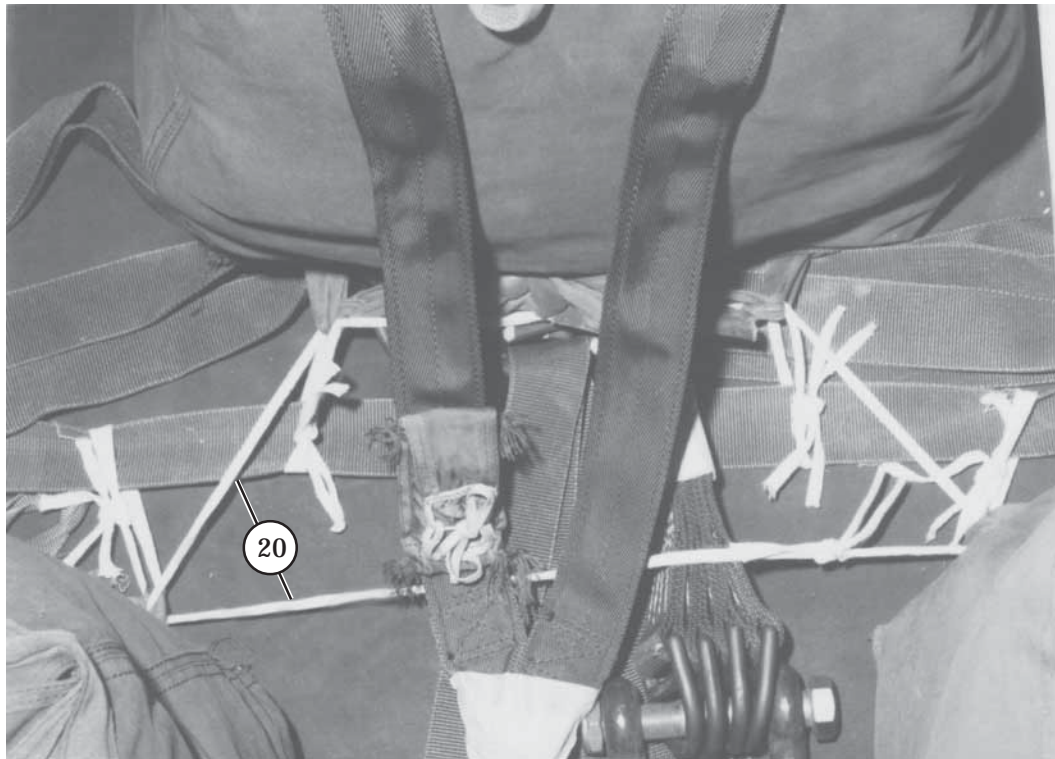


Figure 8-4. Three G-14 Cargo Parachutes Installed (Continued)



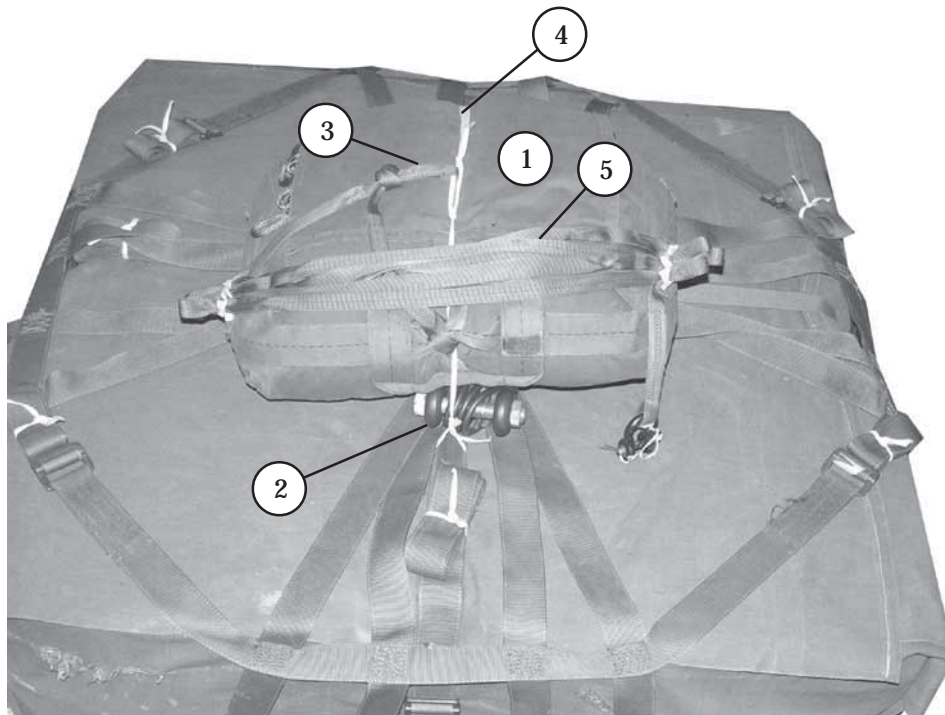
- 15 Place the bell portion of a cargo suspension clevis on the free ends of the riser extensions.
- 16 Place the A-22 sling assembly D-rings on the bolt of the cargo suspension clevis. Replace the nut.
- 17 Tie the cargo suspension clevis to the A-22 sling assembly with a double length of type I, 1/4-inch cotton webbing.
- 18 Fold each riser extension and tape the folds together.
- 19 Tie the folds to the A-22 sling assembly with type I, 1/4-inch cotton webbing using a surgeon's knot and locking knot.

Figure 8-4. Three G-14 Cargo Parachutes Installed (Continued)



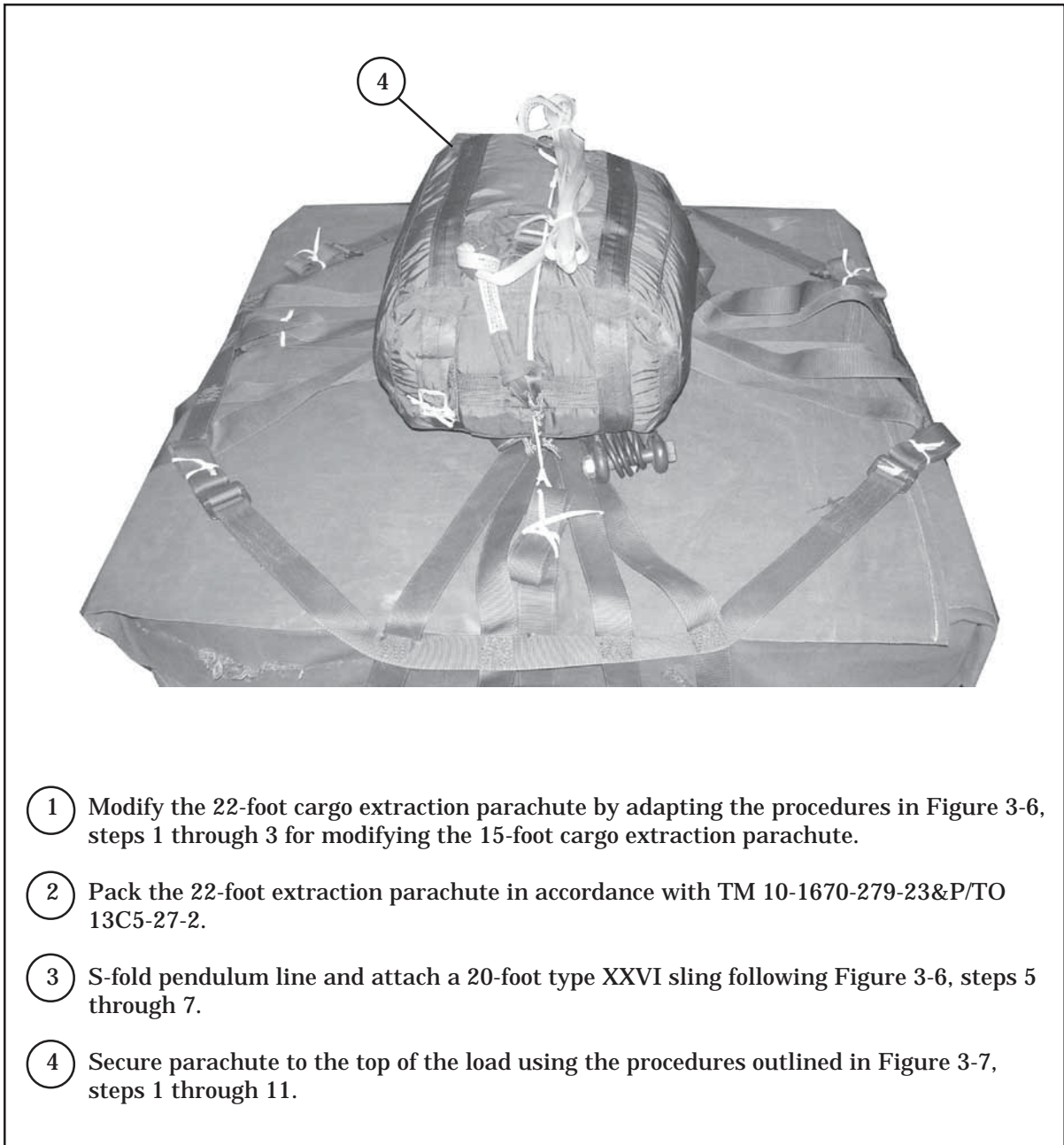
- 20 Safety the three cargo parachutes together with one length of type I, 1/4-inch cotton webbing. Pass the webbing through the inside bag closing tie loops of the deployment bags. Tie the ends of the webbing together with a surgeon's knot and locking knot.

**Figure 8-4. Three G-14 Cargo Parachutes Installed (Continued)**



- 1 Place a 26-foot, high-velocity cargo parachute on top of the load.
- 2 Place the suspension web D-rings on the bolt of the cargo suspension clevis.
- 3 Form a 3-inch diameter loop in the static line by tying an overhand knot approximately 12 inches up from the deployment bag main strap attaching loop.
- 4 Tie one end of a length of type I, 1/4-inch cotton webbing to a convenient point on the A-22 container. Pass the free end of the cotton webbing through the deployment bag main strap attaching loop, through the loop in the static line around a convenient point on the load and secure using a trucker's hitch knot.
- 5 Stow the static line according to TM 10-1670-276-23&P/TO 13C5-29-2/NAVAIR 13-1-29.

**Figure 8-5. One 26-Foot High-Velocity Cargo Parachute Installed**



- ① Modify the 22-foot cargo extraction parachute by adapting the procedures in Figure 3-6, steps 1 through 3 for modifying the 15-foot cargo extraction parachute.
- ② Pack the 22-foot extraction parachute in accordance with TM 10-1670-279-23&P/TO 13C5-27-2.
- ③ S-fold pendulum line and attach a 20-foot type XXVI sling following Figure 3-6, steps 5 through 7.
- ④ Secure parachute to the top of the load using the procedures outlined in Figure 3-7, steps 1 through 11.

**Figure 8-6. One 22-Foot Cargo Extraction Parachute Installed**

**This page intentionally left blank.**

## Chapter 9

# Rigging Typical A-22 Loads

### SECTION I - RIGGING A-22 LOADS FOR LOW-VELOCITY AIRDROP

#### DESCRIPTION OF LOAD

9-1. A typical load is rigged for low-velocity airdrop using an A-22 cargo bag. Typical loads include rations, repair parts, water cans, and other small items. Items to be dropped may be rigged in their original shipping container or may be repacked for airdrop. A-22 container loads must weigh between 501 and 2,200 pounds, excluding the weight of the parachute. The load is rigged with one G-12E cargo parachute with a 68-inch diameter pilot parachute. See Chapter 2 for aircraft capabilities and limitations.

#### PREPARING DROP ITEMS

9-2. Prepare the drop items according to the load's sensitivity. Items must be well padded to prevent damage during airdrop. Items must also be padded or containerized to prevent them from falling out of the container during airdrop.

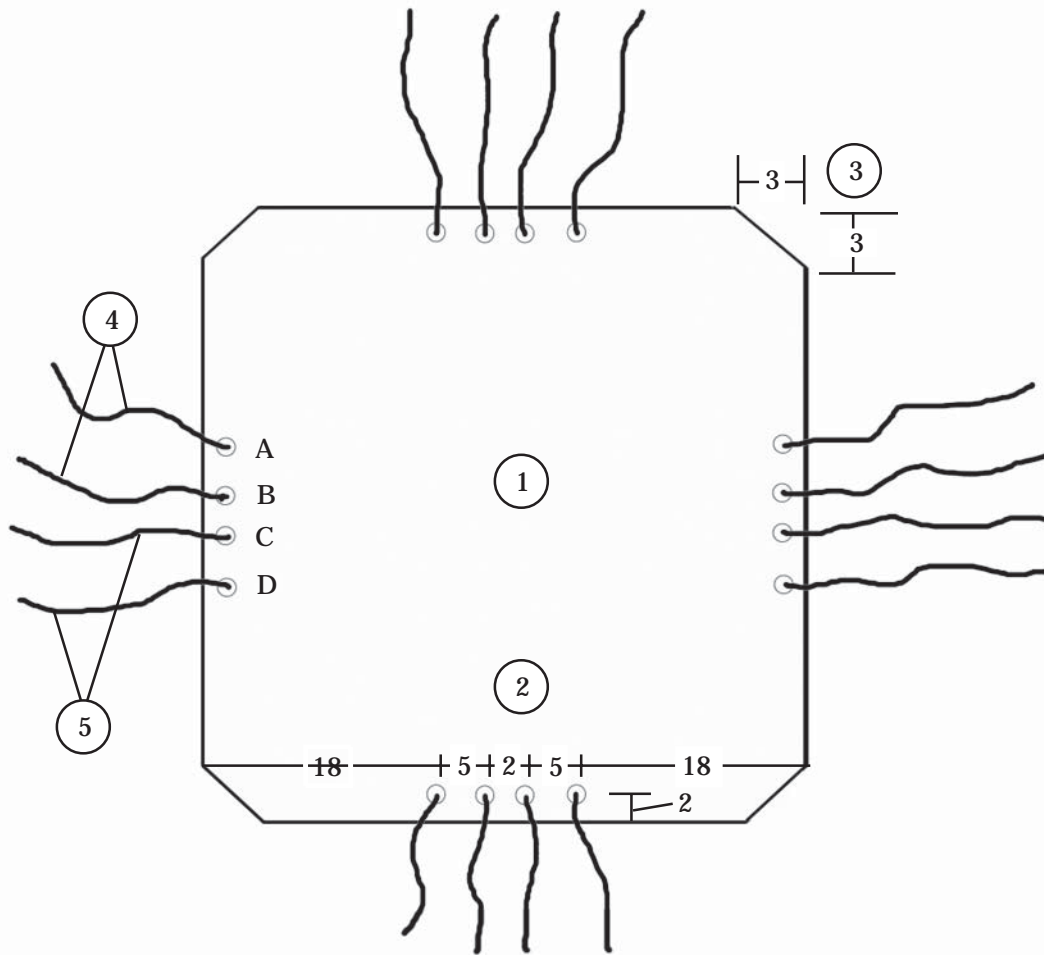
#### PREPARING SKID BOARD

9-3. Prepare a locally fabricated skid board as shown in Figure 9-1.

**NOTE:** Precut skid boards ordered by National Stock Number (NSN) DO NOT require the preparation shown in Figure 9-1.

**NOTES:**

1. This drawing is not drawn to scale.
2. All dimensions are given in inches.
3. Use only AC grade plywood for skid boards.



- ① Place a 3/4- or 1- by 48- by 48-inch piece of plywood on a flat surface.
- ② Drill four 1/2-inch holes on each side as shown above.
- ③ Measure 3 inches in from each corner of the skid board and make a diagonal cut.
- ④ Cut eight 8-foot lengths of 1/2-inch tubular nylon webbing. Route one length through hole A from the bottom and the other end through hole B from the bottom. Even the ends.
- ⑤ Repeat step 3 for holes C and D and remaining sides.

**Figure 9-1. Locally Fabricated Skid Board Prepared for Single A-22 Load**



## POSITIONING HONEYCOMB

9-4. Position honeycomb as shown in Figure 9-2. Glue the pieces of honeycomb together; however, the stack does not have to be glued to the skid board.

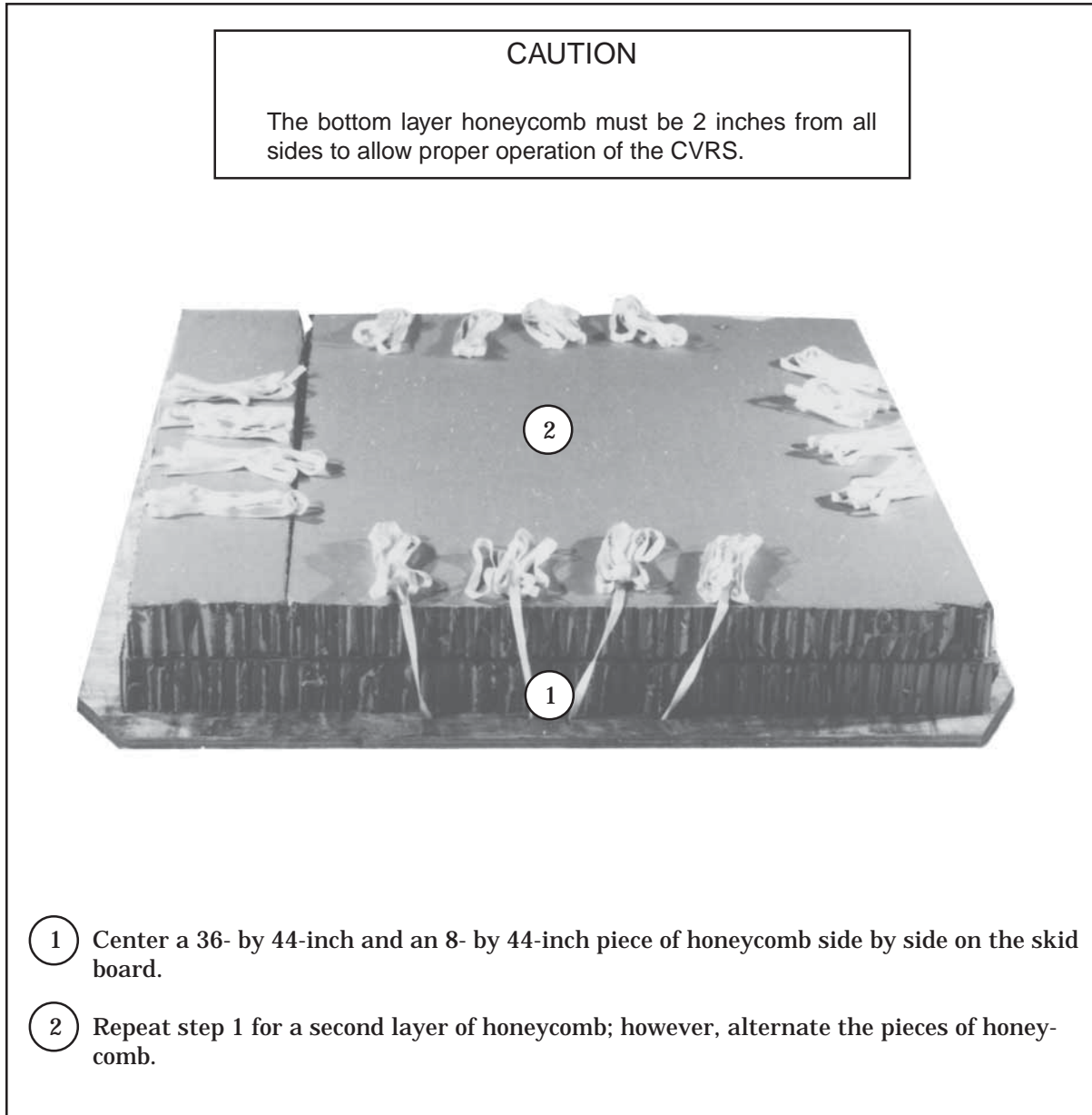


Figure 9-2. Honeycomb Positioned on Skid Board

## POSITIONING A-22 CARGO BAG SLING, COVER, AND LOAD

9-5. Position the A-22 cargo bag sling, cover, and load as shown in Figure 9-3.

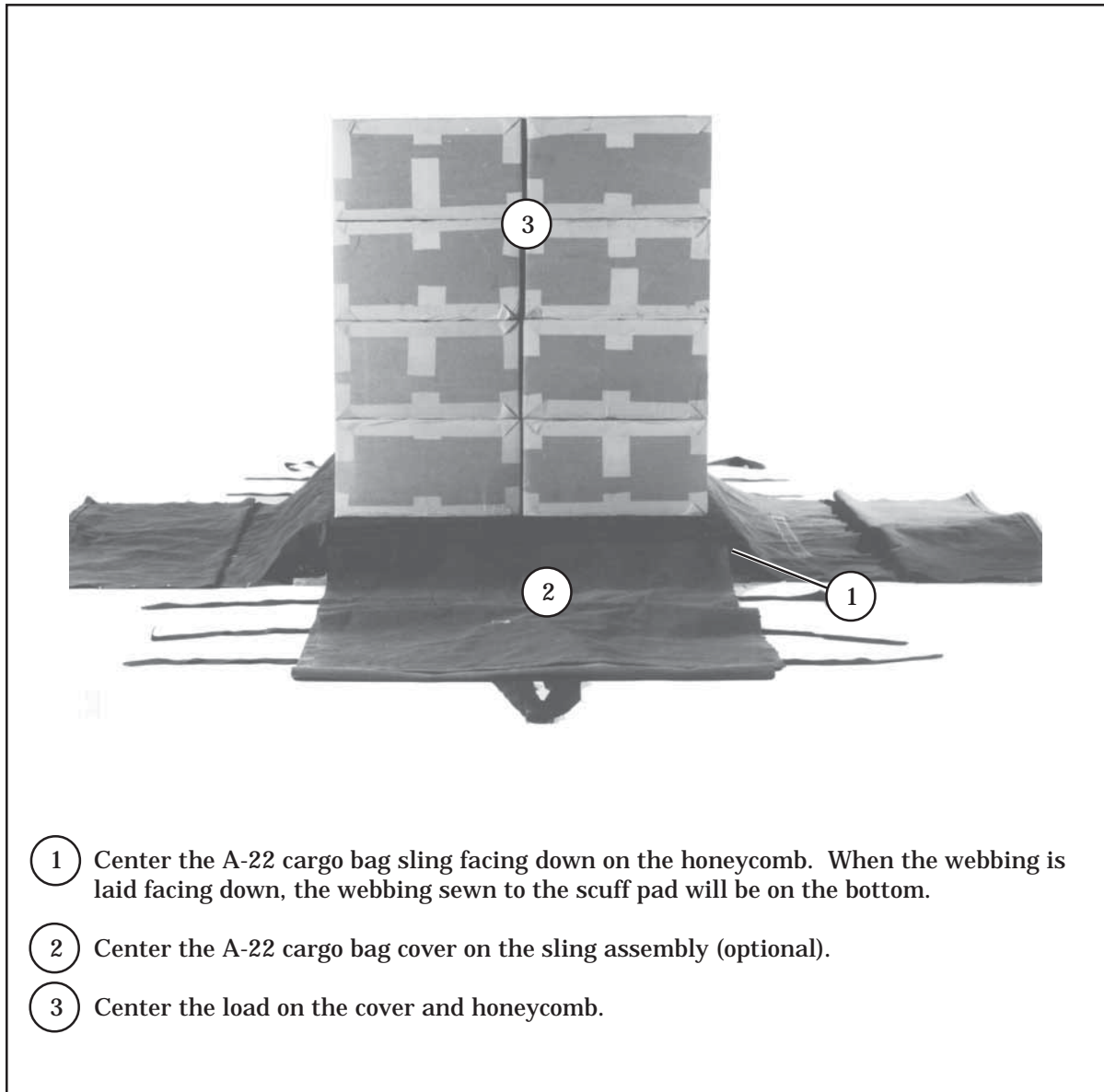


Figure 9-3. A-22 Cargo Bag Sling, Cover, and Load Positioned

## SECURING A-22 CARGO BAG COVER

9-6. Secure the A-22 cargo bag cover over the load as shown in Figure 9-4.

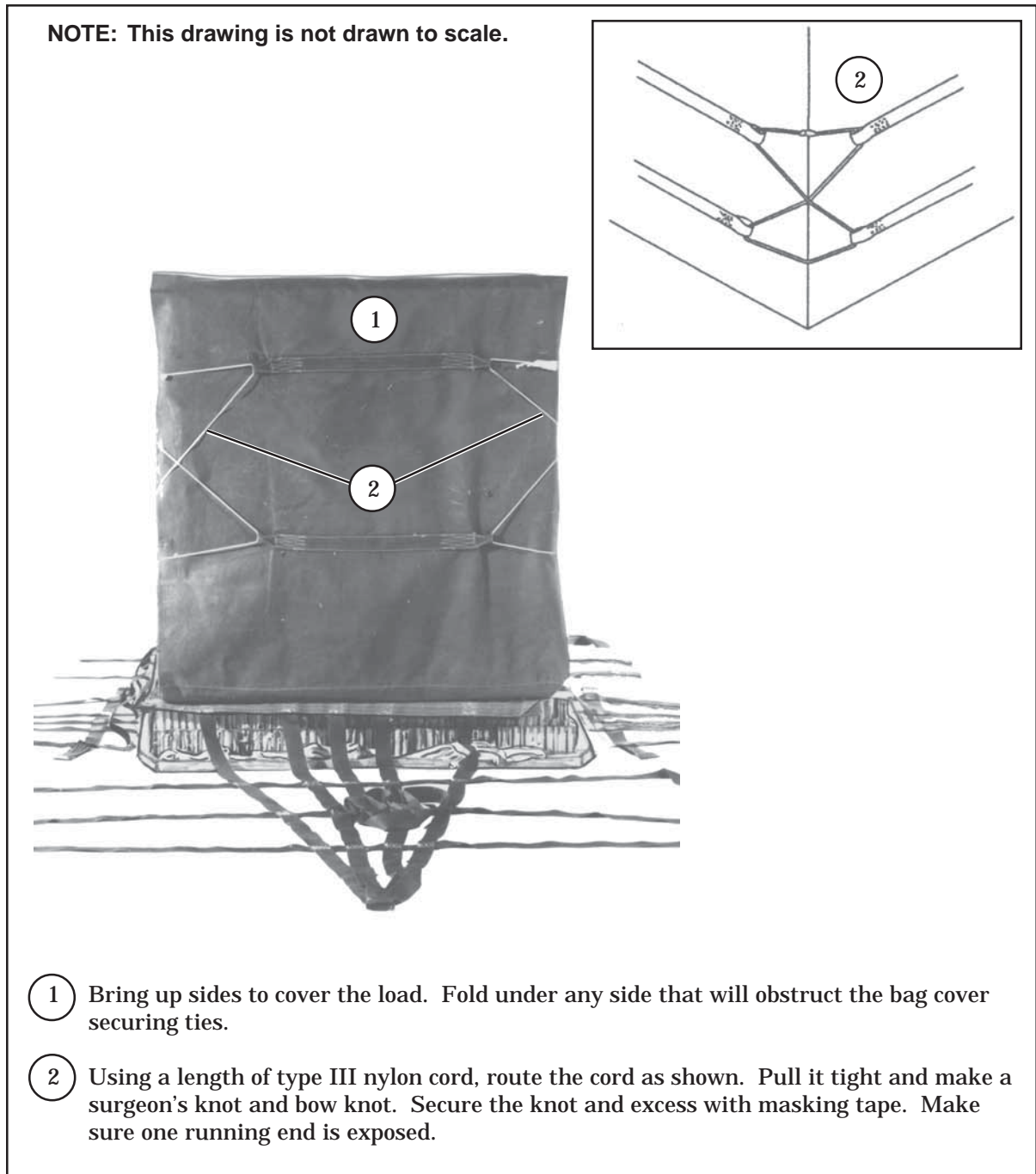


Figure 9-4. A-22 Cargo Bag Cover Secured

## SECURING A-22 CARGO BAG SLING

9-7. Secure the sling assembly according to Figure 9-5.

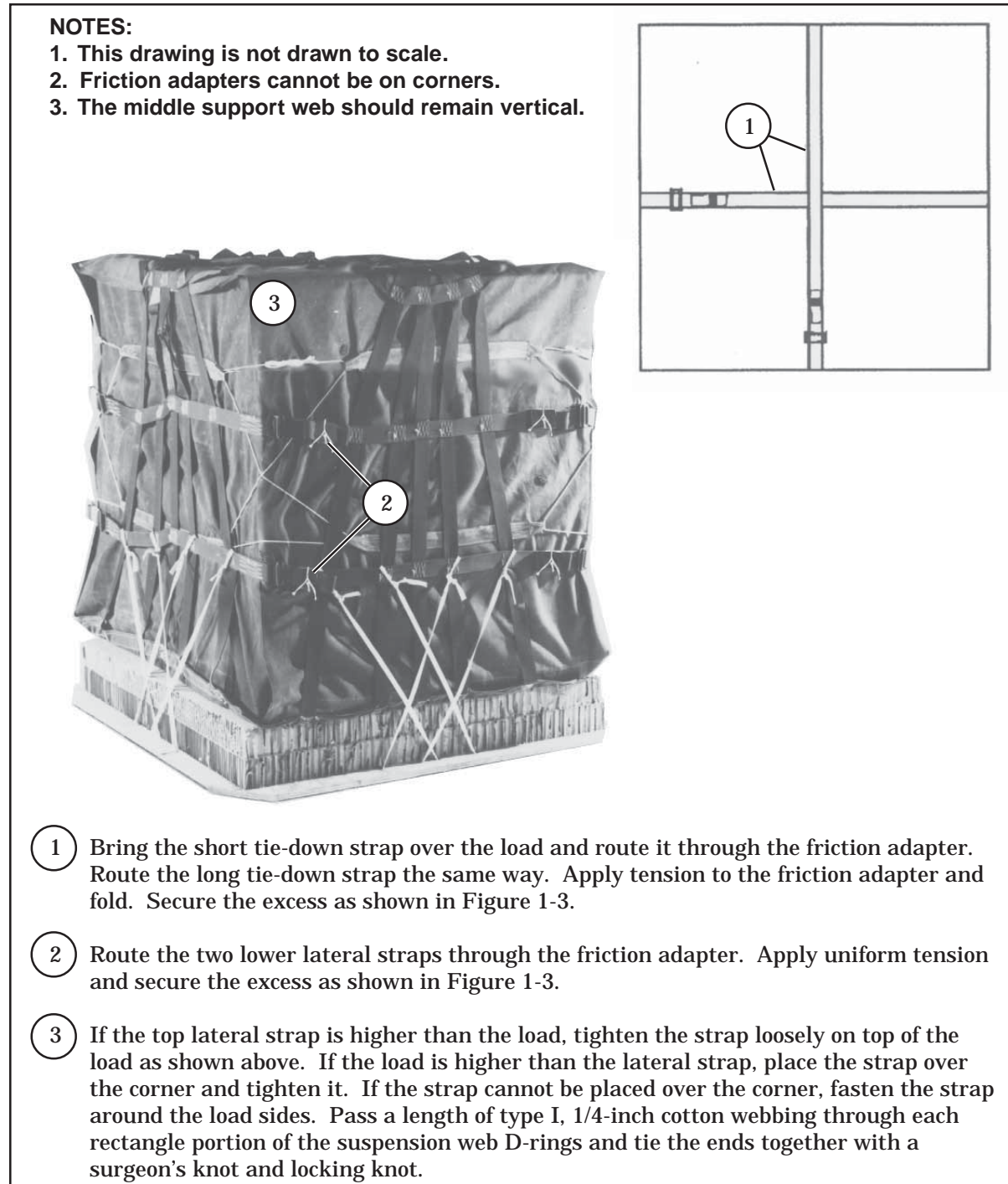


Figure 9-5. A-22 Cargo Bag Sling Secured

## SECURING SKID BOARD TO A-22 CARGO BAG

9-8. Secure the skid board to the A-22 cargo bag as shown in Figure 9-6. When tightening straps, make sure excess tension is not applied causing the sewn portion at the intersection of lateral straps and support web to separate.

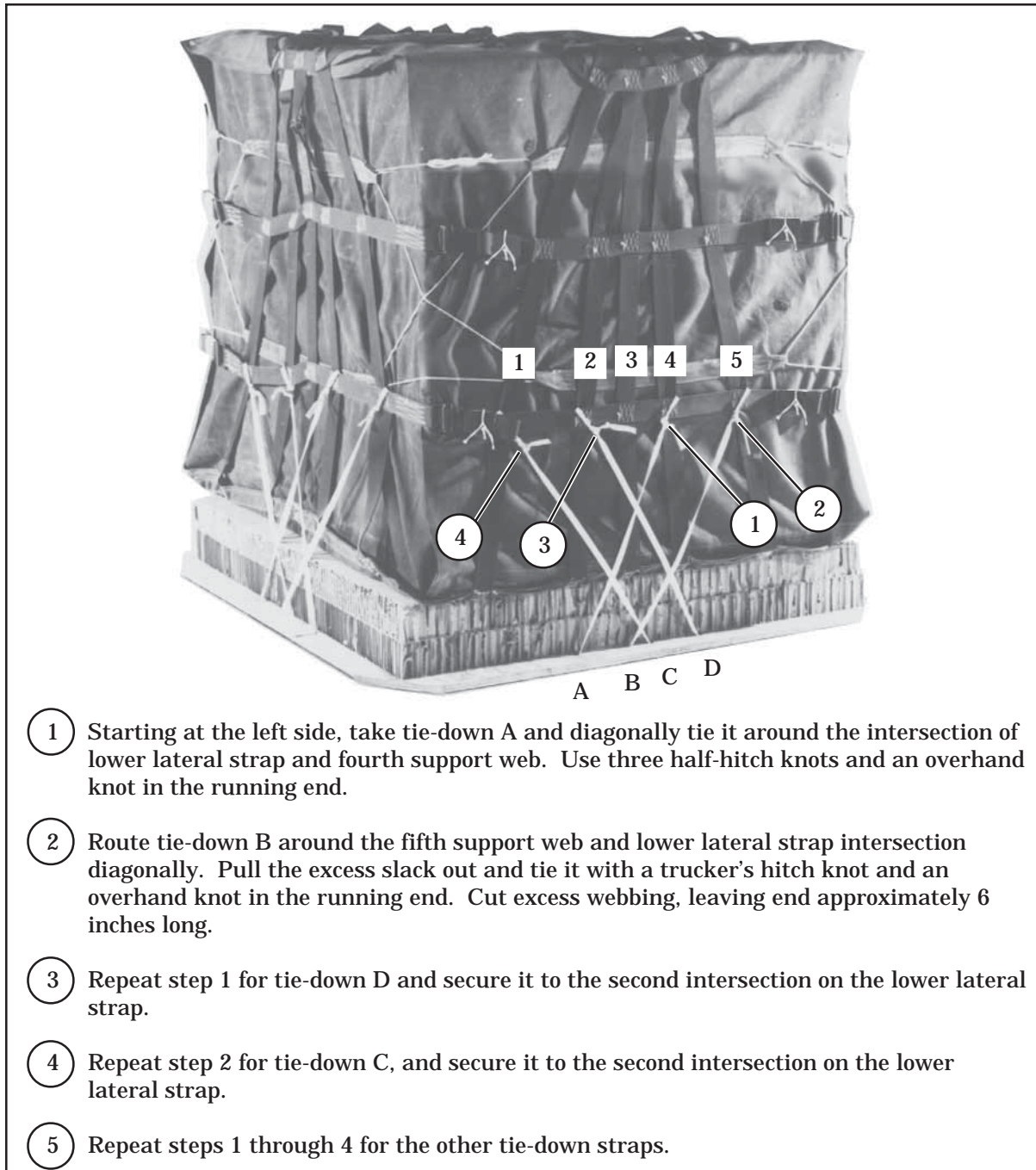


Figure 9-6. Skid Board Secured to A-22 Bag

## ATTACHING SUSPENSION WEBS

9-9. Attach four suspension webs as shown in Figure 9-7.

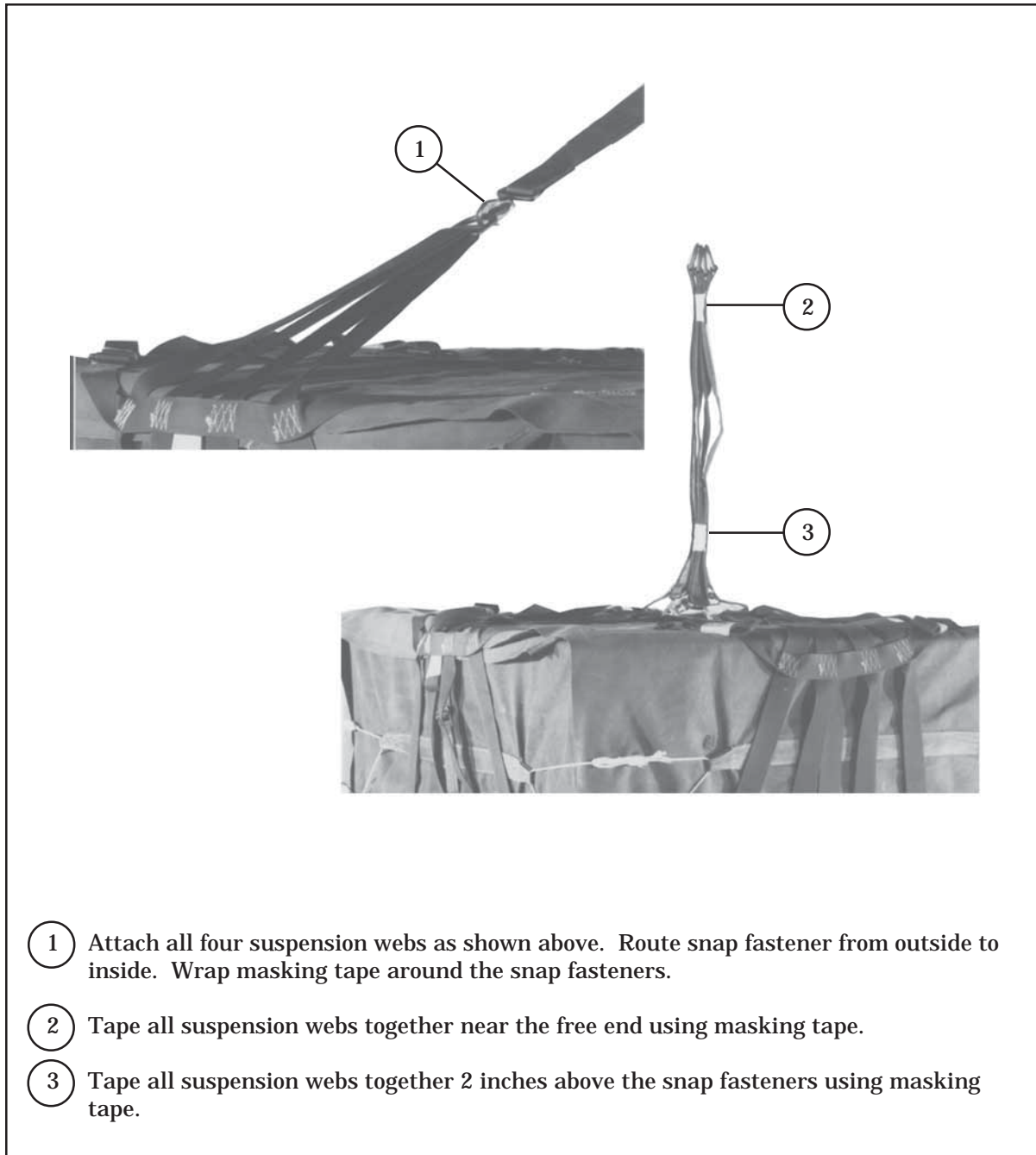


Figure 9-7. Suspension Webs Attached

## INSTALLING PARACHUTE

9-10. Install the G-12E cargo parachute according to Chapter 8.

## MARKING RIGGED LOAD

9-11. Mark the rigged load according to Chapter 1. Compute the rigged load data.

### CAUTION

Make the final rigger inspection required by FM 4-20.102/ NAVSEA SS400-AB-MMO-010/TO 13C7-1-5 and AR 59-4/OPNAVINST 4630.24C/AFJ 13-210(I)/MCO 13480.1B before the load leaves the rigging site.



### RIGGING LOAD DATA (without parachute)

G-12E cargo parachute ..... 501 - 2,200 pounds

Figure 9-8. A-22 Container Load Rigged for Low-Velocity Airdrop

## EQUIPMENT REQUIRED

9-12. Use the equipment listed in Table 9-1 to rig the load shown in Figure 9-8.

Table 9-1. Equipment Required for Rigging an A-22 Container Load for Low-Velocity Airdrop

National Stock Number	Item	Quantity
8040-00-273-8713	Adhesive, paste, 1-gallon	As required
1670-00-587-3421	Bag, cargo, A-22	1
4030-00-678-8562	Clevis, suspension, 3/4-inch (medium)	1
4020-00-240-2146	Cord, nylon, type III	As required
1670-00-753-3928	Pad, energy-dissipating material, honeycomb	2 sheets
1670-01-065-3755	Parachute, cargo, G-12E	1
5530-00-128-4981	Plywood: 3/4- by 48- by 96-inch (locally fabricated skid board) or 1- by 48- by 96-inch	1 sheet
5530-00-914-5118	Tape, masking, 2-inch	As required
7510-00-266-6710	Thread, cotton, ticket number 8/7	As required
8310-01-102-4478	Webbing: Cotton, 1/4-inch, type I	As required
8305-00-268-2411	Nylon, tubular, 1/2-inch	As required
8305-00-082-5752		As required

## SECTION II - RIGGING A-22 LOADS FOR HIGH-VELOCITY AIRDROP

### DESCRIPTION OF LOAD

9-13. A typical load is rigged for high-velocity airdrop using the A-22 cargo bag. Typical loads include rations, repair parts, water cans, and other small items. Items may be dropped in their original package or repacked for greater protection. See Chapter 2 for aircraft capabilities and limitations.

### PREPARING ITEMS AND SKID BOARD

9-14. Refer to Paragraph 9-2 to prepare the items. Use 1-inch thick plywood to prepare a skid board according to Paragraph 9-3.



**POSITIONING HONEYCOMB**

9-15. Use Table 9-2 to determine the number and size of honeycomb layers. Honeycomb layers should be glued together; however, the stack does not have to be glued to the skid board. See Figure 9-9 for loads weighing less than 1,100 pounds. See Figure 9-10 for loads weighing more than 1,100 pounds.

**NOTE:** The maximum width of the top three layers of honeycomb is 48 inches.

**Table 9-2. Honeycomb Sizes for High-Velocity A-22 Loads**

Weight of Load (Pounds)	Layer Number	Pieces	Length (Inches)	Width (Inches)	
501 - 1,100	1	1	44	36	
		1	44	8	
	2	3	44	8	
		1	48	36	
	3	1	48	12	
		3	48	12	
	4	1	48	36	
		1	48	12	
	1,100 - 2,200	1	1	44	36
			1	44	8
2		1	44	36	
		1	44	8	
3		1	48	36	
		1	48	12	
4		1	48	36	
		1	48	12	
5		1	48	36	
		1	48	12	

**NOTE:** On loads weighing 1,000 to 1,100 pounds, either stack formation may be used.

**CAUTION**

Loads over 1,300 pounds will not have full energy absorption on impact.

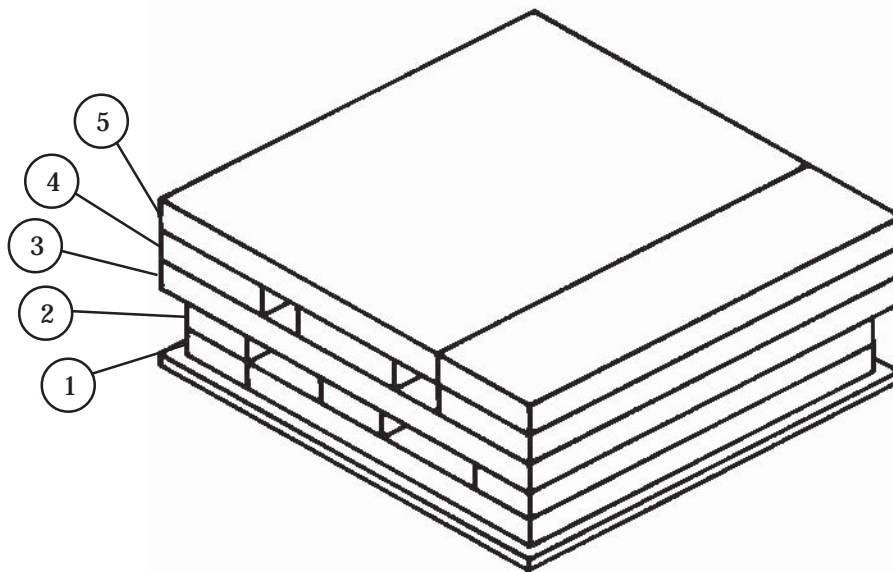
## RIGGING CONTAINER

9-16. Rig the container according to Paragraphs 9-5 through 9-9.

## INSTALLING PARACHUTE

9-17. Install the 26-foot high-velocity parachute according to Chapter 8.

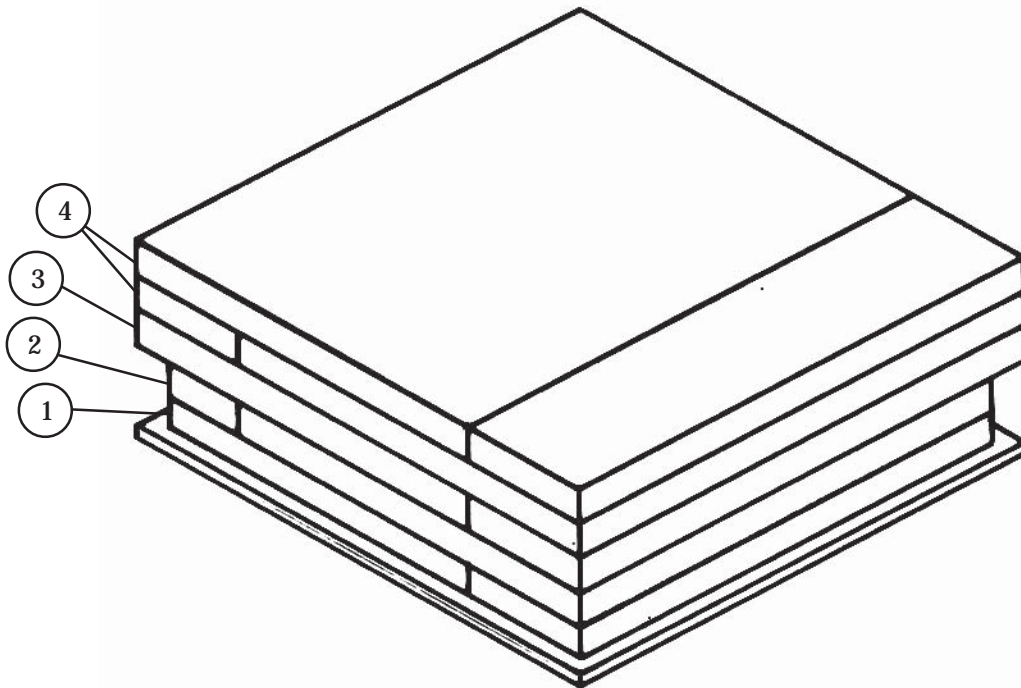
**NOTE:** This drawing is not drawn to scale.



- ① Center a 36- by 44-inch and an 8- by 44-inch piece of honeycomb side by side on the skid board. Make sure the layer is 2 inches in from all sides.
- ② Cut three 8- by 44-inch pieces of honeycomb. Center one piece on top of the first layer of honeycomb. Place one piece of honeycomb even with each side edge.
- ③ Center a 36- by 48-inch and a 12- by 48-inch piece of honeycomb side by side on top of the second layer of honeycomb.
- ④ Cut three 12- by 48-inch pieces of honeycomb. Center one piece on top of the third layer of honeycomb. Place one piece of honeycomb even with each side edge.
- ⑤ Repeat step 3 for the fifth layer of honeycomb.

**Figure 9-9. Honeycomb Positioned for Load Weighing Less than 1,100 Pounds**

**NOTE:** This drawing is not drawn to scale.



- ① Center a 36- by 44-inch and an 8- by 44-inch piece of honeycomb side by side on the skid board. Make sure the layer is 2 inches from all sides.
- ② Repeat step 1 and alternate the pieces of honeycomb from the second layer of honeycomb.
- ③ Center a 36- by 48-inch and a 12- by 48-inch piece of honeycomb side by side on top of the second layer of honeycomb.
- ④ Repeat step 3 and alternate the pieces of honeycomb for the fourth and fifth layers of honeycomb.

**Figure 9-10. Honeycomb Positioned for Load Weighing More than 1,100 Pounds**

## MARKING RIGGED LOAD

9-18. Mark the rigged load according to Chapter 1. Compute the rigged load data.

### CAUTION

Make the final rigger inspection required by FM 4-20.102/NAVSEA SS400-AB-MMO-010/TO 13C7-1-5 and AR 59-4/OPNAVINST 4630.24C/AFJ 13-210(I)/MCO 13480.1B before the load leaves the rigging site.



### RIGGING LOAD DATA (without parachute)

26-foot, high-velocity parachute .....501 - 1,100 pounds

**NOTE:** This container may weigh up to 2,200 pounds using the honeycomb stack formation given in Figure 9-10.

**Figure 9-11. A-22 Container Load Weighing Less than 1,100 Pounds Rigged for High-Velocity Airdrop**

**EQUIPMENT REQUIRED**

9-19. Use the equipment listed in Table 9-3 to rig the load shown in Figure 9-11.

**Table 9-3. Equipment Required for Rigging an A-22 Container Load Weighing Less Than 1,100 Pounds for High-Velocity Airdrop**

National Stock Number	Item	Quantity
8040-00-273-8713	Adhesive, paste, 1-gallon	As required
1670-00-587-3421	Bag, cargo, A-22	1
4030-00-678-8562	Clevis, suspension, 3/4-inch (medium)	1
4020-00-240-2146	Cord, nylon, type III	As required
1670-00-753-3928	Pad, energy-dissipating material, honeycomb	2 sheets
1670-00-872-6109	Parachute, high-velocity, 26-foot	1
5530-00-128-4981	Plywood: 3/4- by 48- by 96-inch (locally fabricated skid board) or 1- by 48- by 96-inch	1 sheet
5530-00-914-5118	Tape, masking, 2-inch	As required
7510-00-266-6710	Thread, cotton, ticket number 8/7	As required
8310-01-102-4478	Webbing: Cotton, 1/4-inch, type I	As required
8305-00-268-2411	Nylon, tubular, 1/2-inch	As required
8305-00-082-5752		As required

**SECTION III - RIGGING DOUBLE A-22 CARGO BAG LOADS FOR LOW-VELOCITY AIRDROP**

**DESCRIPTION OF LOAD**

9-20. A typical load is rigged for low-velocity airdrop using a double A-22 container. The double container is made by using two A-22 cargo bags. The cover is optional. The weight limitation of the load is 900 to 2,200 pounds, excluding the weight of the parachute. The load is rigged with one G-12E cargo parachute with a 68-inch diameter pilot parachute. See Chapter 2 for aircraft capabilities and limitations.

## PREPARING SKID BOARD

9-21. Prepare the skid board as shown in Figure 9-12.

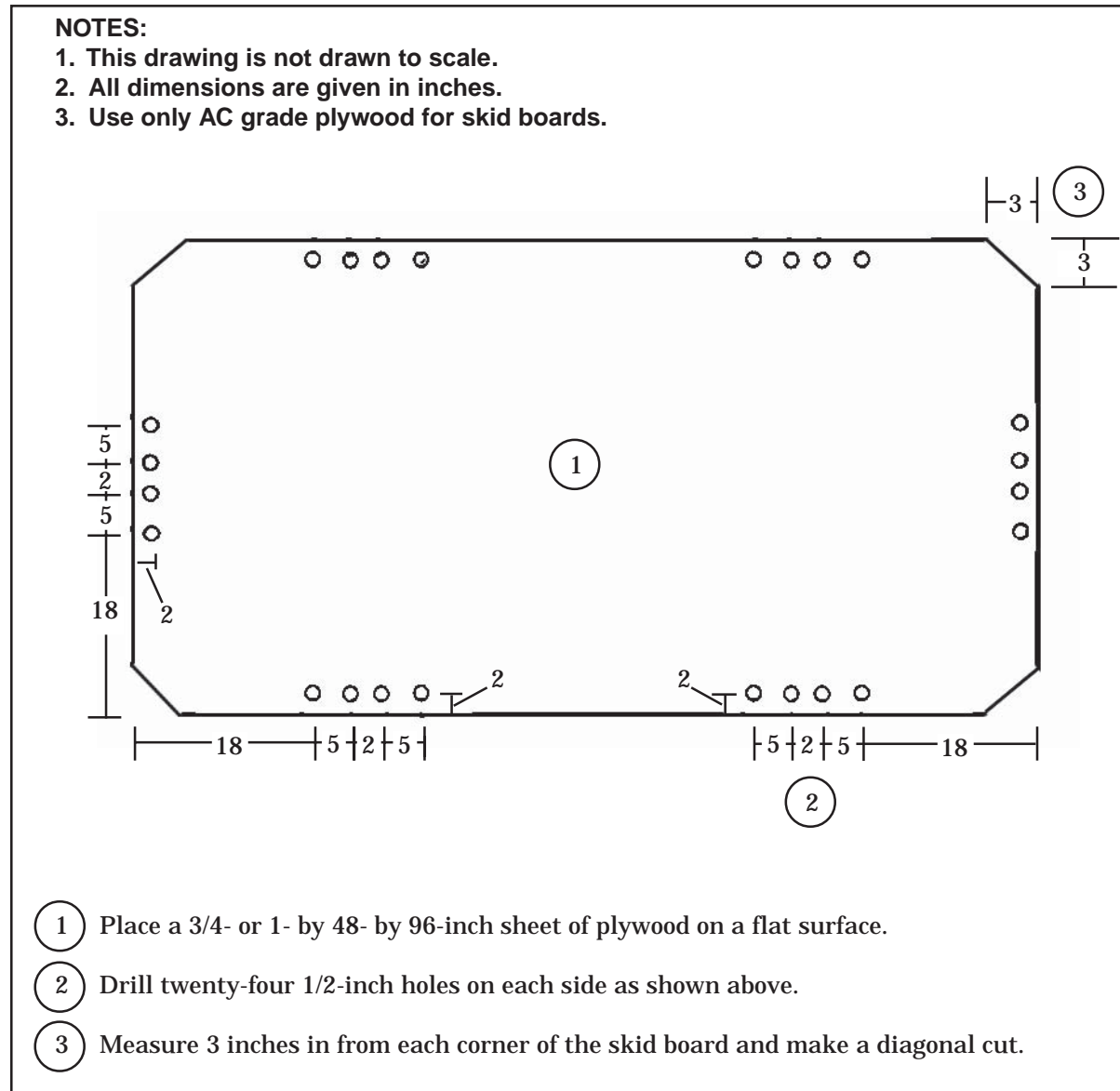


Figure 9-12. Skid Board Prepared for a Double A-22 Load

## PREPARING SKID BOARD TIES AND POSITIONING HONEYCOMB

9-22. Prepare the skid board ties and position the honeycomb on the skid board as shown in Figure 9-13.

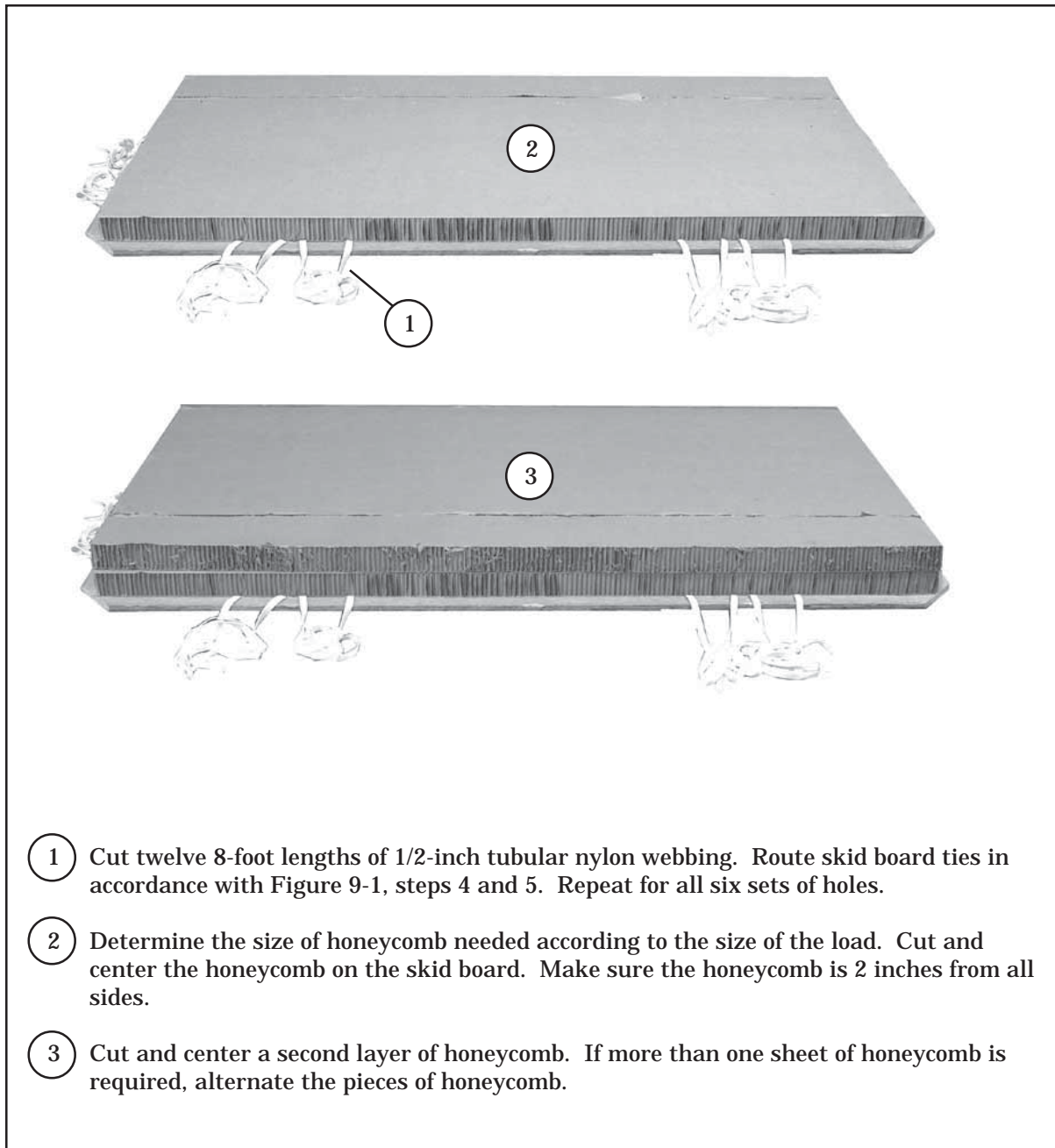


Figure 9-13. Skid Board Ties Prepared and Honeycomb Positioned

## POSITIONING A-22 SLING ASSEMBLIES

9-23. Position two A-22 sling assemblies on the double A-22 load as shown in Figure 9-14.

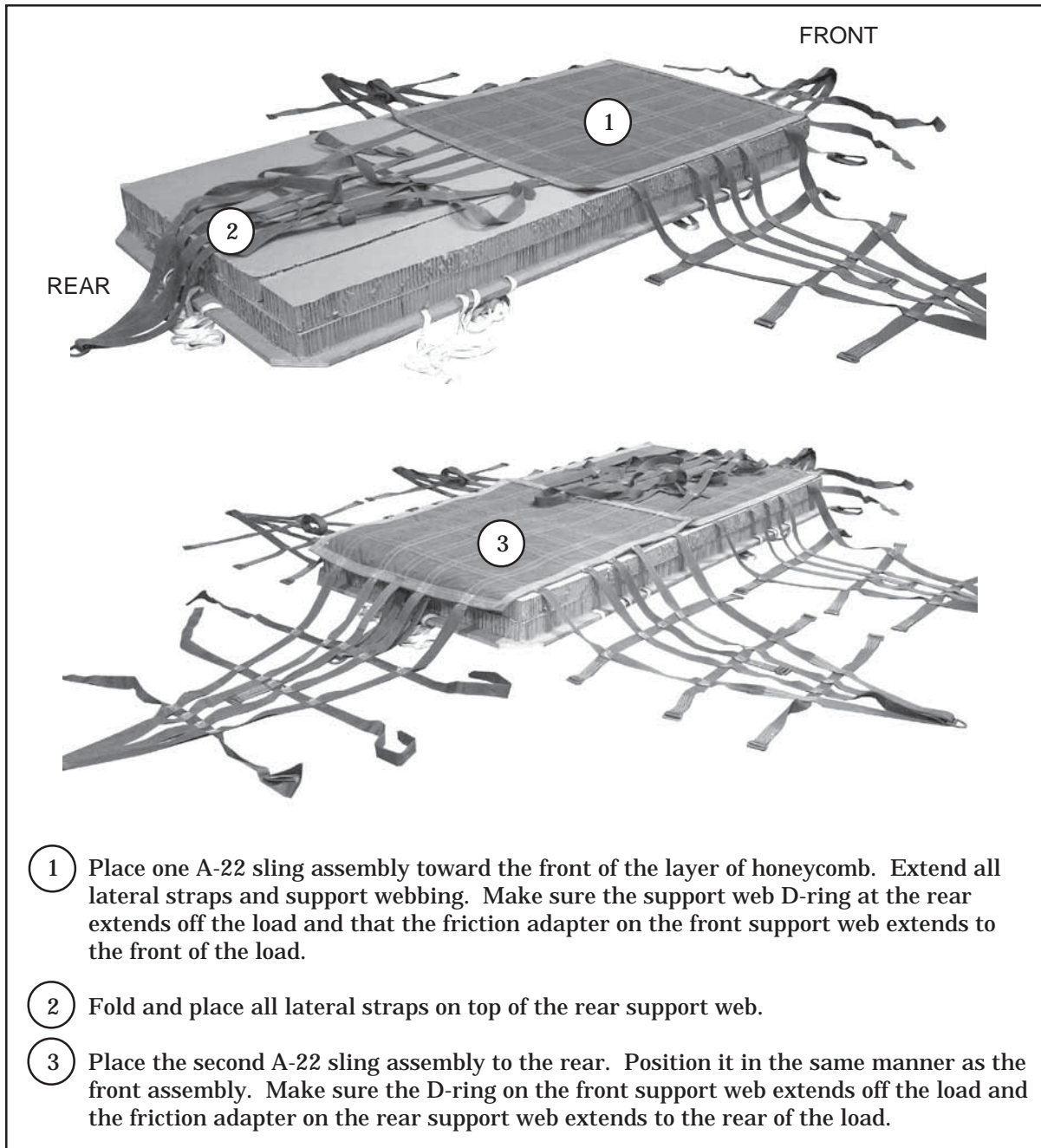


Figure 9-14. Sling Assemblies Positioned



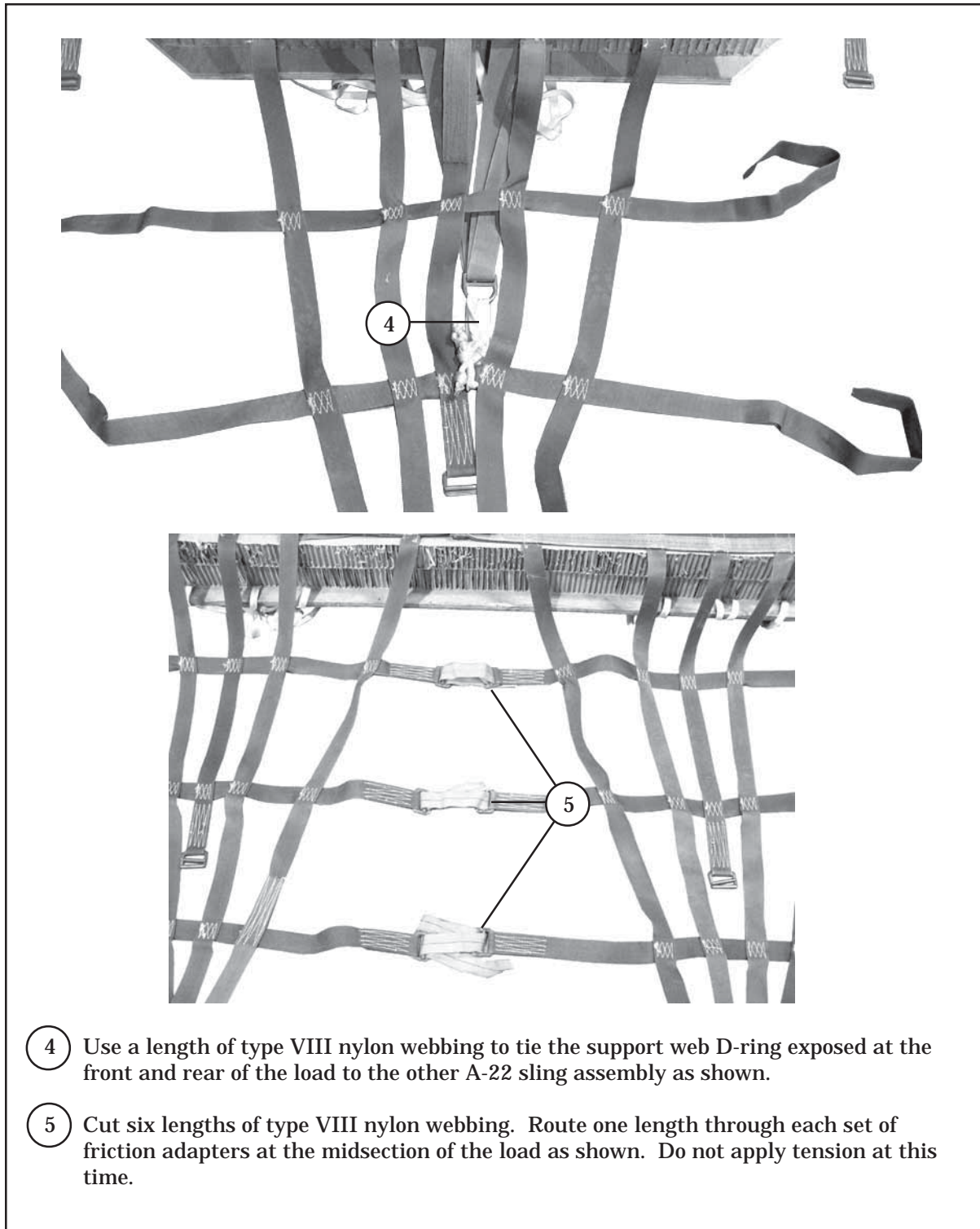


Figure 9-14. Sling Assemblies Positioned (Continued)

## POSITIONING COVERS

9-24. Use two A-22 cargo bag covers when rigging this load, if needed. Position the covers as shown in Figure 9-15.

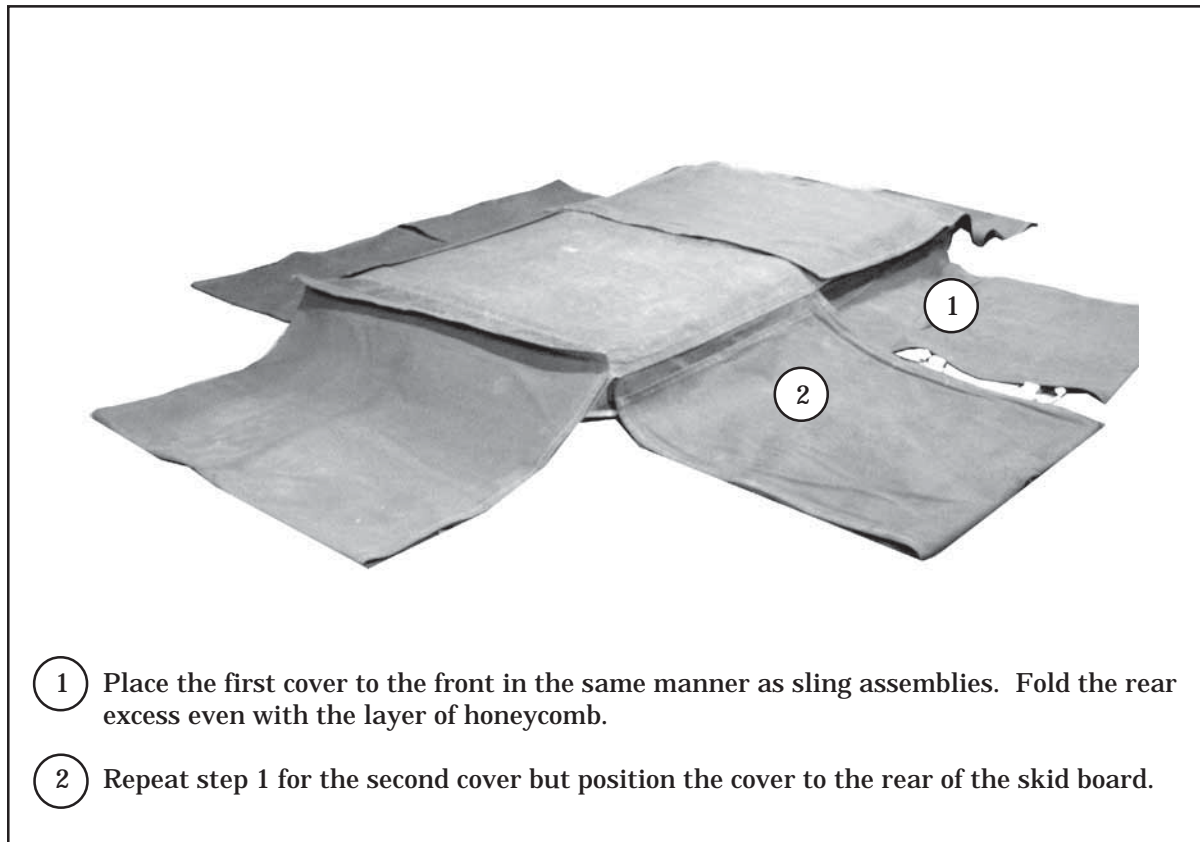


Figure 9-15. Covers Positioned

## POSITIONING LOAD AND CLOSING BAG COVERS

9-25. Center the load so that the weight of the load is evenly distributed. Use honeycomb and cellulose wadding to protect the items. Use cord, tape or steel strapping to keep the load from shifting. Close the bag as shown in Figure 9-16.

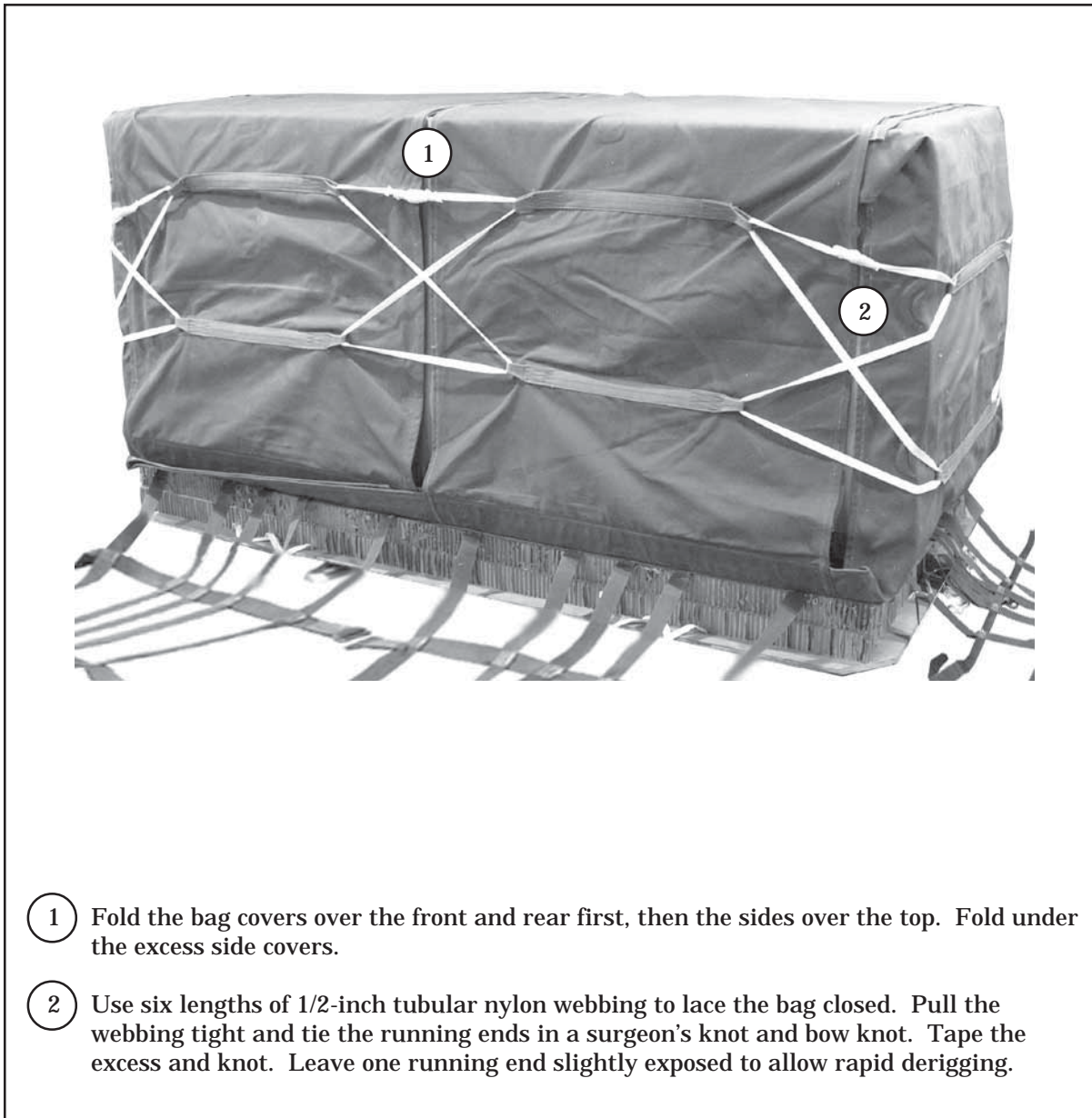


Figure 9-16. A-22 Cargo Bag Covers Closed

## SECURING TIE-DOWN STRAPS

9-26. Secure the tie-down straps as shown in Figure 9-17.

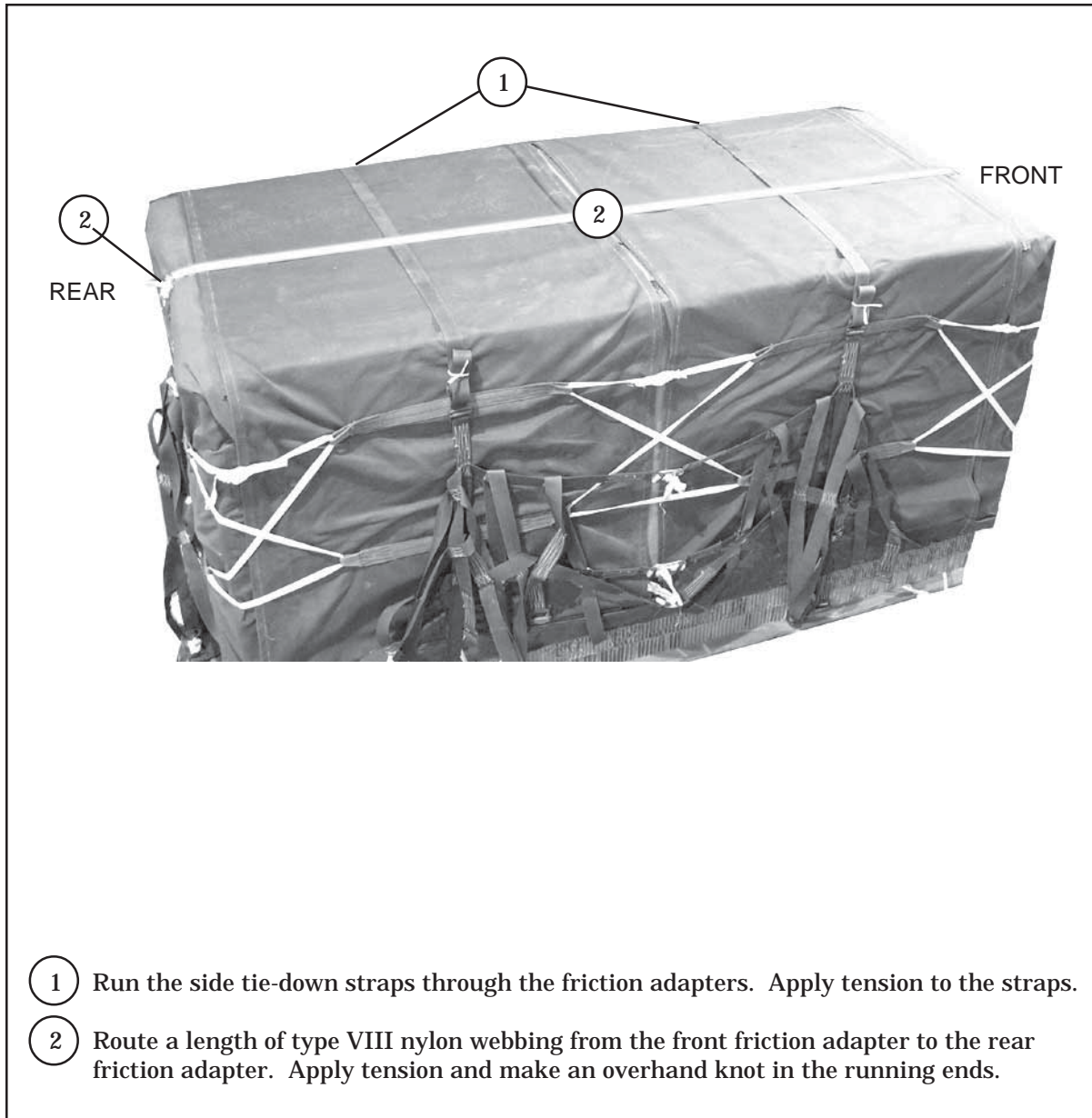


Figure 9-17. Tie-Down Straps Secured

## SECURING LATERAL STRAPS

9-27. Secure the lateral straps as shown in Figure 9-18.

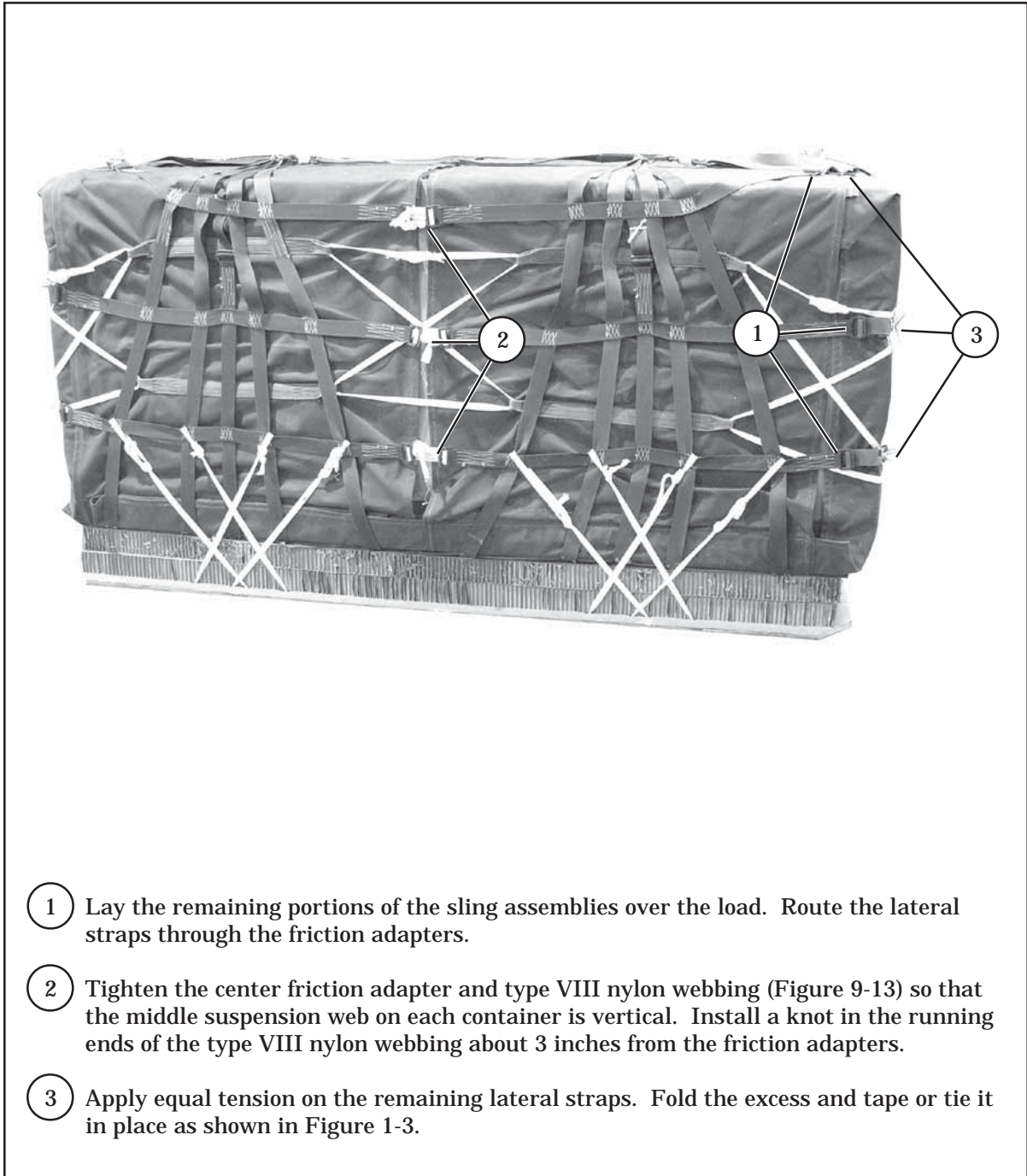
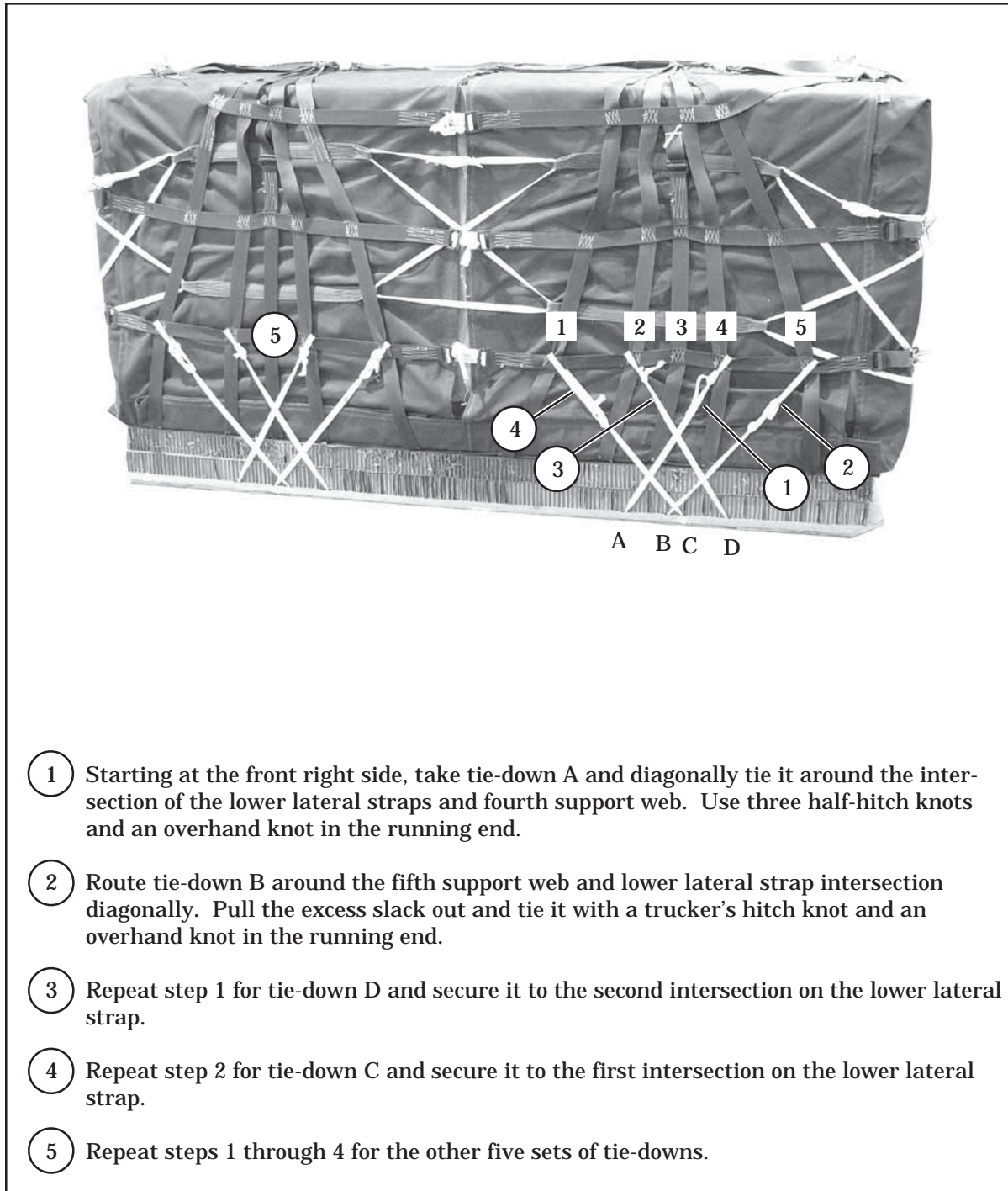


Figure 9-18. Lateral Straps Secured

## SECURING SKID BOARD TIES

9-28. Secure the skid board ties as shown in Figure 9-19.



- ① Starting at the front right side, take tie-down A and diagonally tie it around the intersection of the lower lateral straps and fourth support web. Use three half-hitch knots and an overhand knot in the running end.
- ② Route tie-down B around the fifth support web and lower lateral strap intersection diagonally. Pull the excess slack out and tie it with a trucker's hitch knot and an overhand knot in the running end.
- ③ Repeat step 1 for tie-down D and secure it to the second intersection on the lower lateral strap.
- ④ Repeat step 2 for tie-down C and secure it to the first intersection on the lower lateral strap.
- ⑤ Repeat steps 1 through 4 for the other five sets of tie-downs.

Figure 9-19. Skid Board Ties Secured

## INSTALLING SUSPENSION SLINGS

9-29. Install suspension slings using six suspension webs, two 3/4-inch cargo suspension clevises, and two 3-foot (2-loop), type XXVI nylon webbing slings as shown in Figure 9-20.

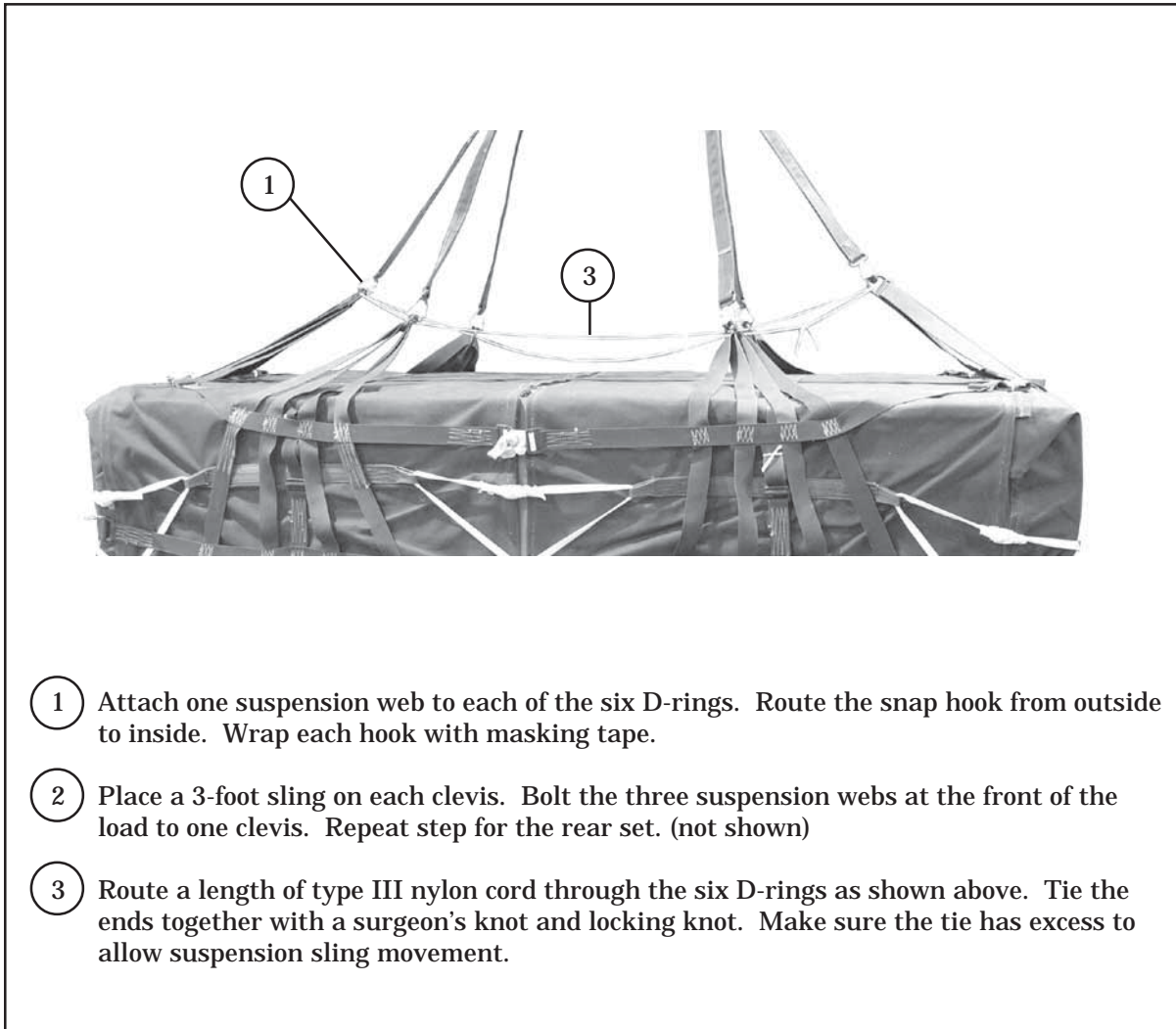


Figure 9-20. Suspension Slings Installed

## INSTALLING PARACHUTE

9-30. Install a G-12E cargo parachute as shown in Figure 9-21.

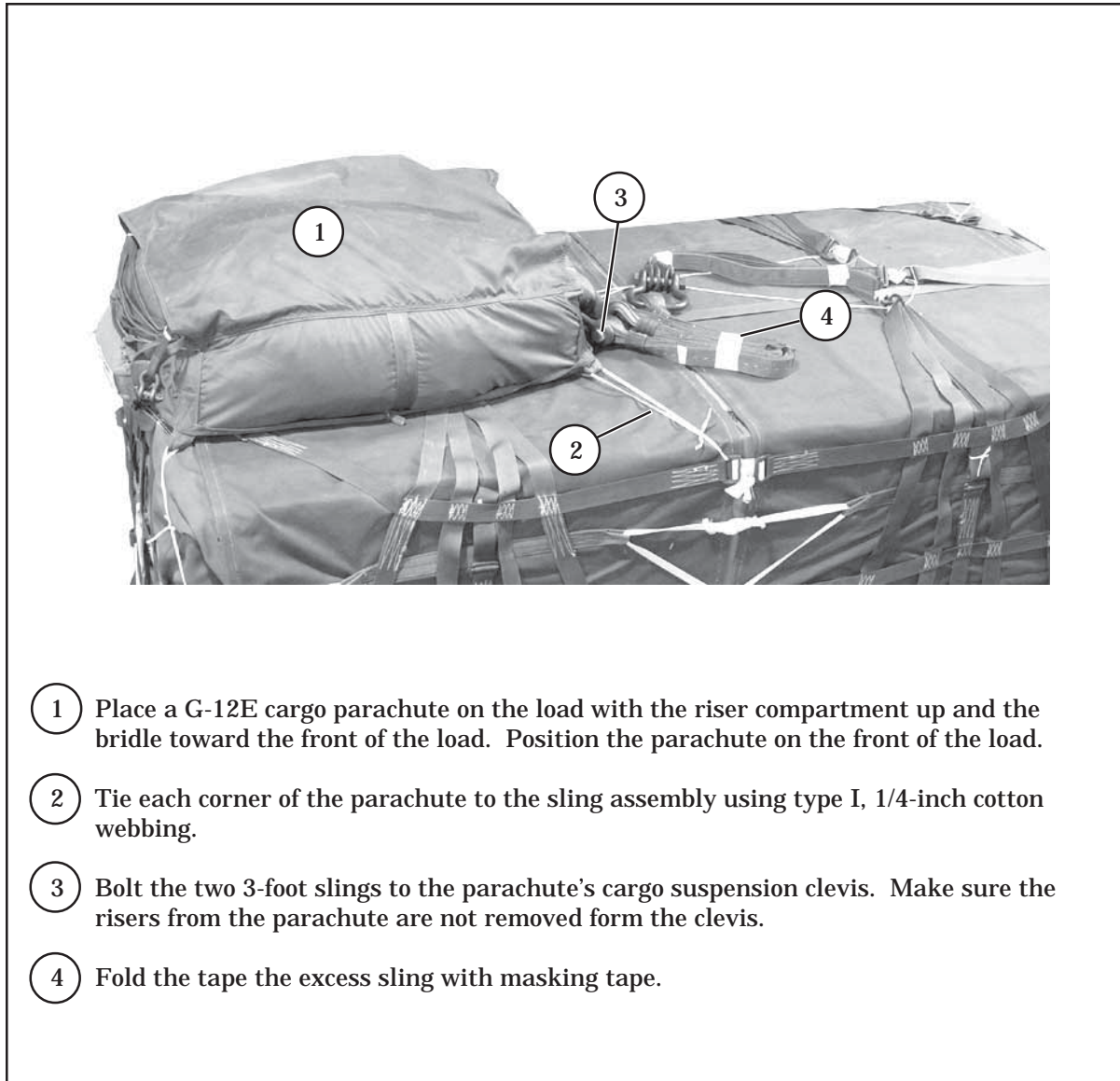


Figure 9-21. G-12E Cargo Parachute Installed

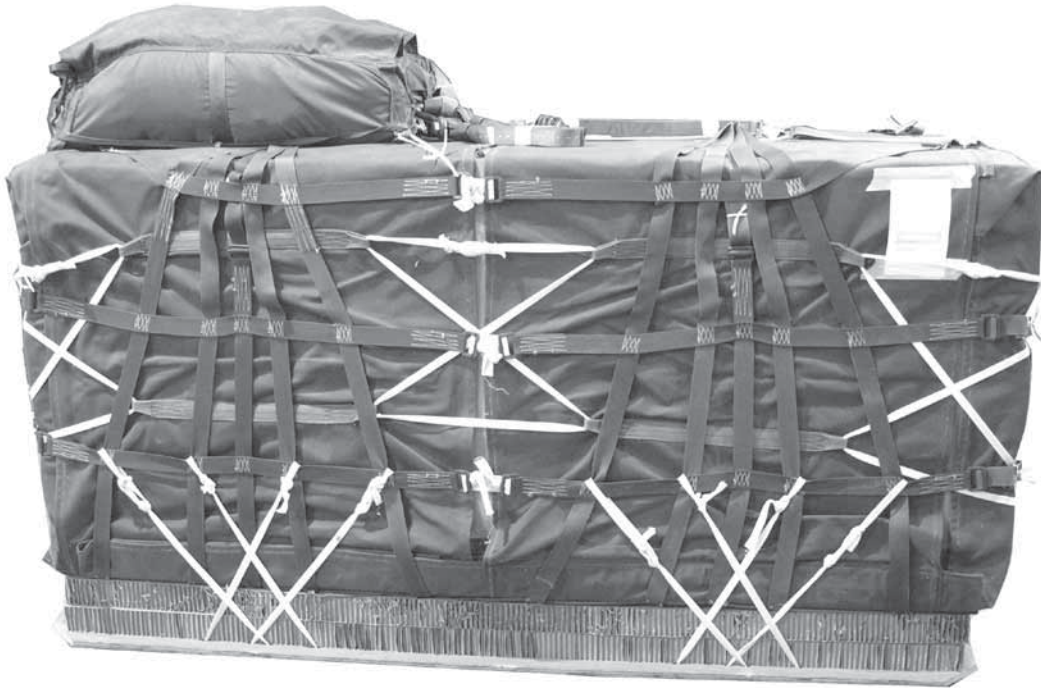


## MARKING RIGGED LOAD

9-31. Mark the rigged load according to Paragraph 1-5. Compute the rigged load data.

### CAUTION

Make the final rigger inspection required by FM 4-20.102/NAVSEA SS400-AB-MMO-010/TO 13C7-1-5 and AR 59-4/OPNAVINST 4630.24C/AFJ 13-210(I)/MCO 13480.1B before the load leaves the rigging site.



### RIGGING LOAD DATA (without parachute)

G-12E cargo parachute ..... 900 - 2,200 pounds

Figure 9-22. Double A-22 Cargo Bag Rigged for Low-Velocity Airdrop

## EQUIPMENT REQUIRED

9-32. Use the equipment listed in Table 9-4 to rig the load shown in Figure 9-22.

**Table 9-4. Equipment Required for Rigging Double A-22 Cargo Bag for Low-Velocity Airdrop**

National Stock Number	Item	Quantity
1670-00-587-3421	Bag, cargo, A-22	2
4030-00-678-8562	Clevis, suspension, 3/4-inch (medium)	2
4020-00-240-2146	Cord, nylon, type III	As required
1670-00-753-3928	Pad, energy-dissipating material, honeycomb Parachute	As required
1670-01-065-3755	Cargo, G-12E	1
1670-00-216-7297	Pilot, 68-inch diameter	1
5530-00-128-4981	Plywood: 3/4- by 48- by 96-inch (locally fabricated skid board) or	1 sheet
5530-00-914-5118	1- by 48- by 96-inch	1 sheet
1670-01-062-6301	Sling, cargo, airdrop, 3-foot (2-loop), type XXVI nylon webbing	2
1670-00-368-7486	Strap, webbing, restraint (shear strap), 60-inch	1
7510-00-266-6710	Tape, masking, 2-inch	As required
8310-01-102-4478	Thread, cotton, ticket number 8/7	As required
8305-00-268-2411	Webbing: Cotton, 1/4-inch, type I	As required
8305-00-082-5752	Nylon: Tubular, 1/2-inch	As required
8305-00-263-3591	Type VIII, NT	As required

## SECTION IV - RIGGING STRETCH A-22 CARGO BAG LOADS FOR LOW-VELOCITY AIRDROP

### DESCRIPTION OF LOAD

9-33. A typical load is rigged for low-velocity airdrop using a stretch A-22 container. The stretch container is made by using two A-22 cargo bags. The cover is optional. The weight limitation of the load is 675 to 2,200 pounds, excluding the weight of the parachute. The load is rigged with one G-12E cargo parachute with a 68-inch diameter pilot parachute. See Chapter 2 for aircraft capabilities and limitations.

## PREPARING SKID BOARD

9-34. Prepare a skid board as shown in Figure 9-23.

## PREPARING SKID BOARD TIES AND POSITIONING HONEYCOMB

9-35. Prepare skid board ties and position the honeycomb on the skid board as shown in Figure 9-13.

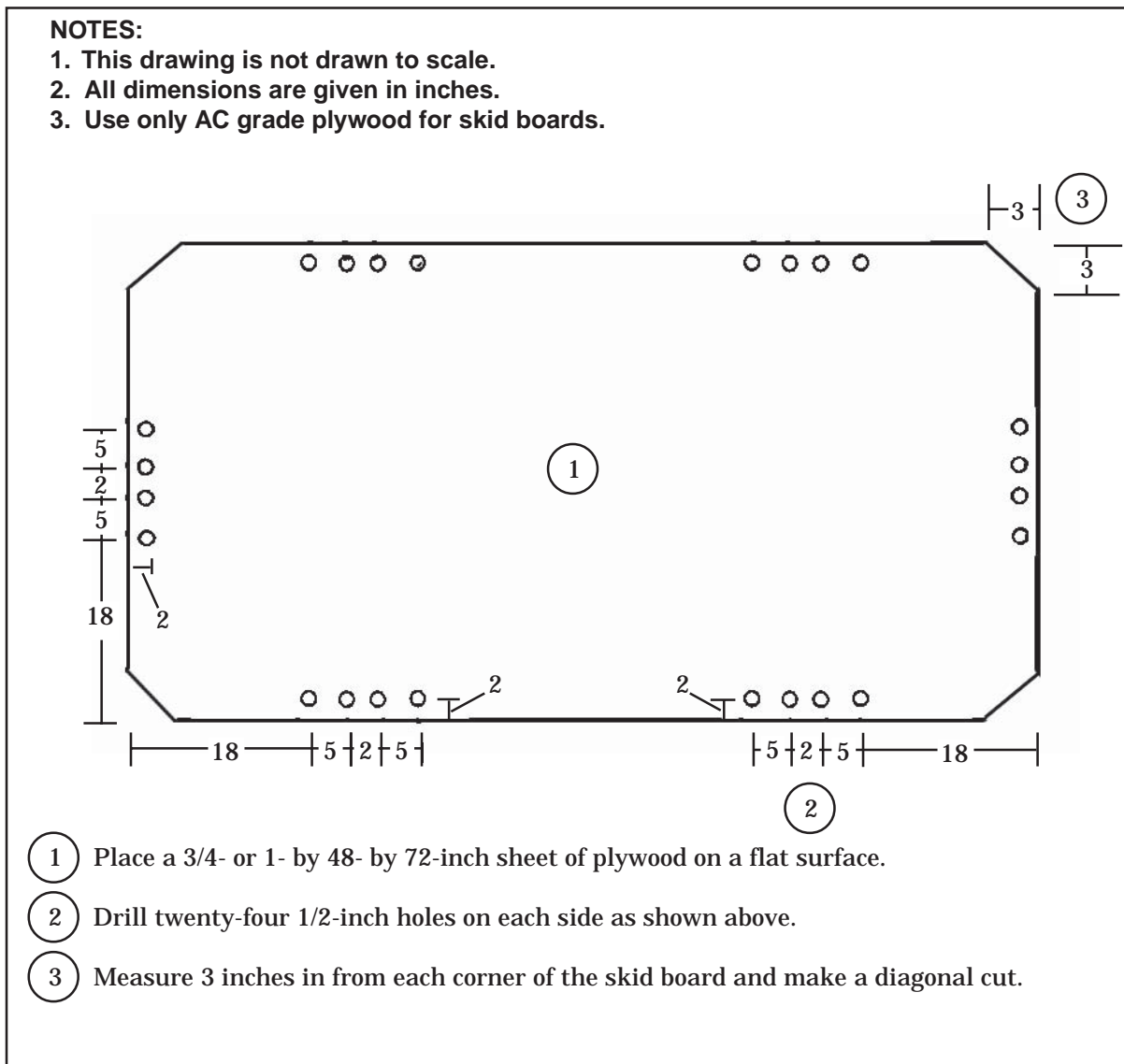


Figure 9-23. Skid Board Prepared for a Stretch A-22 Load

## POSITIONING A-22 SLING ASSEMBLIES

9-36. Position two A-22 sling assemblies on the stretch A-22 load as shown in Figure 9-24.

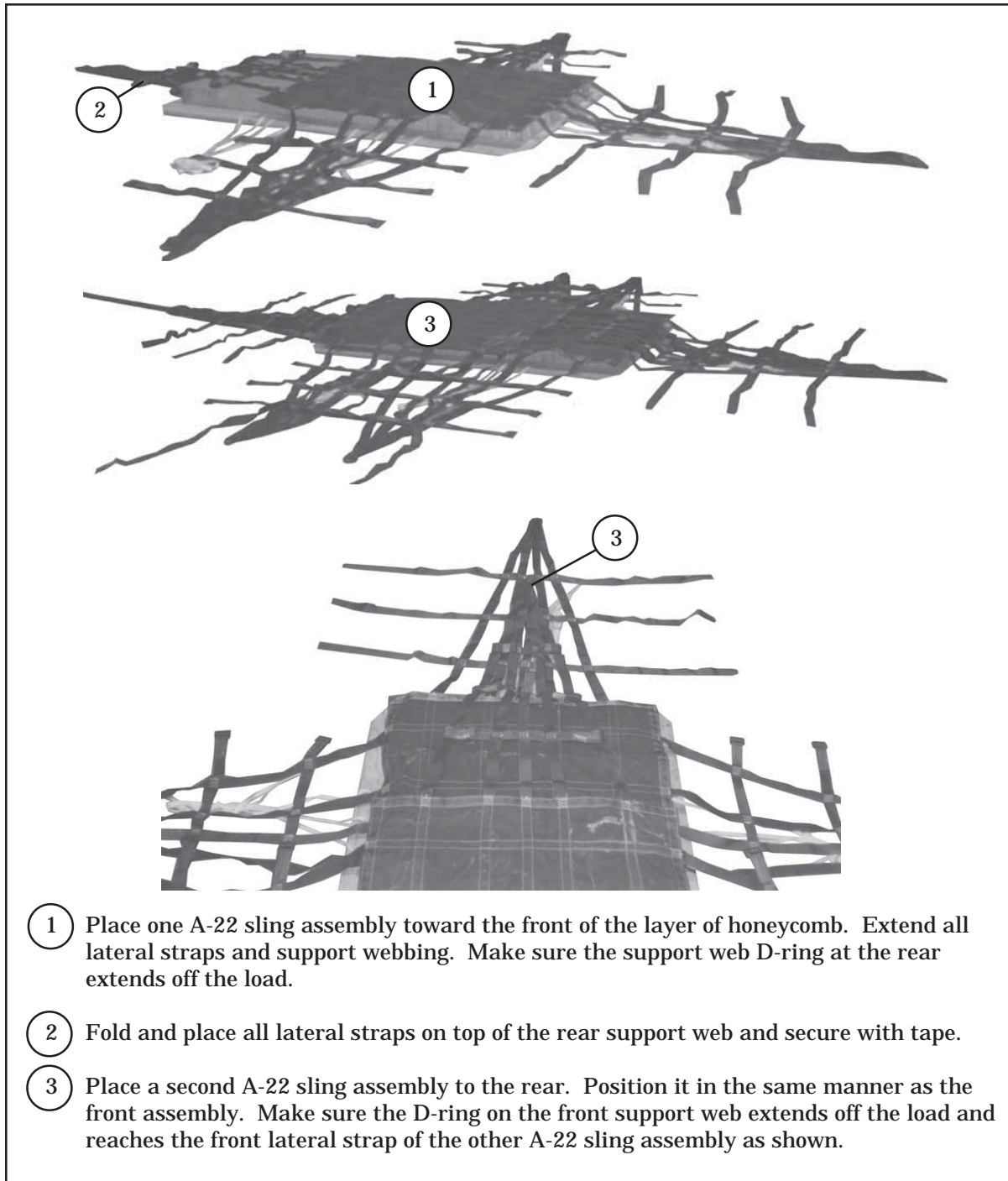
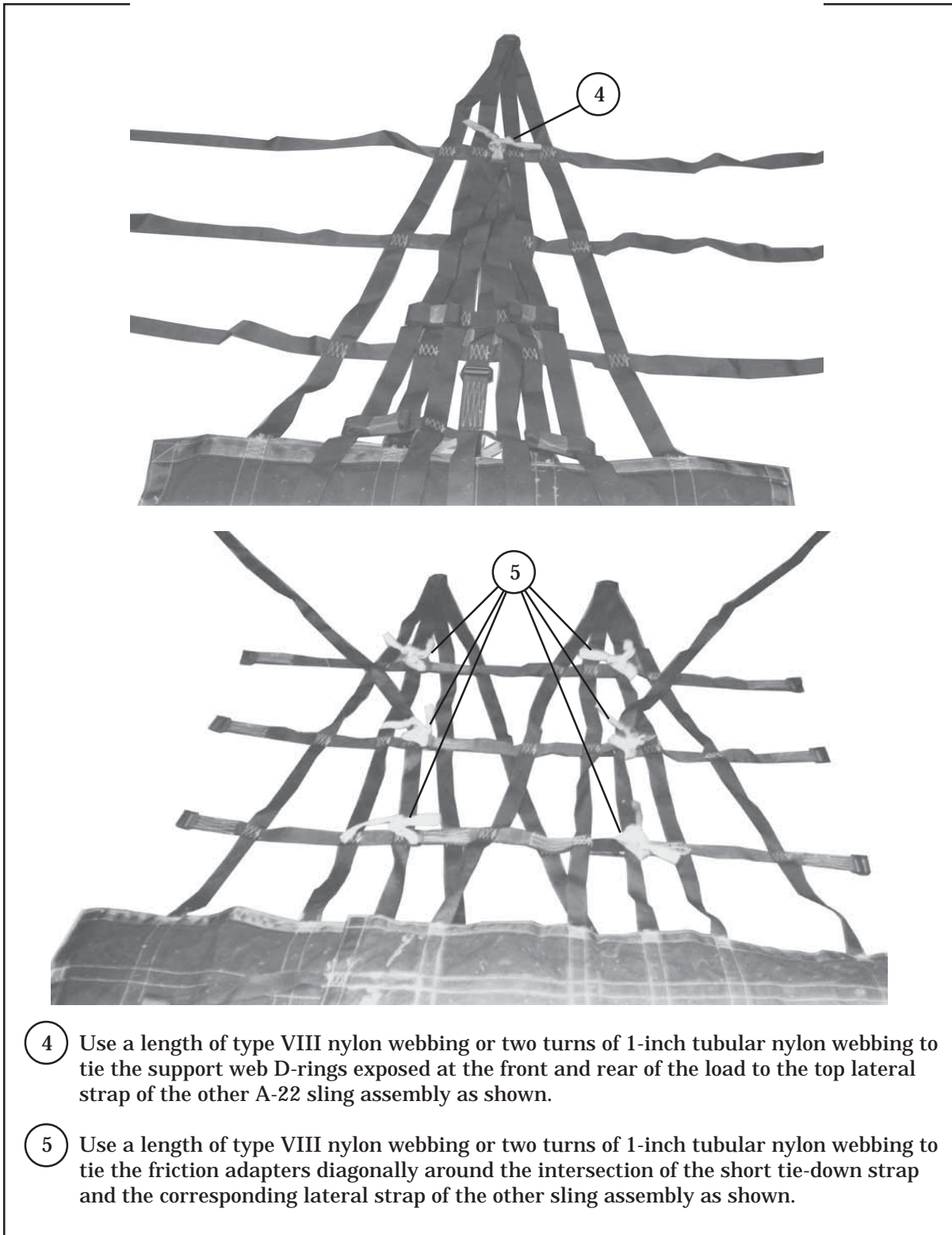


Figure 9-24. A-22 Sling Assemblies Positioned



- ④ Use a length of type VIII nylon webbing or two turns of 1-inch tubular nylon webbing to tie the support web D-rings exposed at the front and rear of the load to the top lateral strap of the other A-22 sling assembly as shown.
- ⑤ Use a length of type VIII nylon webbing or two turns of 1-inch tubular nylon webbing to tie the friction adapters diagonally around the intersection of the short tie-down strap and the corresponding lateral strap of the other sling assembly as shown.

Figure 9-24. A-22 Sling Assemblies Positioned (Continued)

## POSITIONING COVERS

9-37. Use two A-22 cargo bag covers when rigging this load, if needed. Position the covers as shown in Figure 9-25.

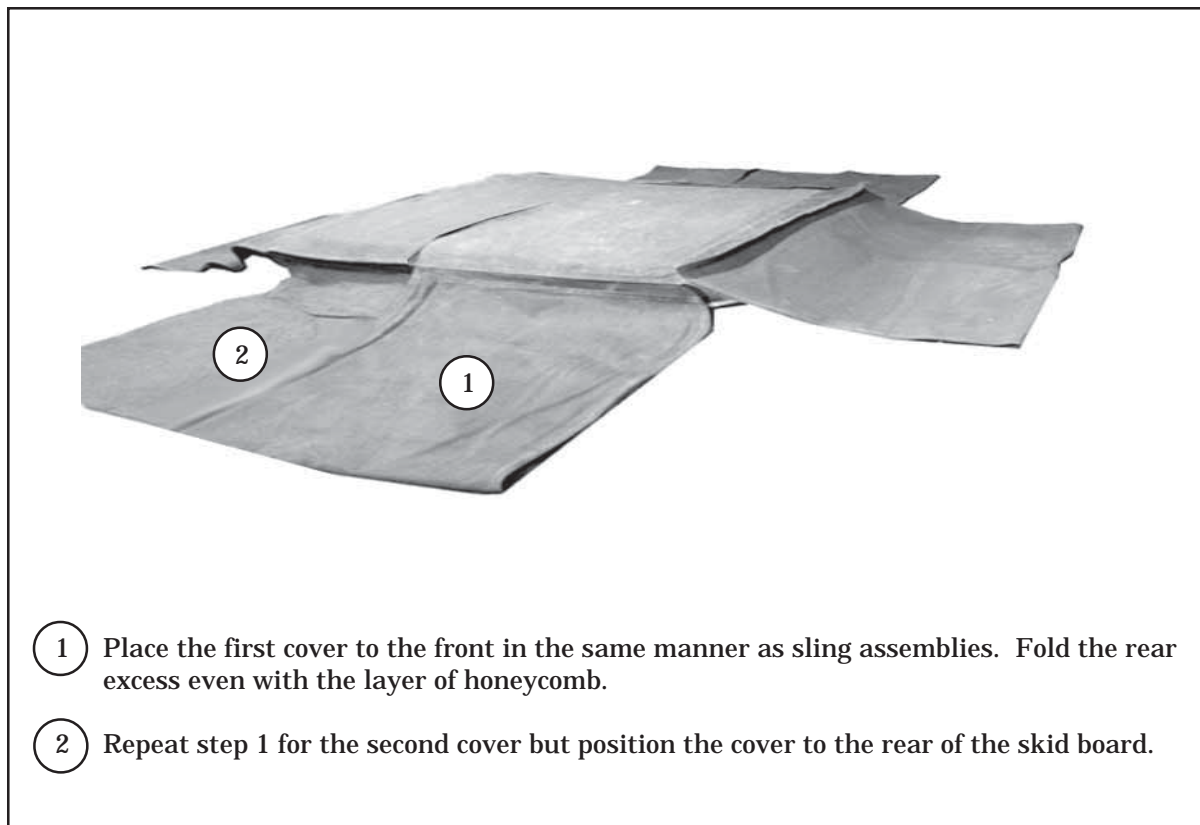


Figure 9-25. Covers Positioned

## POSITIONING LOAD AND CLOSING BAG COVERS

9-38. Center the load so that the weight of the load is evenly distributed. Use honeycomb and cellulose wadding to protect the items. Use cord, rope or steel strapping to keep the load from shifting. Close the bag as shown in Figure 9-26.

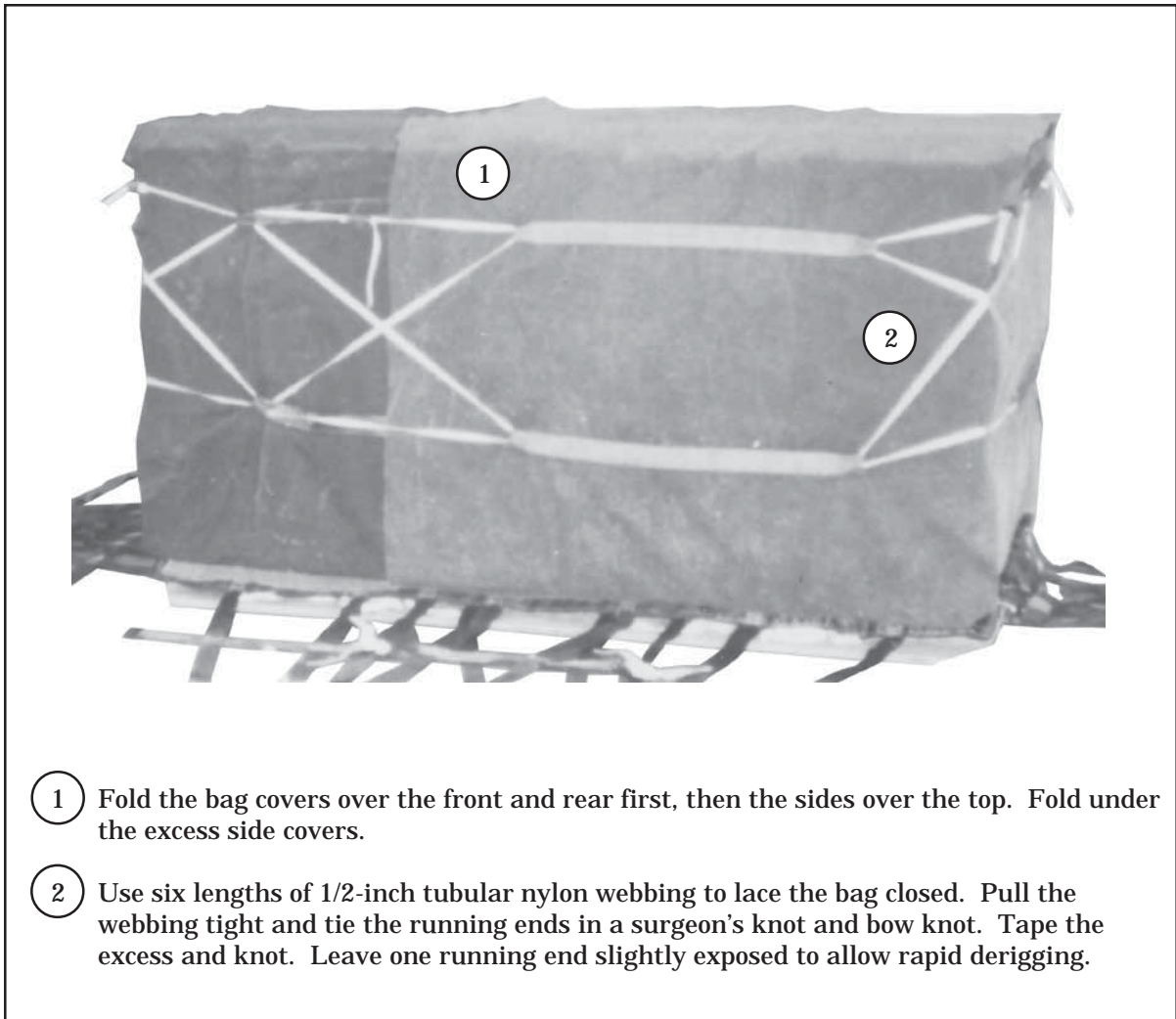


Figure 9-26. A-22 Cargo Bag Covers Closed

## SECURING TIE-DOWN STRAPS

9-39. Secure the tie-down straps as shown in Figure 9-27.

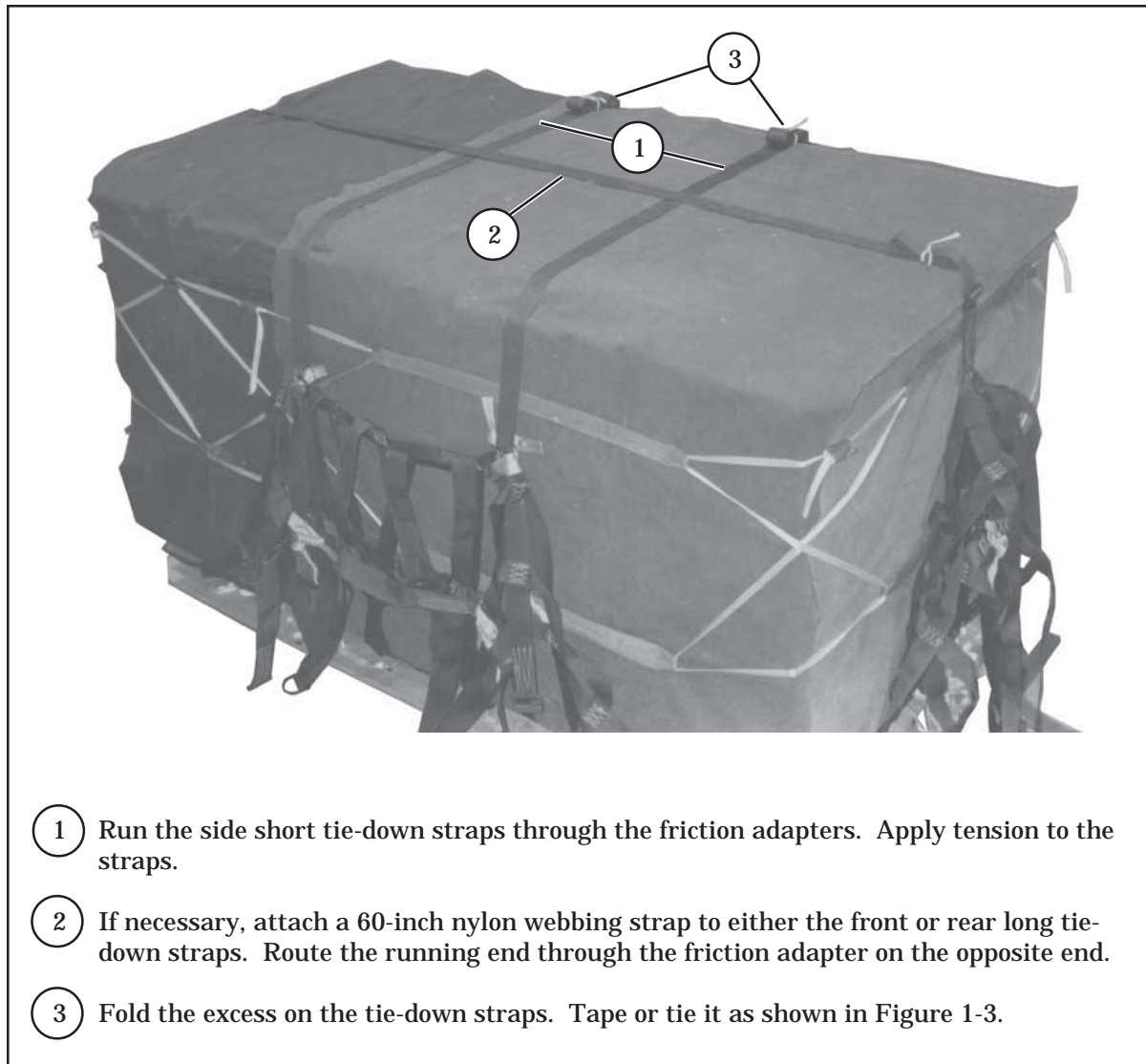
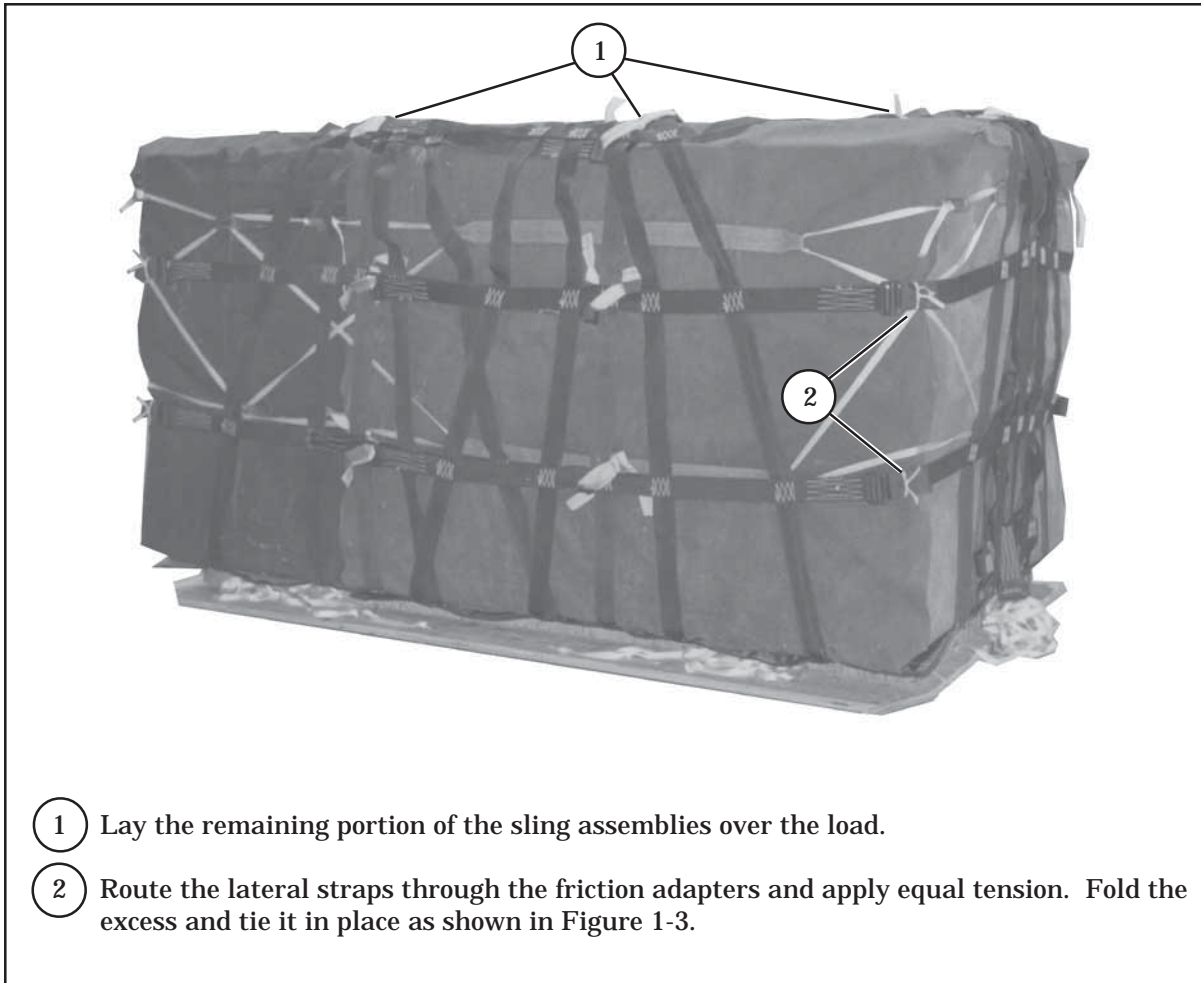


Figure 9-27. Tie-down Straps Secured



## SECURING LATERAL STRAPS

9-40. Secure the lateral straps as shown in Figure 9-28.



**Figure 9-28. Lateral Straps Secured**

## SECURING SKID BOARD TIES

9-41. Secure the skid board ties as shown in Figure 9-29.

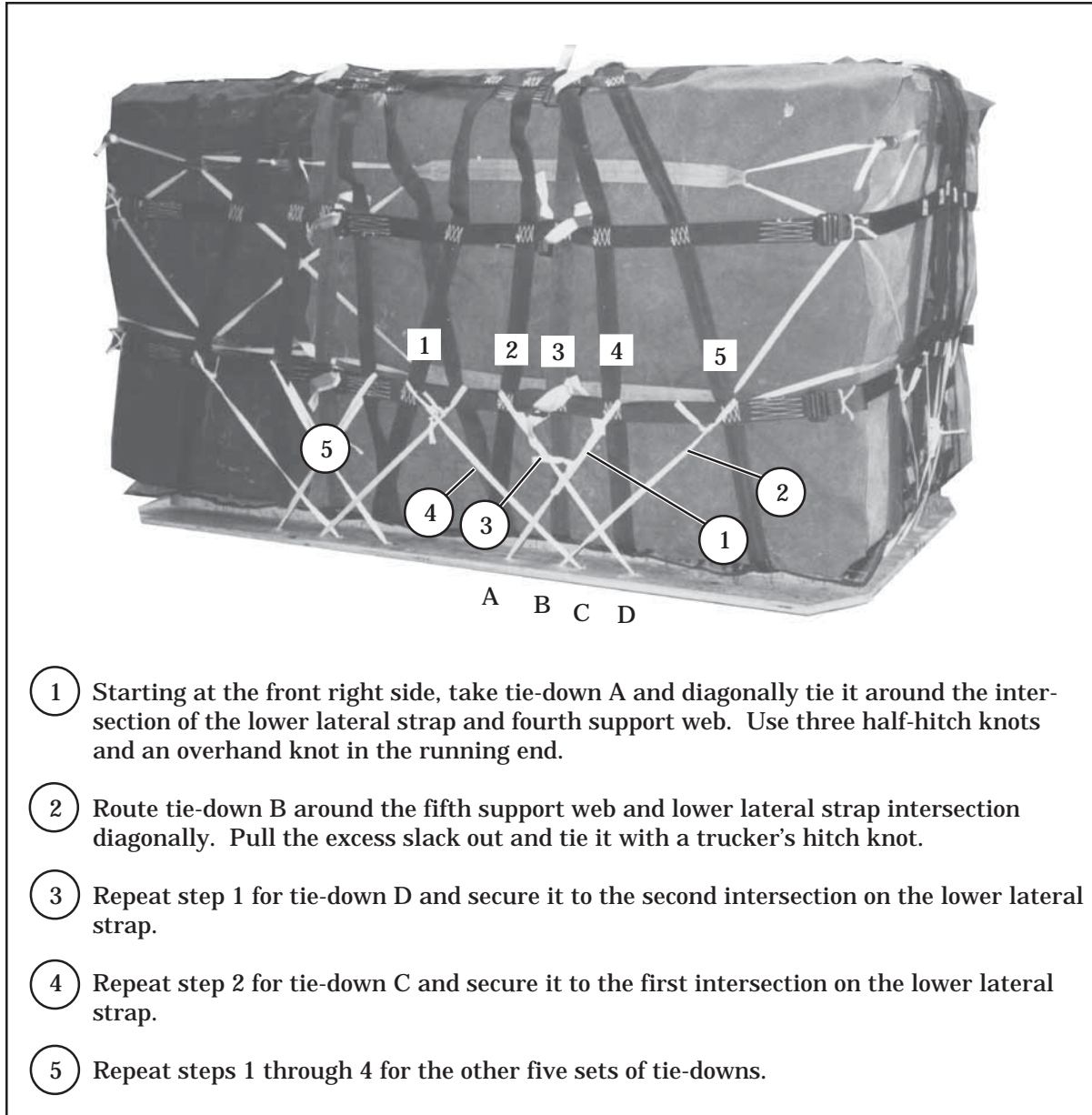
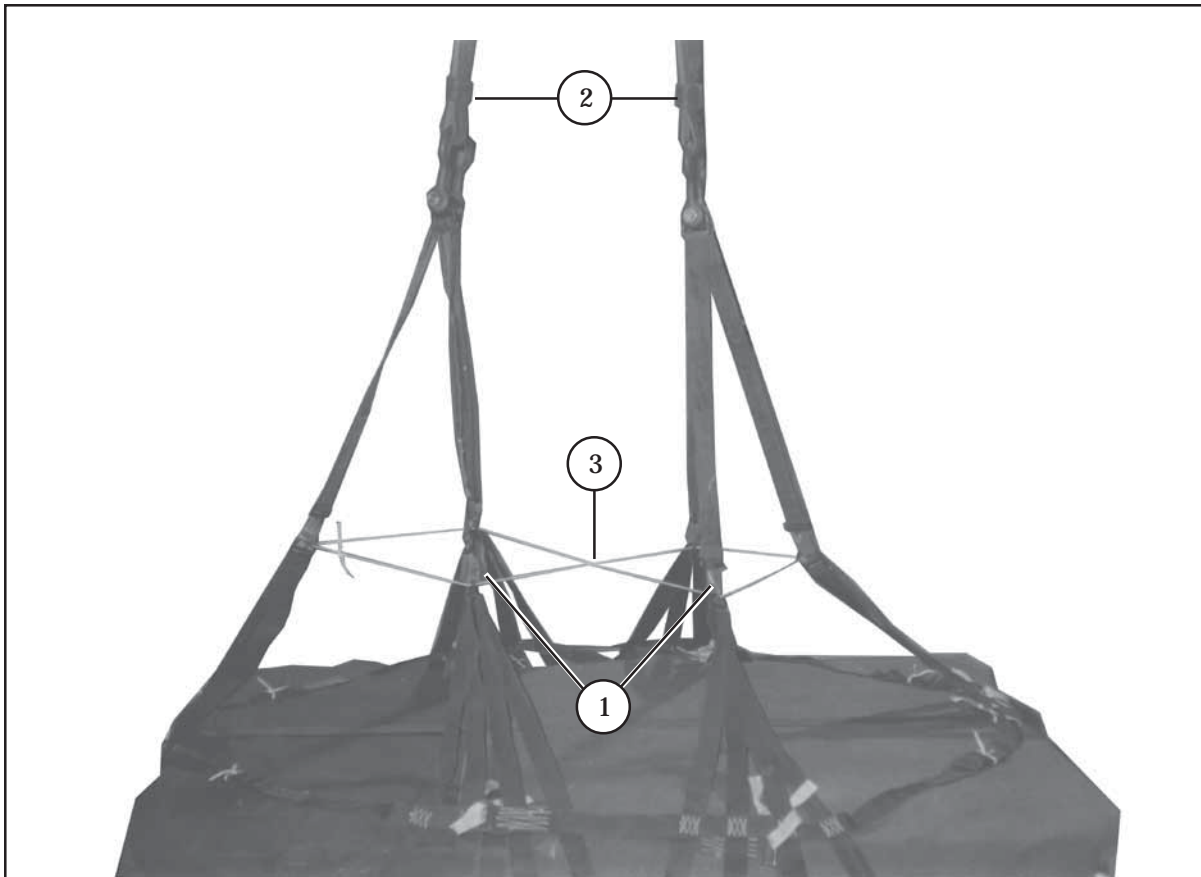


Figure 9-29. Skid Board Ties Secured

## INSTALLING SUSPENSION SLINGS

9-42. Install suspension slings using six suspension webs, two 3/4-inch cargo suspension clevises, and two 3-foot (2-loop), type XXVI nylon webbing slings as shown in Figure 9-30.



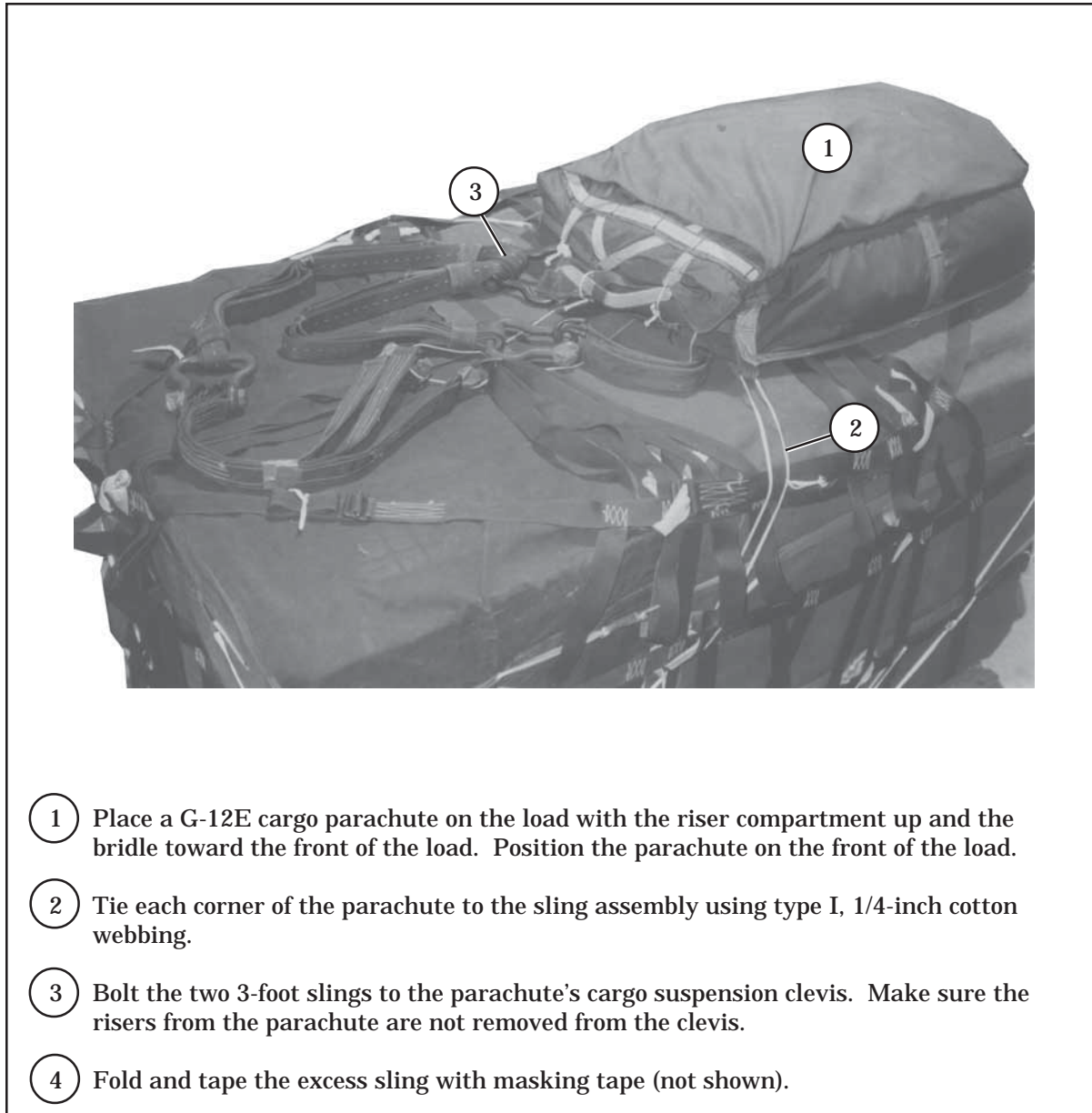
- ① Attach one suspension web to each of the six D-rings. Route the snap hook from outside to inside. Wrap each hook with masking tape.
- ② Place a 3-foot sling on each clevis. Bolt the three suspension webs at the front of the load to one clevis. Repeat step for the rear set.
- ③ Route a length of type III nylon cord through the six D-rings as shown above. Tie the ends together. Make sure the tie has excess to allow suspension sling movement.

**NOTE:** After positioning the type III nylon cord, fold and tape the excess with masking tape (not shown).

Figure 9-30. Suspension Slings Installed

## INSTALLING PARACHUTE

9-43. Install a G-12E cargo parachute as shown in Figure 9-31.



**Figure 9-31. G-12E Cargo Parachute Installed**

## MARKING RIGGED LOAD

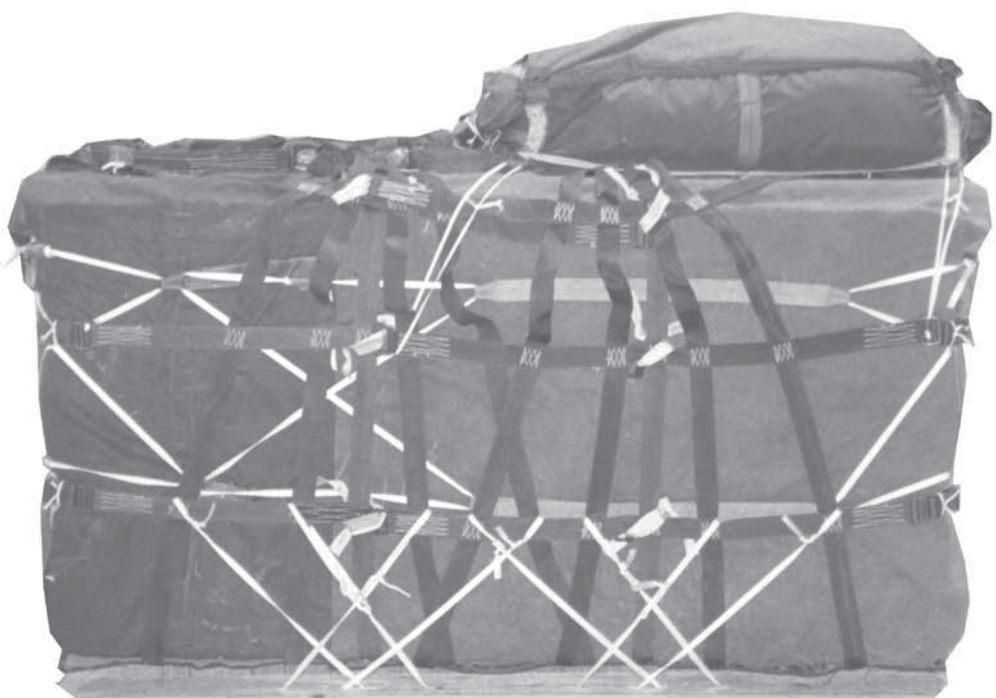
9-44. Mark the rigged load according to Chapter 1. Compute the rigged load data.

## EQUIPMENT REQUIRED

9-45. Use the equipment listed in Table 9-5 to rig the load shown in Figure 9-33.

**CAUTION**

Make the final rigger inspection required by FM 4-20.102/NAVSEA SS400-AB-MMO-010/TO 13C7-1-5 and AR 59-4/OPNAVINST 4630.24C/AFJ 13-210(I)/MCO 13480.1B before the load leaves the rigging site.



**RIGGING LOAD DATA (without parachute)**

G-12E cargo parachute .....	675 - 2,200 pounds
-----------------------------	--------------------

Figure 9-32. Stretch A-22 Cargo Bag Rigged for Low-Velocity Airdrop

**Table 9-5. Equipment for Rigging Stretch A-22 Cargo Bag for Low-Velocity Airdrop**

National Stock Number	Item	Quantity
1670-00-587-3421	Bag, cargo, A-22	2
4030-00-678-8562	Clevis, suspension, 3/4-inch (medium)	2
4020-00-240-2146	Cord, nylon, type III	As required
1670-00-753-3928	Pad, energy-dissipating material, honeycomb Parachute	As required
1670-01-065-3755	Cargo, G-12E	1
1670-00-216-7297	Pilot, 68-inch diameter	1
5530-00-128-4981	Plywood: 3/4- by 48- by 96-inch (locally fabricated skid board) or	1 sheet
5530-00-914-5118	1- by 48- by 96-inch	1 sheet
1670-01-062-6301	Sling, cargo, airdrop, 3-foot (2-loop), type XXVI nylon webbing	2
1670-00-368-7486	Strap, webbing, restraint (shear strap), 60-inch	1
7510-00-266-6710	Tape, masking, 2-inch	As required
8310-01-102-4478	Thread, cotton, ticket number 8/7	As required
8305-00-268-2411	Webbing: Cotton, 1/4-inch, type I	As required
8305-00-082-5752	Nylon: Tubular, 1/2-inch	As required
8305-00-263-3591	Type VIII, NT	As required
8305-00-268-2455	or Tubular, 1-in, OD	As required

## Chapter 10

# Rigging Petroleum Products

### CAUTION

Make sure all petroleum products are packaged in POP standard drums and cans.

## DESCRIPTION OF LOAD

10-1. This chapter shows how to rig sample loads of petroleum products. They will be rigged in an A-22 cargo bag. This chapter will show how to position the load only. The container is rigged as a typical A-22 load and the parachute is installed by normal procedures.

## PREPARING SKID BOARD AND POSITIONING HONEYCOMB

10-2. Prepare the skid board and position the honeycomb according to Chapter 9.

## POSITIONING CONTAINER

10-3. Center the sling assembly on the honeycomb stack. If desired, a cover may be used.

## POSITIONING LOAD

10-4. Position the load as follows:

- a. Use Figure 10-1 to position cases of oil.
- b. Use Figure 10-2 to position 5-gallon drums.
- c. Use Figure 10-3 to position 5-gallon fuel cans.
- d. Use Figure 10-4 to position 30-gallon grease drums and cases of oil.
- e. Use Figure 10-5 to position 55-gallon drums.

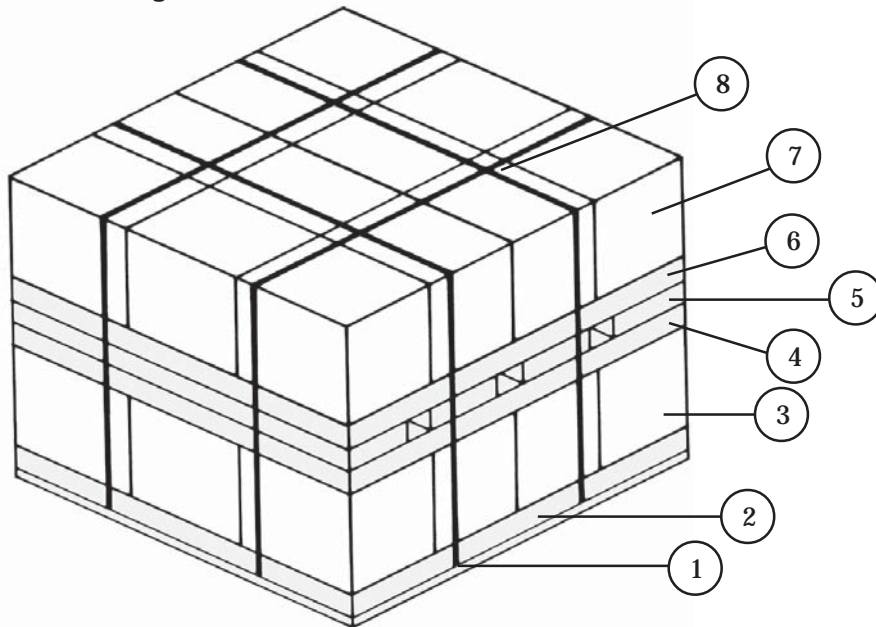
### NOTES:

1. These procedures can be used to rig similar loads.
2. The load may consist of drums of oil, grease, fuel, or a combination.

## SECURING CONTAINER AND INSTALLING PARACHUTE

10-5. Secure the container according to Figures 9-4 through 9-7. Install a G-12E cargo parachute according to Chapter 8.

**NOTE:** This drawing is not drawn to scale.



- ① Use four 20-foot lengths of steel strapping. Lay two lengths side to side on top of the container. Lay the other two lengths front to rear on top of the container. Adjust each length so that it is 8 inches from the edge.
- ② Center a 36- by 48-inch and a 12- by 48-inch piece of honeycomb side by side on top of the container.
- ③ Place 12 cases of oil on top of the honeycomb.
- ④ Form the second layer of honeycomb as described in step 2 except alternate the pieces of honeycomb.
- ⑤ Evenly space four 8- by 48-inch pieces of honeycomb on top of the second layer of honeycomb.
- ⑥ Form the fourth layer of honeycomb as described in step 2 except alternate the pieces of honeycomb.
- ⑦ Position 12 cases of oil on top of the honeycomb.
- ⑧ Bind the steel strapping over the top of the load. Use four seals to secure each piece of steel strapping. Cut off excess if necessary.

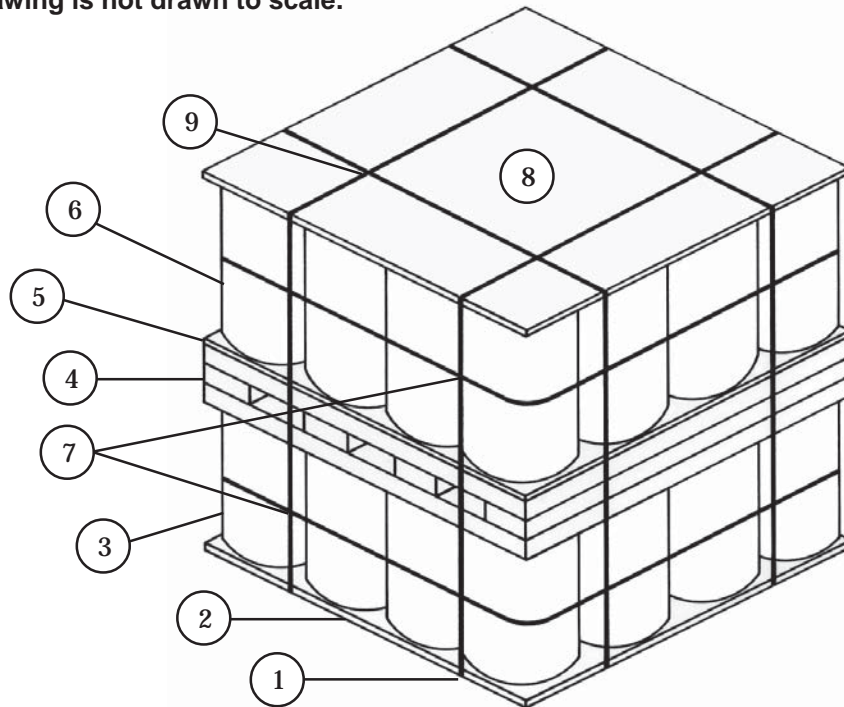
**Figure 10-1. Cases of Oil Rigged**



## EQUIPMENT REQUIRED

10-6. Use the equipment listed in Table 10-1 to rig the petroleum products. However, the equipment will vary from load to load.

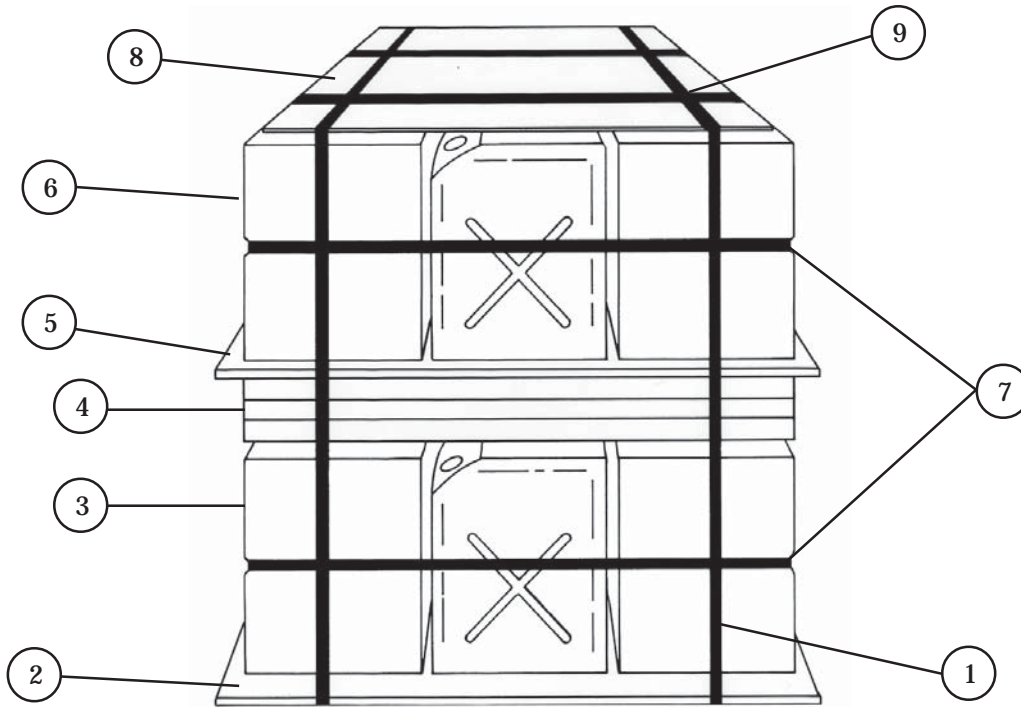
NOTE: This drawing is not drawn to scale.



- ① Repeat step 1 of Figure 10-1.
- ② Center a 3/4- by 48- by 48-inch piece of plywood on top of the container.
- ③ Place sixteen 5-gallon drums on top of the plywood.
- ④ Repeat steps 4 through 6 of Figure 10-1 to form three layers of honeycomb.
- ⑤ Place a 3/4- by 48- by 48-inch piece of plywood on top of the honeycomb.
- ⑥ Position sixteen 5-gallon drums on top of the plywood.
- ⑦ Wrap a length of steel strapping around each layer of drums. Bind the strapping in place.
- ⑧ Place a 3/4- by 45- by 45-inch piece of plywood on top of the load.
- ⑨ Bind the steel strapping over the top of the load. Use four seals to secure each piece of steel strapping. Cut off excess if necessary. Pad the 5-gallon drums as necessary.

Figure 10-2. Five-Gallon Drums Rigged

**NOTE: This drawing is not drawn to scale.**



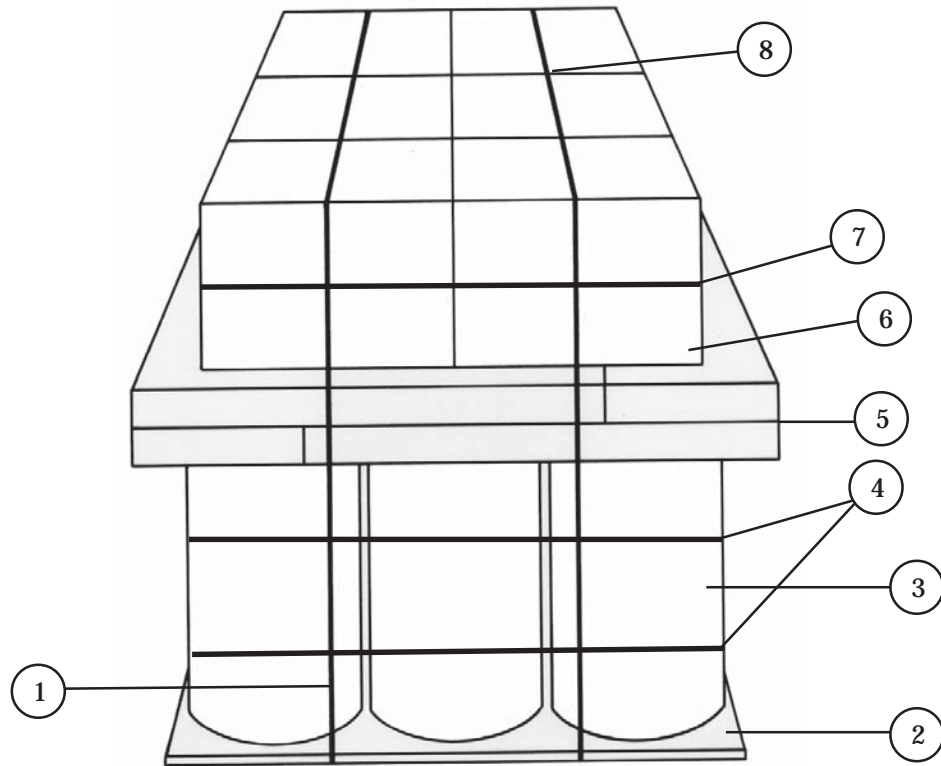
- ① Repeat step 1 of Figure 10-1.
- ② Center a 3/4- by 48- by 48-inch piece of plywood on top of the container.
- ③ Position 21 cans on top of the plywood (three rows wide and seven in each row). Wrap every other can with cellulose wadding or cardboard sheets.

**NOTE: Make sure the 5-gallon cans are filled not more than 1-inch below filler threads.**

- ④ Position three layers of honeycomb. Use a 36- by 48-inch and a 12- by 48-inch piece of honeycomb in each layer. Alternate the pieces of honeycomb in each layer.
- ⑤ Lay a 3/4- by 48- by 48-inch piece of plywood on top of the honeycomb layers.
- ⑥ Repeat step 3.
- ⑦ Wrap a length of steel strapping around each layer of cans. Bind the strapping in place.
- ⑧ Place a 3/4- by 44- by 44-inch piece of plywood on top of the load.
- ⑨ Bind the steel strapping over the top of the load. Use four seals to secure each piece of steel strapping. Cut off excess if necessary. Pad the 5-gallon cans as necessary.

**Figure 10-3. Five-Gallon Fuel Cans Rigged**

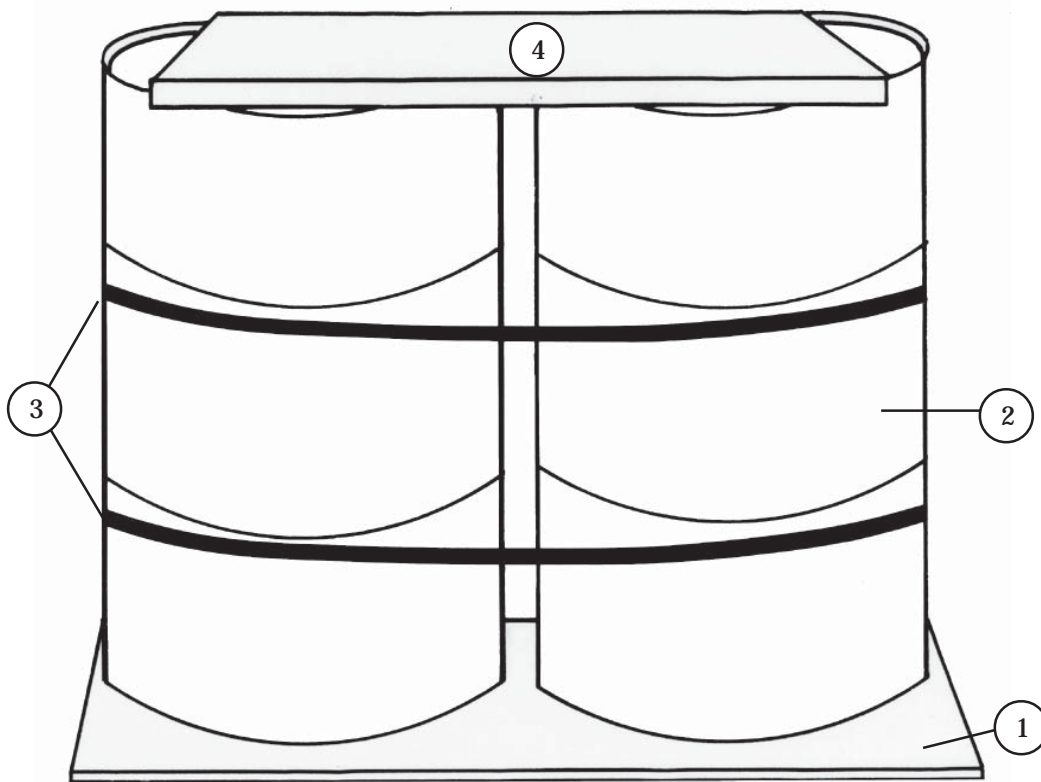
**NOTE: This drawing is not drawn to scale.**



- ① Repeat step 1 of Figure 10-1.
- ② Center a 3/4- by 48- by 48-inch piece of plywood on top of the container.
- ③ Place nine 30-gallon drums on top of the plywood. Pad the 30-gallon drums as necessary.
- ④ Evenly space two 18-foot lengths of steel strapping around the drums. Bind the strapping in place.
- ⑤ Position two layers of honeycomb. Use a 36- by 48-inch and a 12- by 48-inch piece of honeycomb in each layer. Alternate the pieces of honeycomb in each layer.
- ⑥ Place six cases of oil on top of honeycomb.
- ⑦ Wrap a length of steel strapping around the cases. Bind the strapping in place.
- ⑧ Bind the steel strapping over the top of the load. Use four seals to secure each piece of steel strapping. Cut off excess if necessary.

**Figure 10-4. Thirty-Gallon Grease Drums and Cases of Oil Rigged**

**NOTE:** This drawing is not drawn to scale.



- ① Center a 3/4- by 48- by 48-inch piece of plywood on top of the container.
- ② Place four 55-gallon drums on top of the plywood.
- ③ Wrap two 16-foot lengths of 1/2-inch tubular nylon webbing around the drums. Make sure each length is just above the grooves on the drums. Secure each length of webbing together using a trucker's hitch knot.
- ④ Center a 3/4- by 36- by 36-inch piece of plywood on top of the load.

**Figure 10-5. Fifty-Five Gallon Drums Rigged**

**Table 10-1. Equipment Required for Rigging Petroleum Products in an A-22 Cargo Bag**

National Stock Number	Item	Quantity
8040-00-273-8713	Adhesive, paste, 1-gallon	As required
1670-00-587-3421	Bag, cargo, A-22	1
4020-00-240-2146	Cord, nylon, type III	As required
8135-00-664-6958	Cushioning material, packaging, cellulose wadding	As required
1670-00-753-3928	Pad, energy-dissipating material, honeycomb	As required
1670-00-065-3755	Parachute	1
1670-00-872-6109	G-12E High-velocity, 26-foot	1
5530-00-129-7777	Plywood: 1/2- by 48- by 96-inch	As required
5530-00-128-4981	3/4- by 48- by 96-inch	As required
1670-00-883-1654	Skid, cargo bag, platform, plywood	1
8135-00-283-0667	Strapping, steel, 5/8-inch	As required
7510-00-266-6710	Tape, masking, 2-inch	As required
8310-01-102-4478	Thread, cotton, ticket number 8/7	As required
8305-00-268-2411	Webbing: Cotton, 1/4-inch, type I	As required
8305-00-082-5752	Nylon, tubular, 1/2-inch	As required

**This page intentionally left blank.**

## Chapter 11

# Rigging Specific Double A-22 Loads

## SECTION I - RIGGING SNOWMOBILE

### DESCRIPTION OF LOAD

11-1. The snowmobile is rigged in a double A-22 cargo bag for low-velocity airdrop. The load requires one G-12E cargo parachute equipped with a 68-inch pilot parachute. The snowmobile is 118 inches in length, reducible to 104 inches. Its width is 36 inches. The height of the snowmobile is 49 inches, reducible to 47 inches. Twenty cases of rations are rigged with the snowmobile.

### PREPARING SKID BOARD

11-2. Prepare the standard double A-22 skid board as shown in Figures 9-12 and 9-13. Form two honeycomb layers using one 36- by 92-inch and one 8- by 92-inch piece of honeycomb to form each layer. Alternate the pieces of honeycomb in each layer.

### POSITIONING CONTAINER

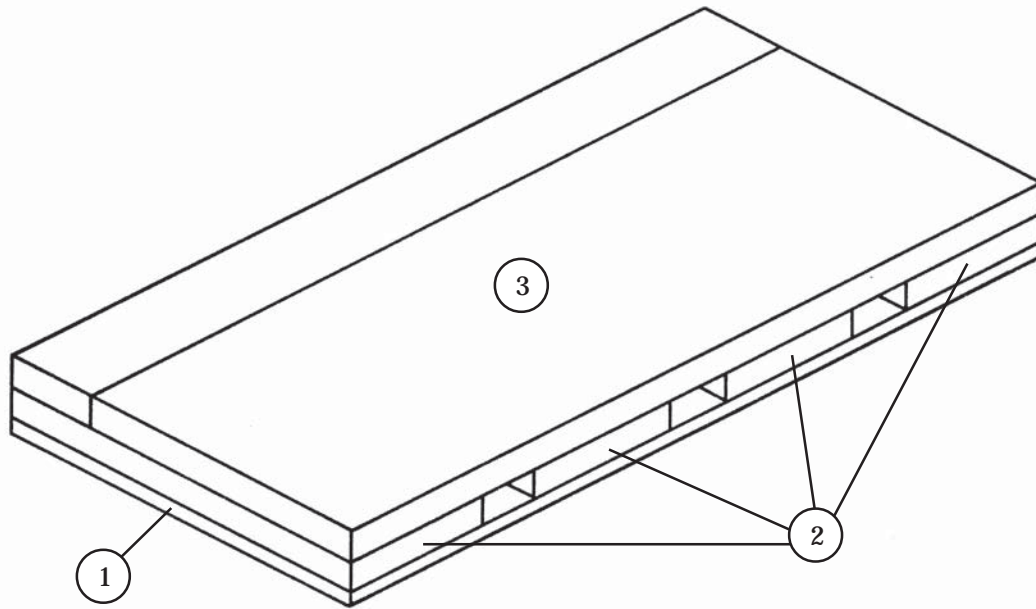
11-3. Position two A-22 cargo bags as shown in Figures 9-14 and 9-15.

### POSITIONING HONEYCOMB

11-4. Position the honeycomb as shown in Figure 11-1.

**NOTE:** Various models of snowmobiles differ slightly and may require a modification to procedures.

**NOTE:** This drawing is not drawn to scale.

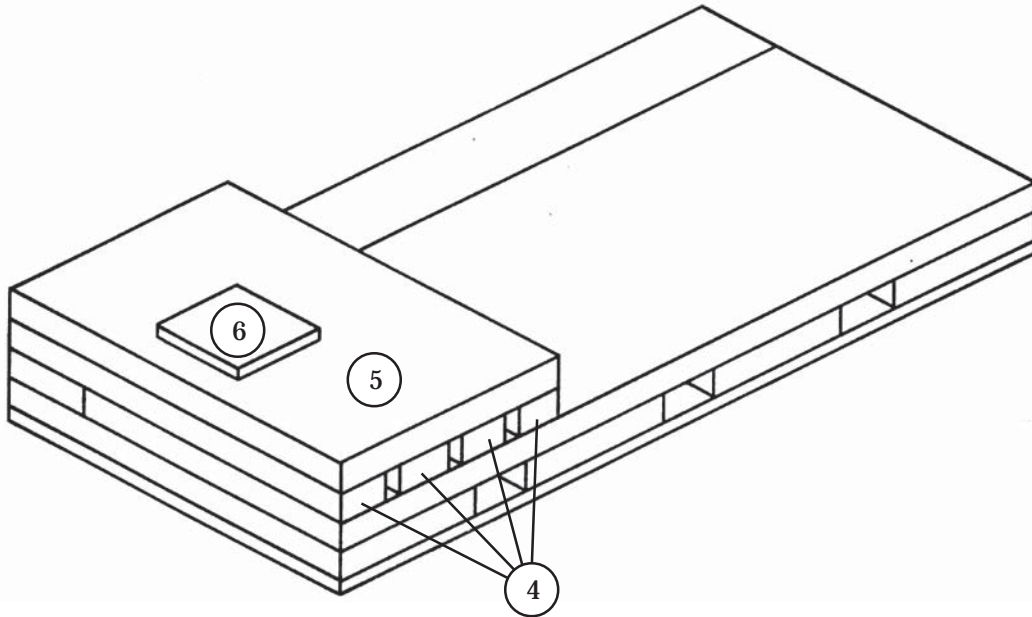


- ① Center a 3/4- by 48- by 96-inch piece of plywood on top of the cover.
- ② Evenly space four 18- by 48-inch pieces of honeycomb on top of the plywood.
- ③ Place a 36- by 96-inch and a 12- by 96-inch piece of honeycomb on top of the first layer of honeycomb.

**Figure 11-1. Honeycomb Positioned**



**NOTE: This drawing is not drawn to scale.**



- ④ Cut four 6- by 48-inch pieces of honeycomb. Place one piece flush with the rear edge of the second layer of honeycomb. Place the remaining three pieces 2 inches apart from each other.
- ⑤ Place a 30- by 48-inch piece of honeycomb flush with the rear edge of the third layer of honeycomb.
- ⑥ Center a 3/4- by 12- by 12-inch piece of plywood 8 inches from the rear on top of the fourth layer of honeycomb.

**Figure 11-1. Honeycomb Positioned (Continued)**

## PREPARING SNOWMOBILE

11-5. Prepare the snowmobile as shown in Figure 11-2.

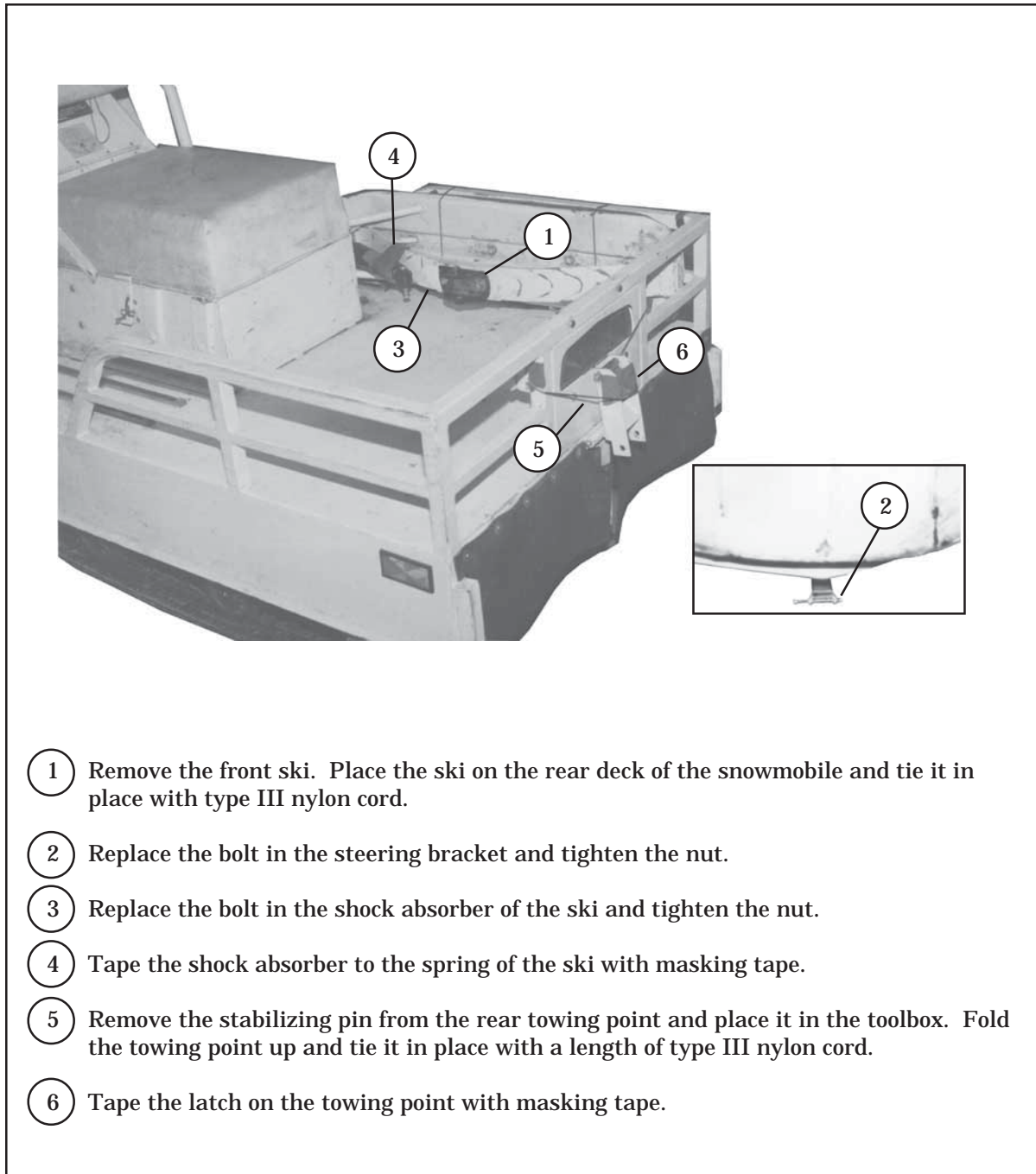
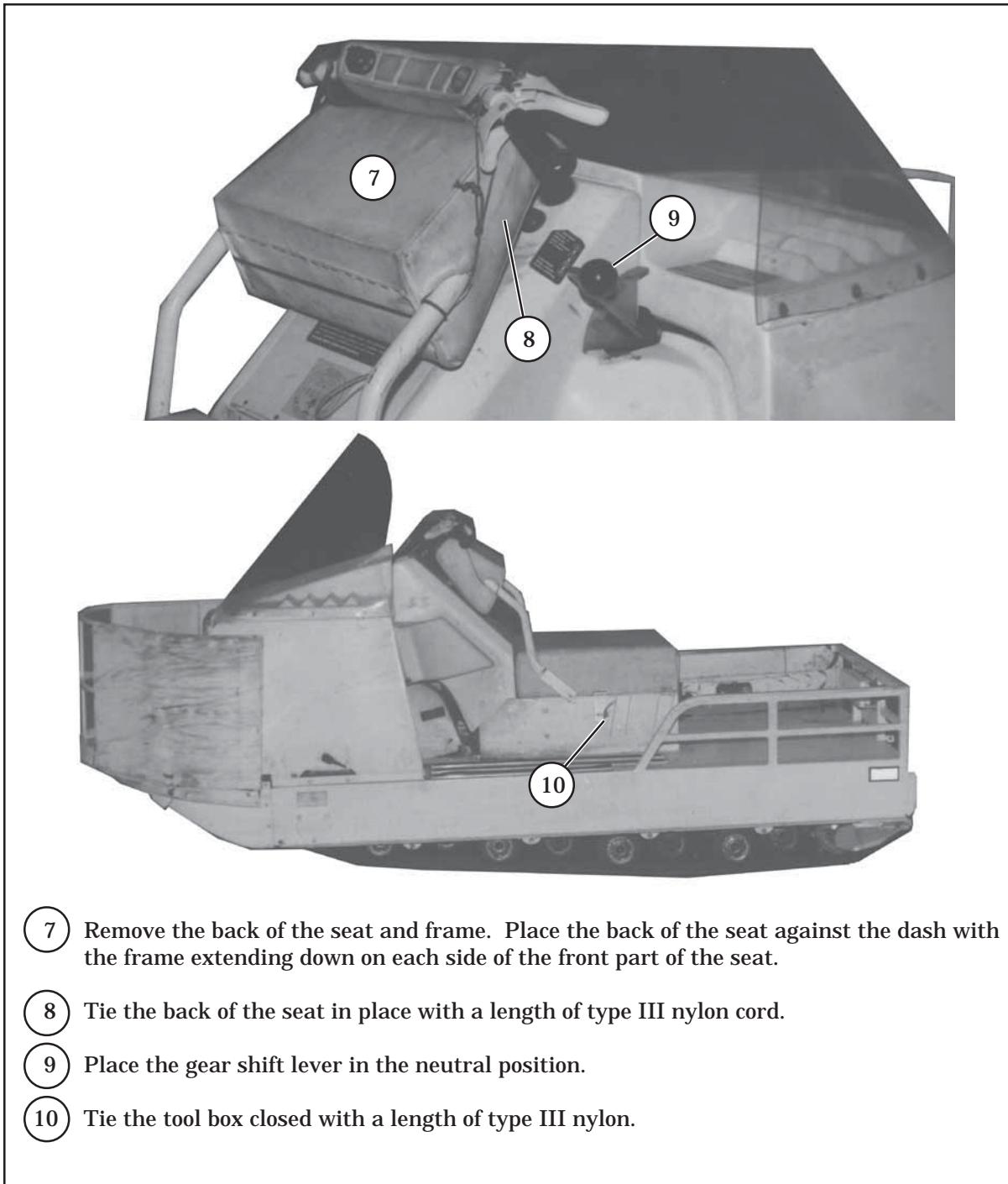


Figure 11-2. Snowmobile Prepared



- 7 Remove the back of the seat and frame. Place the back of the seat against the dash with the frame extending down on each side of the front part of the seat.
- 8 Tie the back of the seat in place with a length of type III nylon cord.
- 9 Place the gear shift lever in the neutral position.
- 10 Tie the tool box closed with a length of type III nylon.

Figure 11-2. Snowmobile Prepared (Continued)

## POSITIONING LOAD

11-6. Position the snowmobile as shown in Figure 11-3. Position the rations as shown in Figure 11-4.

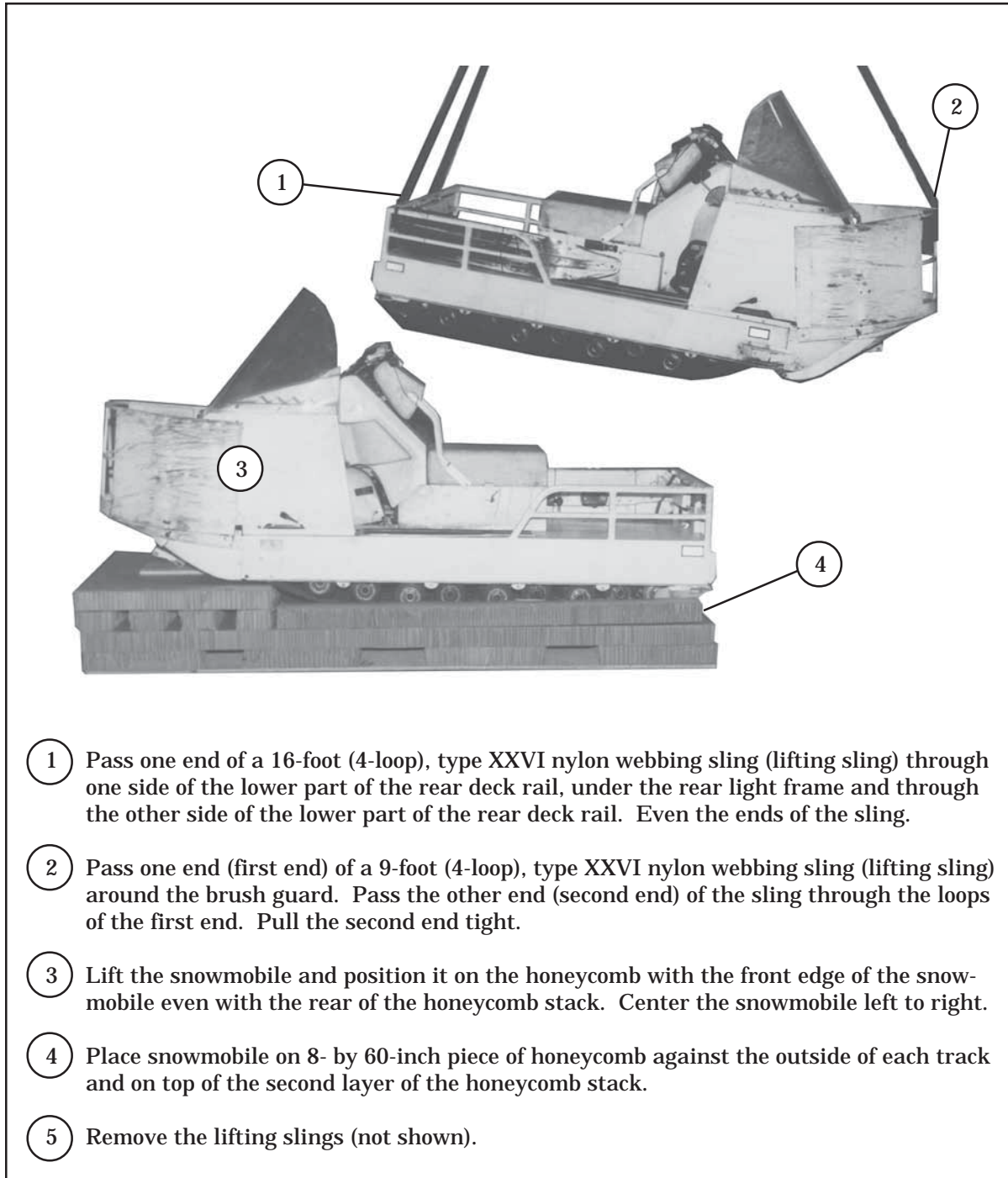
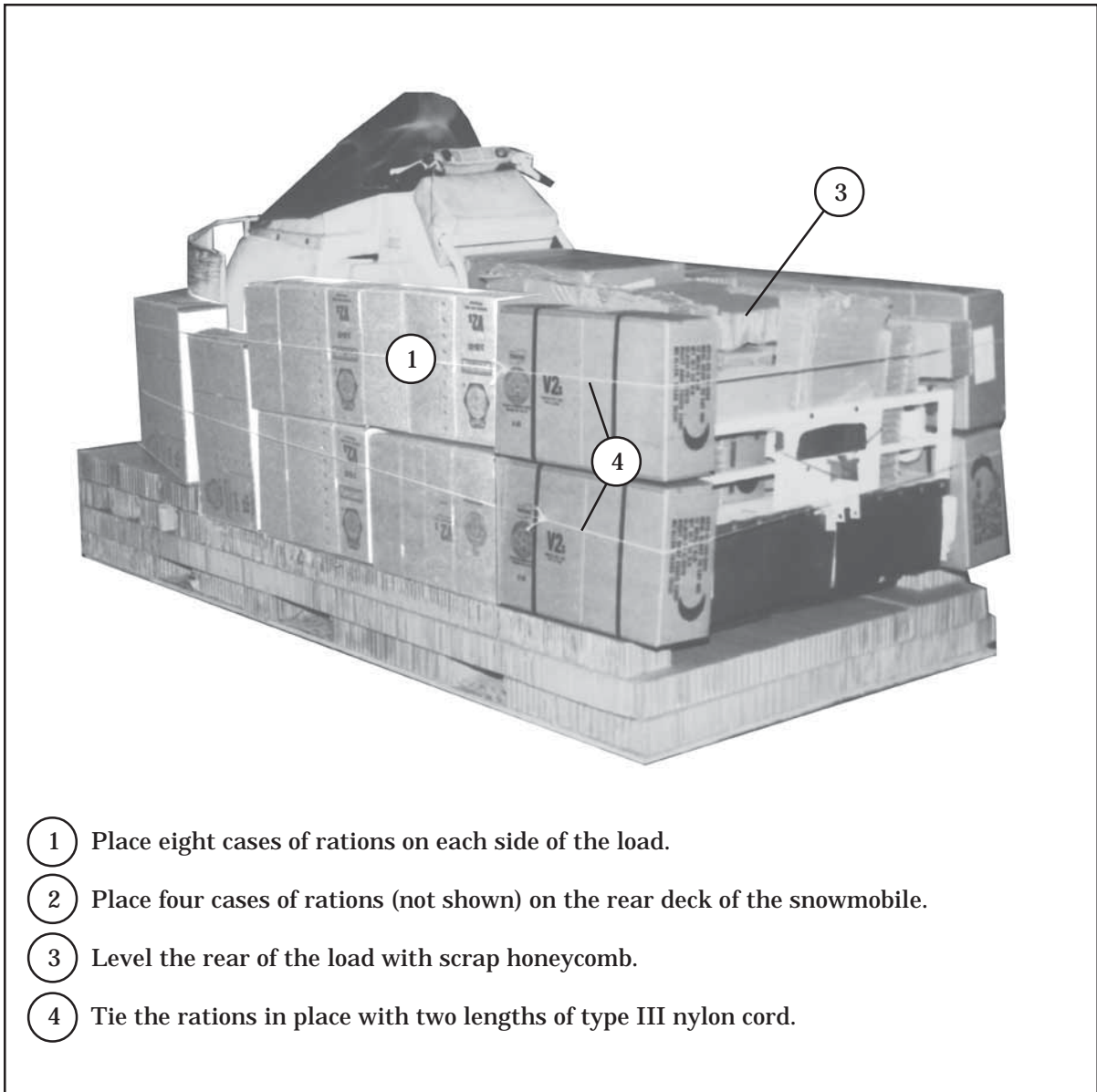


Figure 11-3. Snowmobile Positioned



- ① Place eight cases of rations on each side of the load.
- ② Place four cases of rations (not shown) on the rear deck of the snowmobile.
- ③ Level the rear of the load with scrap honeycomb.
- ④ Tie the rations in place with two lengths of type III nylon cord.

**Figure 11-4. Rations Positioned**

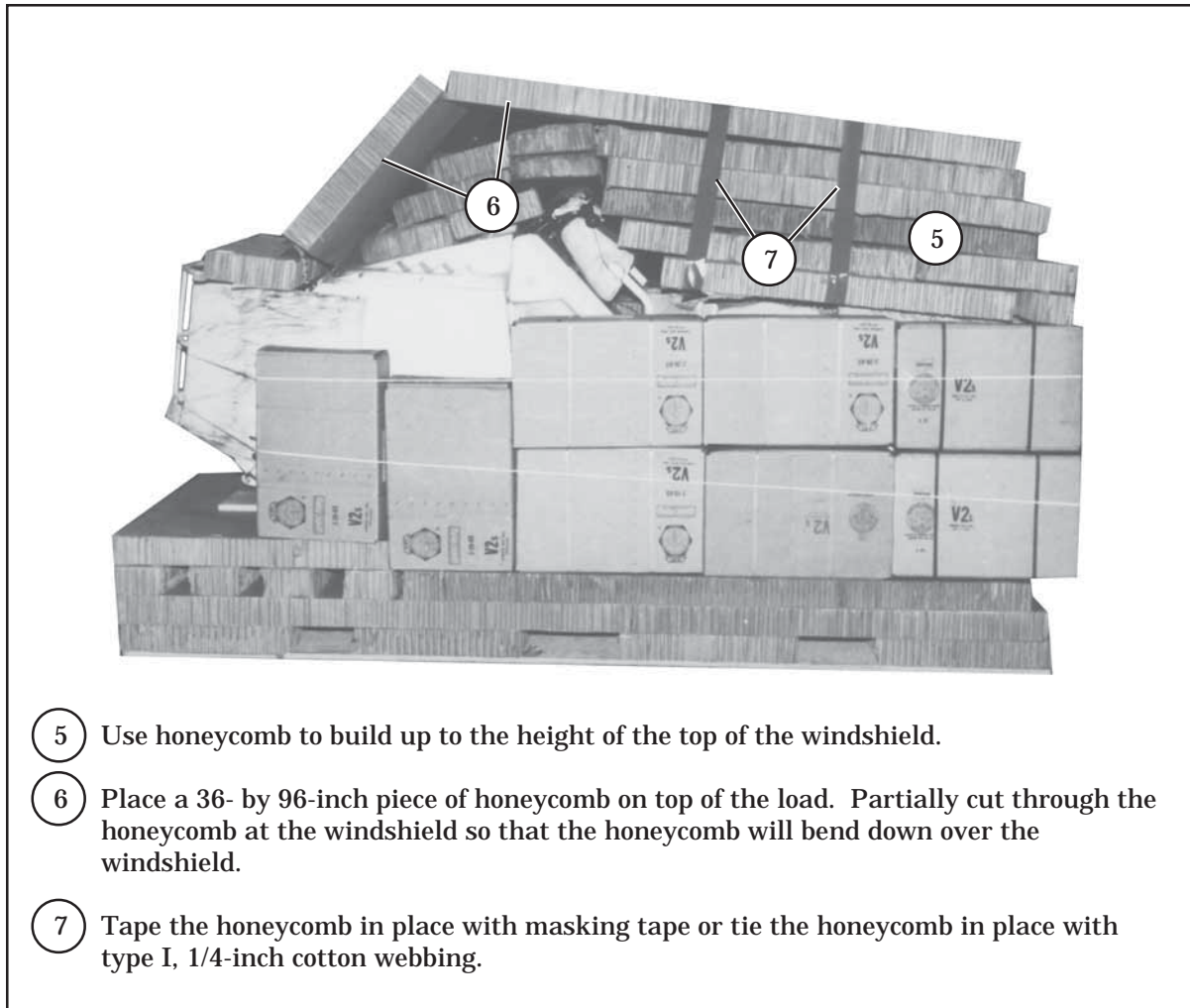


Figure 11-4. Rations Positioned (Continued)

## COMPLETING RIGGED LOAD

11-7. Complete the rigging of the load according to Paragraphs 9-16 through 9-21.

## MARKING RIGGED LOAD

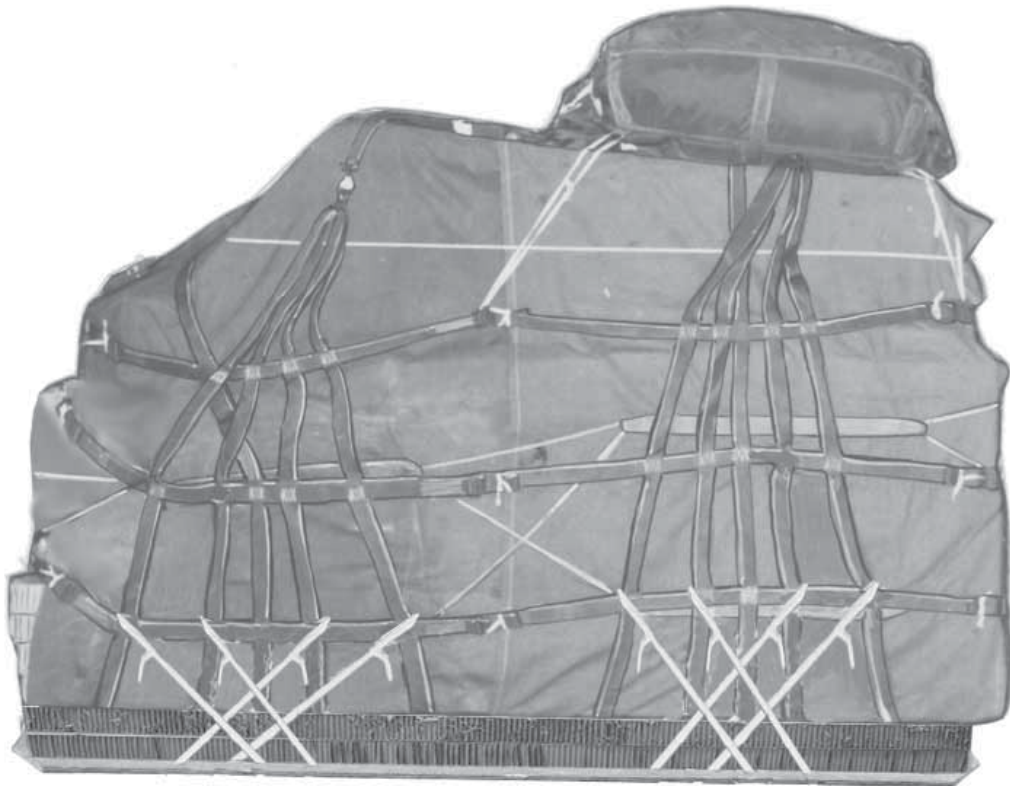
11-8. Mark the rigged load according to Paragraph 1-5 using the data given in Figure 11-5. If the load varies from the one shown in Figure 11-5, recompute the data.

## EQUIPMENT REQUIRED

11-9. Use the equipment listed in Table 11-1 to rig the load shown in Figure 11-5.

**CAUTION**

Make the final rigger inspection required by FM 4-20.102/NAVSEA SS400-AB-MMO-010/TO 13C7-1-5 and AR 59-4/OPNAVINST 4630.24C/AFJ 13-210(I)/MCO 13480.1B before the load leaves the rigging site.



**RIGGING LOAD DATA SNOWMOBILE**

Weight: Load shown.....	1,654 pounds
Maximum load allowed .....	2,200 pounds
Height (with one G-12E cargo parachute) .....	67 inches
Width .....	48 inches
Overall Length.....	104 inches

**Figure 11-5. Snowmobile Rigged in a Double A-22 Cargo Bag for Low-Velocity Airdrop**

**Table 11-1. Equipment Required For Rigging The Snowmobile In A Double A-22 Cargo Bag For Low-Velocity Airdrop**

National Stock Number	Item	Quantity
8040-00-273-8713	Adhesive, paste, 1-gallon	As required
1670-00-587-3421	Bag, cargo, A-22	2
4030-00-678-8562	Clevis, suspension, 3/4-inch (medium)	2
4020-00-240-2146	Cord, nylon, type III	As required
8135-00-664-6958	Cushioning material, packaging, cellulose wadding	As required
1670-00-753-3928	Pad, energy-dissipating material, honeycomb Parachute	7 sheets
1670-01-065-3755	Cargo, G-12E	1
1670-00-216-7297	Pilot, 68-inch diameter	1
5530-00-128-4981	Plywood: 3/4- by 48- by 96-inch	1 sheet
5530-00-914-5118	1- by 48- by 96-inch	1 sheet
1670-01-062-6301	Sling, type XXVI nylon webbing 3-foot (2-loop)	3
1670-00-432-2501	9-foot (4-loop)	1
1670-00-432-2505	16-foot (4-loop)	1
7510-00-266-6710	Tape, masking, 2-inch	As required
8310-01-102-4478	Thread, cotton, ticket number 8/7	As required
8305-00-268-2411	Webbing: Cotton, 1/4-inch, type I	As required
8305-00-082-5752	Nylon: Tubular, 1/2-inch	As required
8305-00-263-3591	Type VIII	As required
8305-00-260-6890	Type X	As required



## **SECTION II - RIGGING AHKIO SLEDS**

### **DESCRIPTION OF LOAD**

11-10. Four ahkio sleds are rigged in a double A-22 cargo bag. The sleds are filled with at least 200 pounds of equipment in each sled. The load uses a G-12E cargo parachute. Each sled is 24 inches wide, 88 inches long and 8 inches high. It weighs 38 pounds and can carry up to 500 pounds of equipment.

### **PREPARING SKID BOARD AND POSITIONING HONEYCOMB AND CONTAINER**

11-11. Prepare a typical double A-22 skid board as shown in Figure 9-12. Position two layers of honeycomb on the skid board as shown in Figure 9-13. Position the A-22 sling assembly according to Paragraph 9-23. Position the A-22 covers according to Paragraph 9-24.

### **POSITIONING LOAD**

11-12. Position the load according to Figure 11-6. Make sure the sleds have rations, equipment, or other items positioned inside so that the load will weigh at least 900 pounds without the weight of the parachute.

### **COMPLETING RIGGED LOAD**

11-13. Complete the rigging of the load according to Paragraphs 9-25 through 9-30.

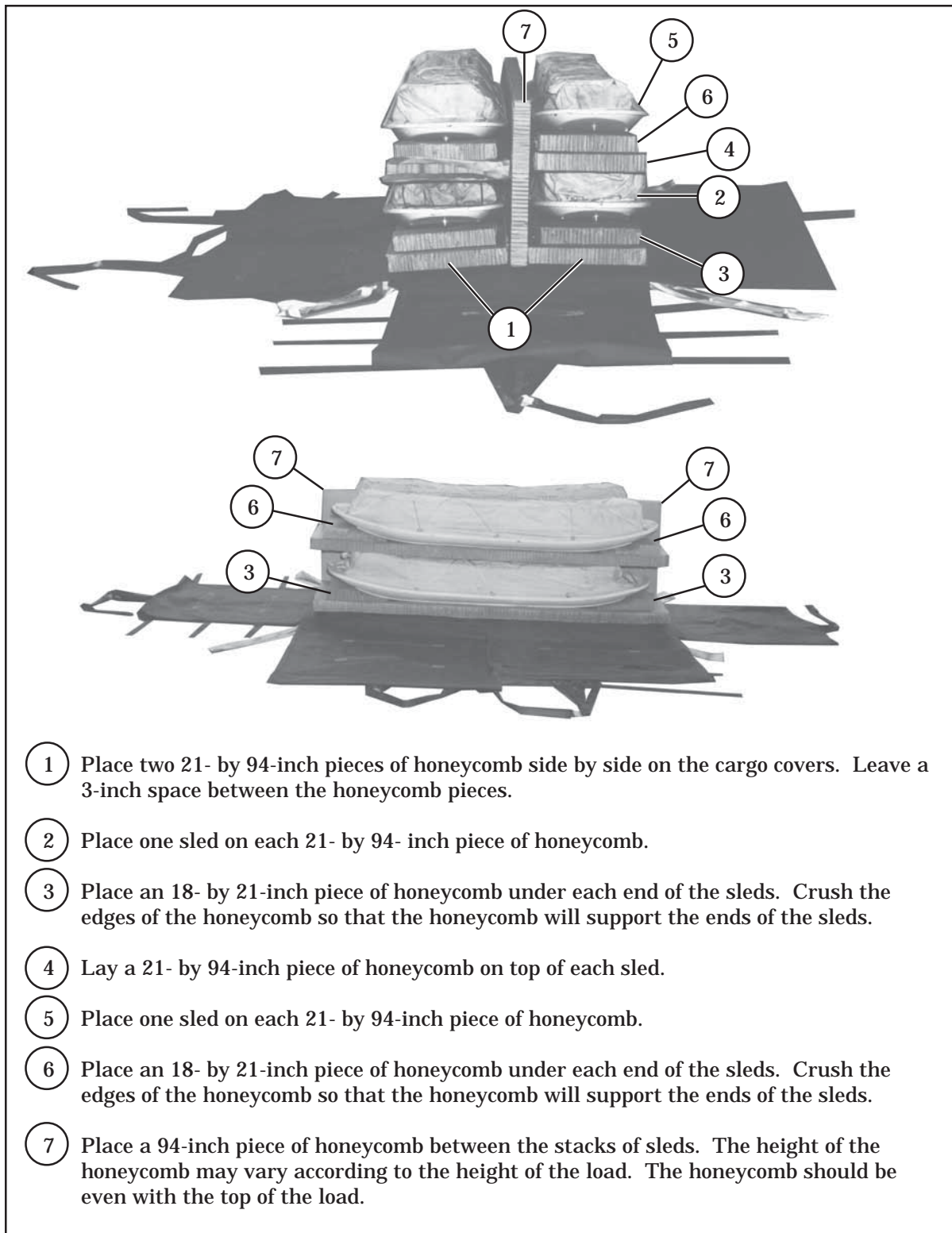


Figure 11-6. Load Positioned

**MARKING RIGGED LOAD**

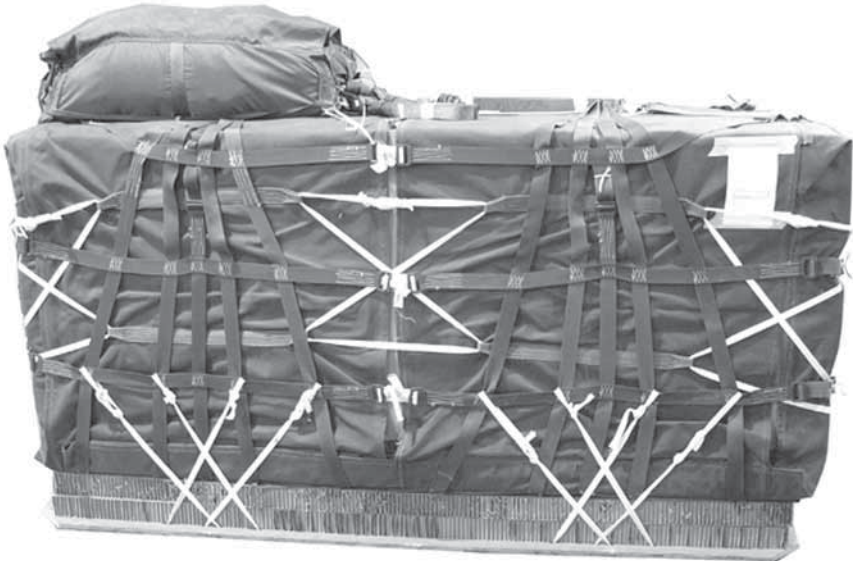
11-14. Mark the rigged load according to Paragraph 1-5 using the data given in Figure 11-7. Each load must be computed due to varying accompanying loads. Make sure the load weighs at least 900 pounds.

**EQUIPMENT REQUIRED**

11-15. Use the equipment listed in Table 11-2 to rig the load shown in Figure 11-7.

**CAUTION**

Make the final rigger inspection required by FM 4-20.102/NAVSEA SS400-AB-MMO-010/TO 13C7-1-5 and AR 59-4/OPNAVINST 4630.24C/AFJ 13-210(I)/MCO 13480.1B before the load leaves the rigging site.



**RIGGING LOAD DATA AHKIO SLEDS**

Weight: minimum load allowed .....	900 pounds
Maximum load allowed .....	2,200 pounds
Height (with one G-12E cargo parachute) .....	up to 83 inches
Width .....	48 inches
Length .....	96 inches

**Figure 11-7. Ahkio Sleds Rigged in a Double A-22 Cargo Bag for Low-Velocity Airdrop**

**Table 11-2. Equipment Required For Rigging Ahkio Sleds In A Double A-22 Cargo Bag For Low-Velocity Airdrop**

National Stock Number	Item	Quantity
8040-00-273-8713	Adhesive, paste, 1-gallon	As required
1670-00-587-3421	Bag, cargo, A-22	2
4030-00-678-8562	Clevis, suspension, 3/4-inch (medium)	2
4020-00-240-2146	Cord, nylon, type III	As required
8135-00-664-6958	Cushioning material, packaging, cellulose wadding	As required
1670-00-753-3928	Pad, energy-dissipating material, honeycomb	7 sheets
	Parachute	
1670-01-065-3755	Cargo, G-12E	1
1670-00-216-7297	Pilot, 68-inch diameter	1
	Plywood, (skid board)	
5530-00-128-4981	3/4- by 48- by 96-inch	1 sheet
	or	
5530-00-914-5118	1- by 48- by 96-inch	1 Sheet
1670-01-062-6301	Sling, type XXVI nylon webbing 3-foot (2-loop)	3
7510-00-266-6710	Tape, masking, 2-inch	As required
8310-01-102-4478	Thread, cotton, ticket number 8/7	As required
	Webbing:	
8305-00-268-2411	Cotton, 1/4-inch, type I	As required
	Nylon:	
8305-00-082-5752	Tubular, 1/2-inch	As required
8305-00-263-3591	Type VIII	As required
8305-00-260-6890	Type X	As required

**PART FIVE****RIGGING LOW-COST AERIAL DELIVERY SYSTEM****Chapter 12****General Information and Procedures****LCADS COMPONENTS**

12-1. LCADS is a modified, lightweight A-22 system with no scuff pad, cover, suspension webs, or friction adapters on the lateral bands. LCADS is used for high-volume delivery of non-fragile items where airdrop equipment is not recoverable. The LCADS shown in Figure 12-1, employs a lower cost version of the A-22 sling assembly. The low cost sling assembly uses a more readily available and more economical material and eliminates much of the hardware thus reducing the costs.

**LCADS SKID BOARD**

12-2. Like the standard A-22 container, the sling assembly is secured to a 3/4 or 1- by 48- by 48-inch piece plywood (Grade AC) skid board with 1/2-inch tubular nylon webbing. Honeycomb is positioned between the container and the skid board for impact cushioning.



Figure 12-1. Fully Rigged LCADS for High-Velocity Airdrop

## LCADS CONTAINER LIMITATIONS

12-3. The LCADS container has a weight restriction of 501 to 2,200 pounds.

## INSPECTING LOAD

12-4. The LCADS must be inspected by a qualified rigger. While being rigged this load should be supervised or rigged by a parachute rigger. DD Form 1748-1 must be completed before airdrop.

## PARACHUTE USED

12-5. There are three types of parachutes used for LCADS loads, depending on whether the load is being dropped for low-velocity or high-velocity airdrop.

a. **LOW-VELOCITY DROPS.** The G-12E cargo parachute is the primary parachute for low-velocity airdrops. It is rated for 501 to 2,200 pounds of suspended weight. A 68-inch pilot parachute is installed on the G-12E cargo parachute to deploy it. Other parachutes may be used to deploy the G-12E cargo parachute; however, the specific manual must give the procedures.

b. **HIGH-VELOCITY PARACHUTE.**

(1) **Primary Parachute.** The 26-foot low-cost parachute performs identical to the standard 26-foot high-velocity parachute except the low cost parachute is designated for one-time use. The low cost parachute is pre-packed and ready to attach to the load.

(2) **Alternate Parachute.** The 26-foot high-velocity cargo parachute is rated for 501 to 2,200 pounds of suspended weight. TM 10-1670-279-23&P/TO 13C5-27-2/NAVAIR 13-1-28 covers the inspection and packing of the parachute.

## Chapter 13

# Rigging Typical Low-Cost Aerial Delivery System Loads

## SECTION I - RIGGING LCADS FOR LOW-VELOCITY AIRDROP

### SYSTEM DESCRIPTION

13-1. The LCADS is rigged as a typical A-22 low-velocity load. Typical loads include rations, repair parts, water, and/or other small items. Items may be dropped in their original configuration or repackaged for greater protection. The LCADS container loads must weigh at least 501 pounds but not exceed 2,200 pounds excluding the parachute. The load is rigged with a G-12E cargo parachute.

### PREPARING ITEMS AND SKID BOARD

13-2. Prepare the skid board using Figure 9-1. Prepare the items to be dropped according to load's sensitivity. Items must be well padded to prevent damage during airdrop.

### PREPARING AND PLACING HONEYCOMB

13-3. Prepare and place the honeycomb as shown in Figure 9-2.

## POSITIONING SLING ASSEMBLY

13-4. Center the sling assembly over the honeycomb and skid board as shown in Figure 13-1. The dimensions of the webbing is 222 by 222 inches.

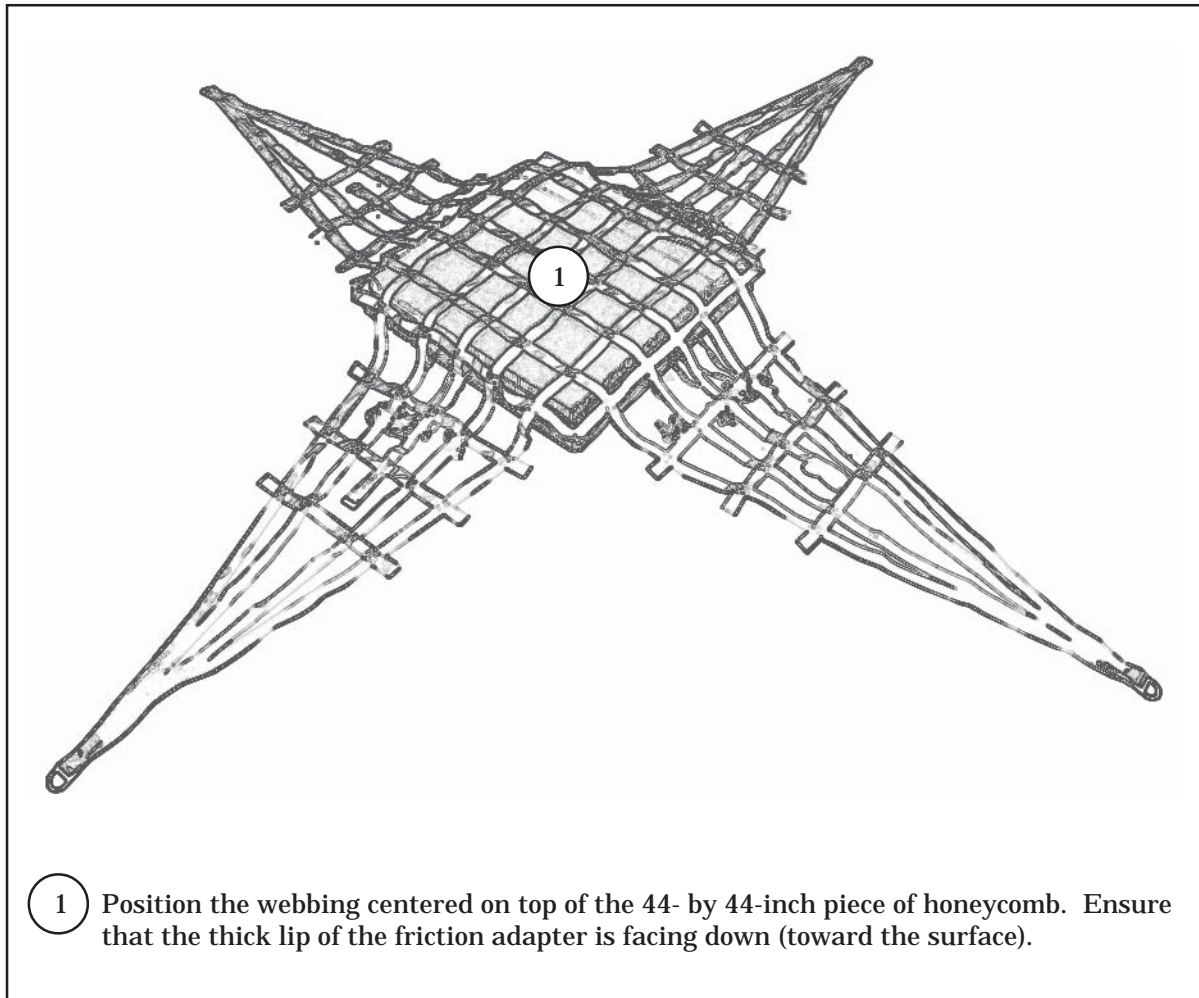
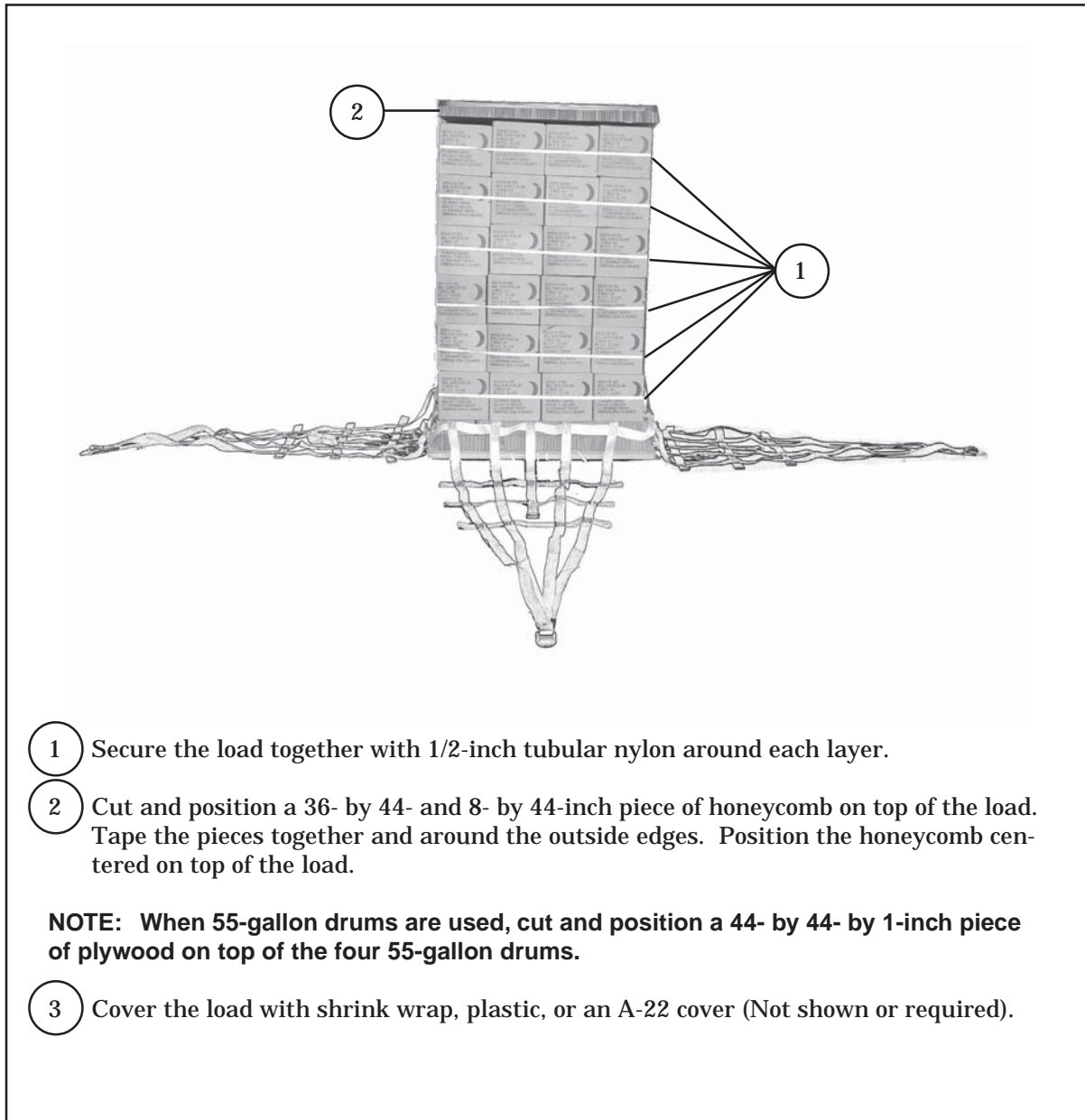


Figure 13-1. Sling Assembly Positioned



## POSITIONING LOAD AND SECURING SLING ASSEMBLY

13-5. Center and secure the load on the sling assembly and honeycomb. If a cover is available, cover the load with a plastic bag, shrink wrap or an A-22 cargo cover. A cover is not required. Secure and tie the sling assembly as shown in Figure 13-2.



- 1 Secure the load together with 1/2-inch tubular nylon around each layer.
  - 2 Cut and position a 36- by 44- and 8- by 44-inch piece of honeycomb on top of the load. Tape the pieces together and around the outside edges. Position the honeycomb centered on top of the load.
- NOTE:** When 55-gallon drums are used, cut and position a 44- by 44- by 1-inch piece of plywood on top of the four 55-gallon drums.
- 3 Cover the load with shrink wrap, plastic, or an A-22 cover (Not shown or required).

Figure 13-2. Load Positioned and Sling Secured



## SECURING SLING ASSEMBLY TO SKID BOARD

13-6. Tie the sling assembly to the skid board as shown in Figure 13-3.

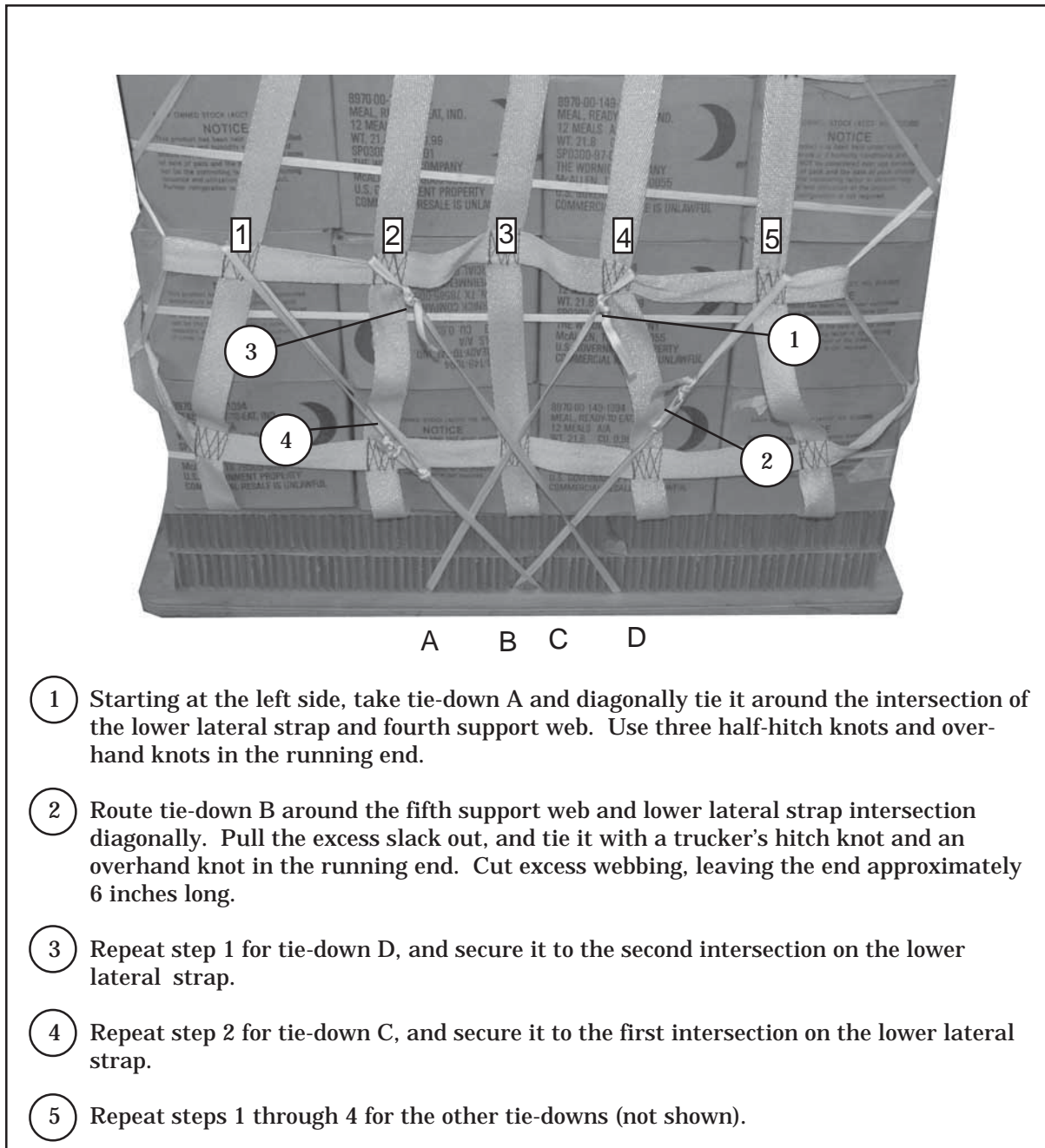
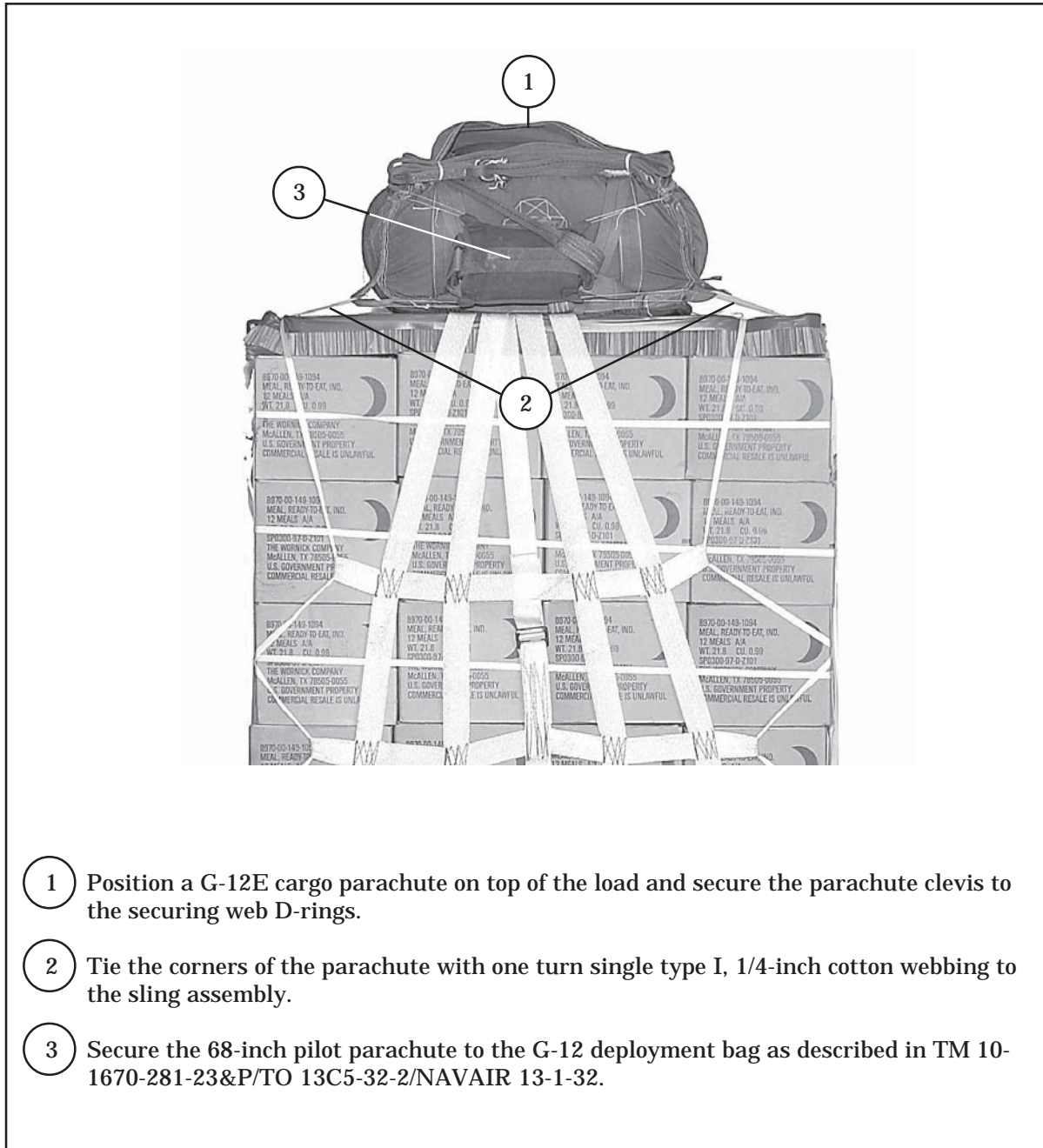


Figure 13-3. Skid Board Secured

## INSTALLING PARACHUTE

13-7. Install the G-12E cargo parachute as shown in Figure 13-4.



- 1 Position a G-12E cargo parachute on top of the load and secure the parachute clevis to the securing web D-rings.
- 2 Tie the corners of the parachute with one turn single type I, 1/4-inch cotton webbing to the sling assembly.
- 3 Secure the 68-inch pilot parachute to the G-12 deployment bag as described in TM 10-1670-281-23&P/TO 13C5-32-2/NAVAIR 13-1-32.

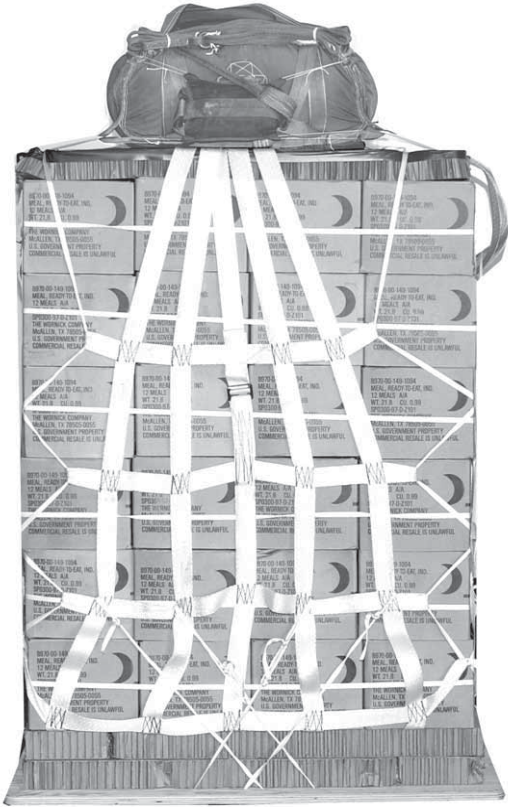
Figure 13-4. G-12E Cargo Parachute Installed

## MARKING RIGGED LOAD

13-8. Mark the rigged load according to Paragraph 1-5 and as shown in Figure 13-5. Compute the rigged load data.

## EQUIPMENT REQUIRED

13-9. Use the equipment listed in Table 13-1 to rig the load shown in Figure 13-5.



**RIGGED LOAD**

Weight:	Minimum load allowed .....	501 pounds
	Maximum load allowed (without parachute) .....	2,200 pounds
Height:	.....	80 inches
Width:	.....	48 inches
Length:	.....	48 inches

Figure 13-5. LCADS Rigged for Low-Velocity Airdrop

**Table 13-1. Equipment Required for Rigging LCADS for Low-Velocity Airdrop**

National Stock Number	Item	Quantity
8040-00-273-8713	Adhesive paste, 1-gallon	As required
No NSN	Bag, cover, 4 mil polyethylene (54- by 52- by 60-inches)	As required
No NSN	Shrink wrap	As required
No NSN	Sling assembly, LCADS	1
4030-00-678-8562	Clevis, suspension, 3/4-inch (medium)	1
4020-00-240-2146	Cord, nylon type III	As required
1670-00-753-3928	Pad, energy dissipating material, honeycomb 36- by 96- by 3-inches	3 sheets
1670-00-893-2371	Parachute: Cargo, G-12E	1
1670-00-216-7297	Pilot, 68-inch diameter	1
5530-00-128-4981	Plywood, 3/4- by 48- by 96-inch or	1 sheet
5530-00-914-5118	Plywood, 1- by 48- by 96-inch or	1 sheet
1670-01-342-5913	Skid Board, 1- by 48- by 48-inch or	1
1670-00-883-1654	Skid Board, 3/4- by 48- by 48-inch	1
7510-00-266-6710	Tape, masking, 2-inch	As required
8310-01-102-4478	Thread, cotton, ticket number 8/7	As required
8305-00-268-2411	Webbing: Cotton, 1/4-inch, type I	As required
8305-00-082-5752	Nylon, tubular, 1/2-inch	As required

## SECTION II - RIGGING LCADS FOR HIGH-VELOCITY AIRDROP

### SYSTEM DESCRIPTION

13-10. The LCADS is rigged as a typical A-22 high-velocity load. Typical loads include rations, water, and other small items. LCADS container loads must weigh at least 501 pounds but not exceed 2,200 pounds, excluding the weight of the parachute. The load is rigged with a 26-foot low-cost parachute or a standard 26-foot high-velocity parachute.

### PREPARING ITEMS AND SKID BOARD

13-11. Refer to Figure 9-1 for preparation of the skid board. Prepare the drop items according to the load's sensitivity. Items must be well padded to prevent damage during airdrop.

### POSITIONING HONEYCOMB

13-12. Position honeycomb as shown in Figure 9-10.

### POSITIONING SLING ASSEMBLY

13-13. Center the sling assembly over the honeycomb and skid board as shown in Figure 13-6.

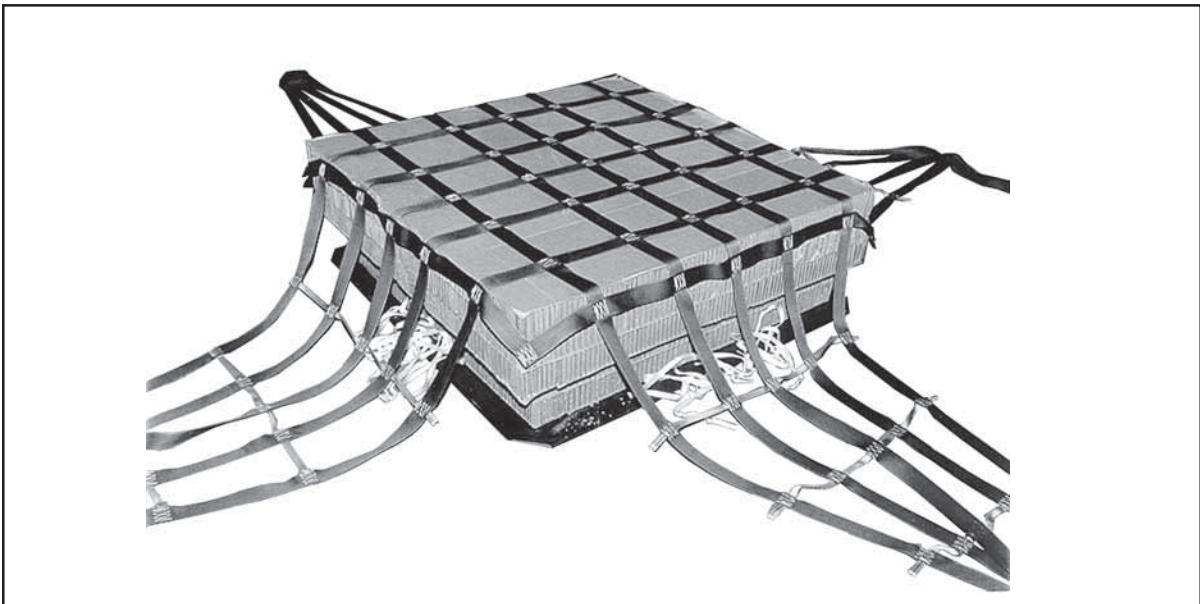


Figure 13-6. Sling Assembly Positioned

## POSITIONING LOAD AND SECURING SLING ASSEMBLY

13-14. Position load and secure sling assembly according to Figure 13-2.

## SECURING SLING ASSEMBLY TO SKID BOARD

13-15. Tie the sling assembly to the skid board as shown in Figure 13-7.

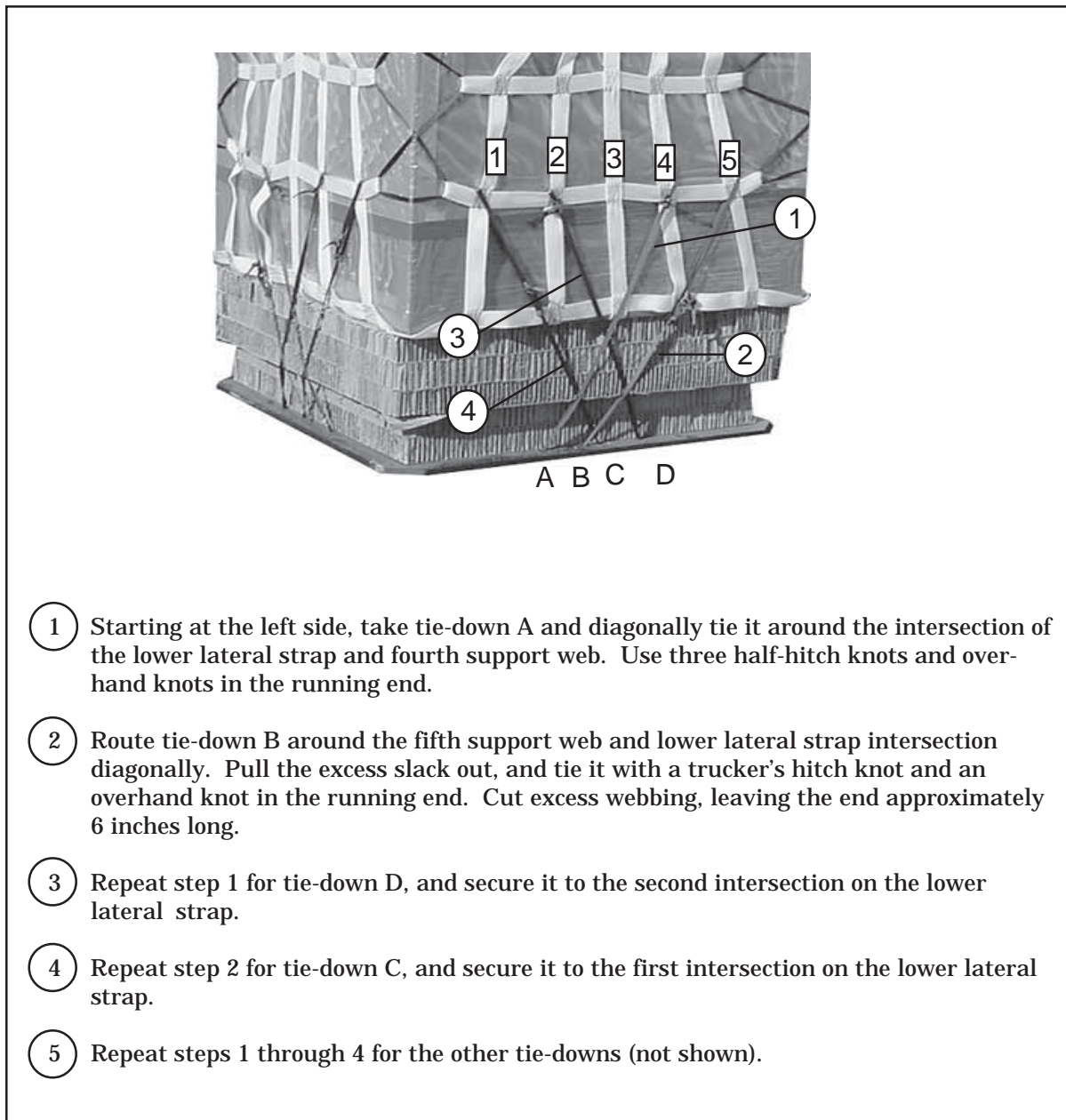


Figure 13-7. Skid Board Secured to Sling Assembly



## INSTALLING PARACHUTE

13-16. Install the LCADS high-velocity parachute as shown in Figure 13-8. Install the standard 26-foot high-velocity parachute according to Figure 8-5.

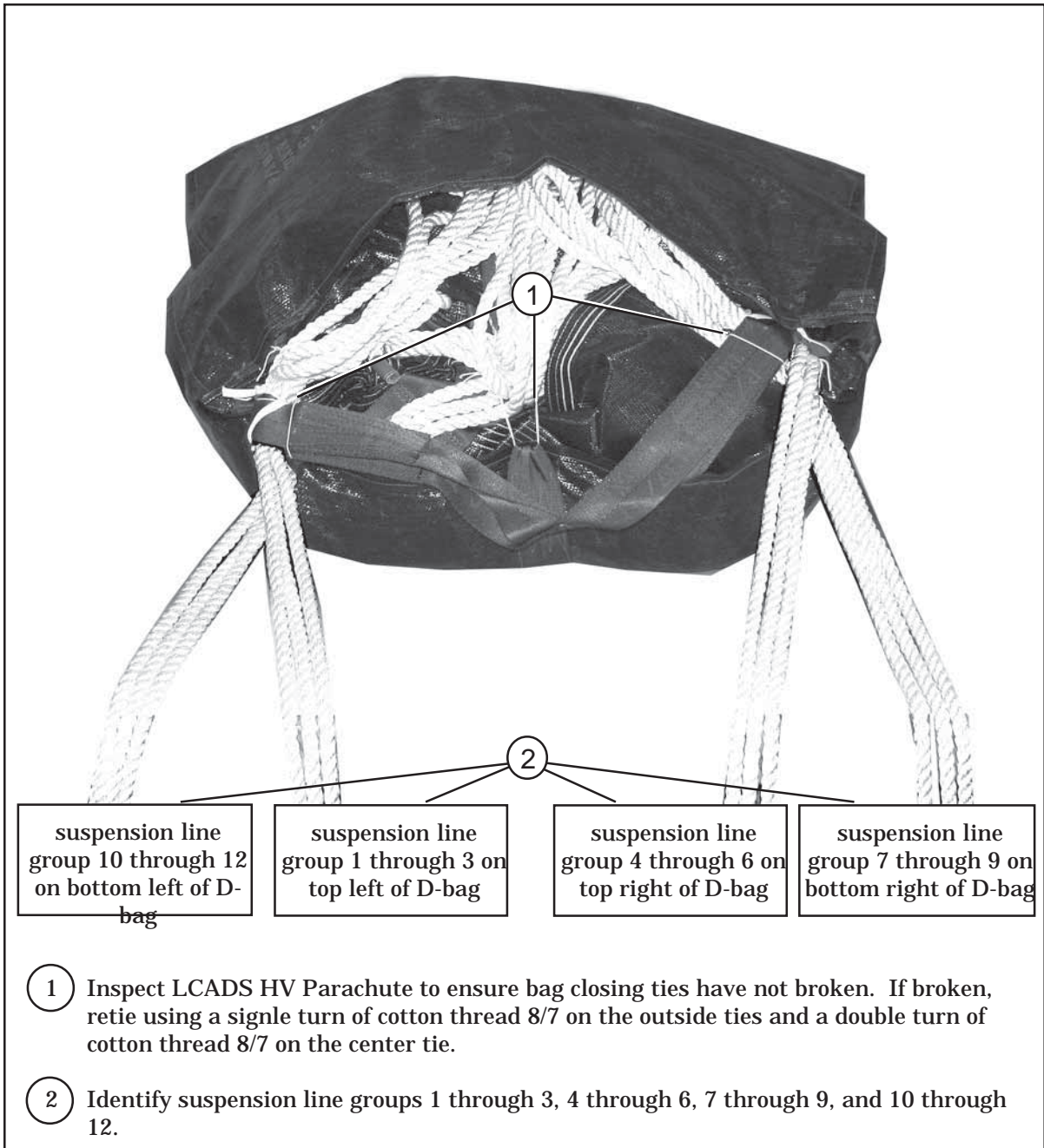
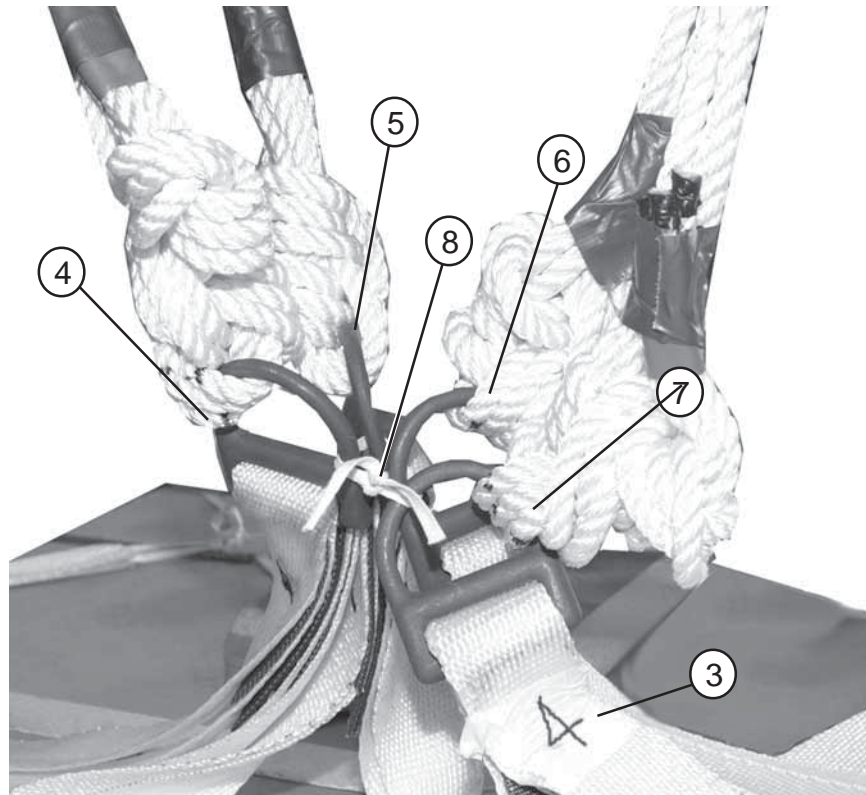


Figure 13-8. LCADS High-Velocity Parachute Installed



**CAUTION**

Failure to properly connect the suspension line groups could result in suspension lines or securing webs crossing.

- 3 Identify four D-rings on LCADS securing web as follows. Facing the container, D-ring 1 is near side of container, D-ring 2 is on left side of container, D-ring 3 is far side of container, and D-ring 4 is to the right side of container.
- 4 Route suspension line group 1 through 3, 30 inches through D-rings 1. Secure suspension line group with three alternating half-hitches and tape the running ends with 2-inch cloth-backed tape.
- 5 Route suspension line group 10 through 12 through D-ring 2 and secure same as step 4.
- 6 Route suspension line group 7 through 9 through D-ring 3 and secure same as step 4.
- 7 Route suspension line group 4 through 6 through D-ring 4 and secure same as step 4.
- 8 Secure the four D-rings together with 1/4-inch cotton webbing with surgeon's knot and locking knot.

**Figure 13-8. LCADS High-Velocity Parachute Installed (Continued)**

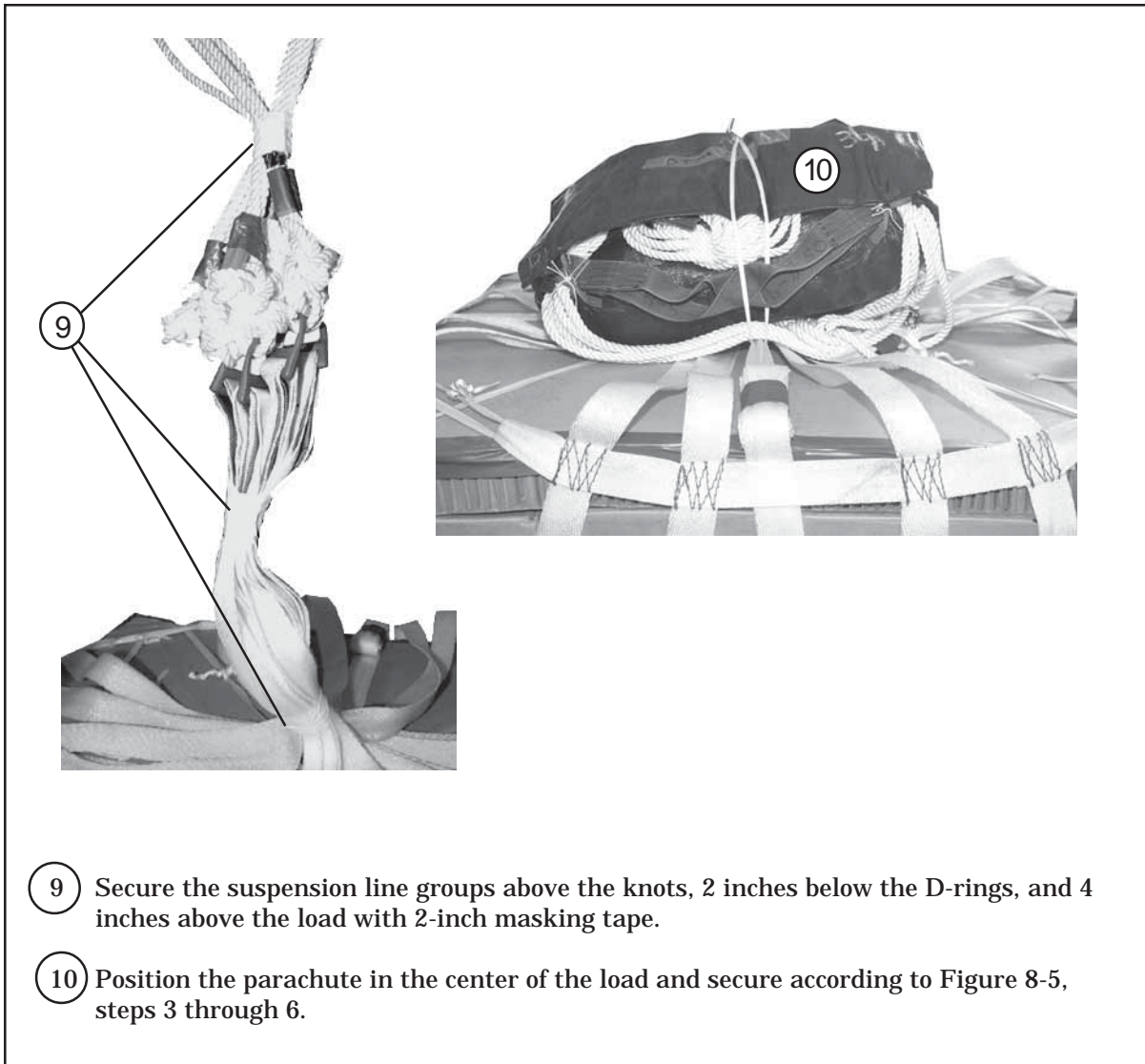



Figure 13-8. LCADS High-Velocity Parachute Installed (Continued)

**MARKING RIGGED LOAD**

13-17. Mark the rigged load according to Paragraph 1-5 and as shown in Figure 13-9. Compute the rigged load data.

**EQUIPMENT REQUIRED**

13-18. Use the equipment listed in Table 13-2 to rig the load shown in Figure 13-9.



**RIGGED LOAD DATA**

Weight: Minimum load allowed .....	501 pounds
Maximum load allowed .....	2,200 pounds
Height: .....	83 inches
Width: .....	48 inches
Length: .....	48 inches

**Figure 13-9. LCADS Rigged for High-Velocity Airdrop**

Table 13-2. Equipment Required for Rigging LCADS for High-Velocity Airdrop

National Stock Number	Item	Quantity
8040-00 -273-8713	Adhesive paste, 1-gallon	As required
No NSN	Bag, cover, 4 mil polyethylene (54- by 52- by 60-inches)	As required
No NSN	Shrink wrap	As required
No NSN	Sling assembly, LCADS	1
4030-00-678-8562	Clevis, suspension, 3/4-inch (medium)	1
4020-00-240-2146	Cord, nylon type III	As required
1670 -00 -753-3928	Pad, energy dissipating material, honeycomb 36- by 96- by 3-inches	3 sheets
No NSN	Parachute: LCADS, high-velocity	1
	or	1
1670 -00 -872-6109	Cargo, high -velocity, 26-foot	1 sheet
5530-00-128 -4981	Plywood, 3/4- by 48- by 96-inch	1 sheet
	or	
5530-00-914 -5118	Plywood, 1- by 48- by 96-inch	As required
7510-00-266-6710	Tape, masking, 2-inch	As required
8310-01-102-4478	Thread, cotton, ticket number 8/7	As required
	Webbing:	As required
8305-00-268-2411	Cotton, 1/4-inch, type I	As required
8305-00-082-5752	Nylon, tubular, 1/2-inch	As required

**This page intentionally left blank.**

## PART SIX

**RIGGING SPECIALIZED LOADS AND EQUIPMENT**

## Chapter 14

**Fabricating Air Force Airdrop Equipment****SECTION I - AIR FORCE UNILATERAL TRAINING****DESCRIPTION OF LOAD**

14-1. This chapter shows how to make a standard airdrop training bundle (SATB) for use in unilateral training by the Air Force. The SATB is used to simulate personnel, heavy equipment, and container airdrops from a C-130 aircraft. It consists of a sandbag filled with 13 1/2 pounds of sand or gravel and a locally made canvas bag. A 15-foot cargo extraction parachute deployment bag may be substituted for the canvas bag.

**PREPARING SANDBAG**

14-2. Fill a sandbag with 13 1/2 pounds of sand or gravel. Wrap the excess portion of the bag around the filled portion to make a compact unit. Secure the bag as shown in Figure 14-1.

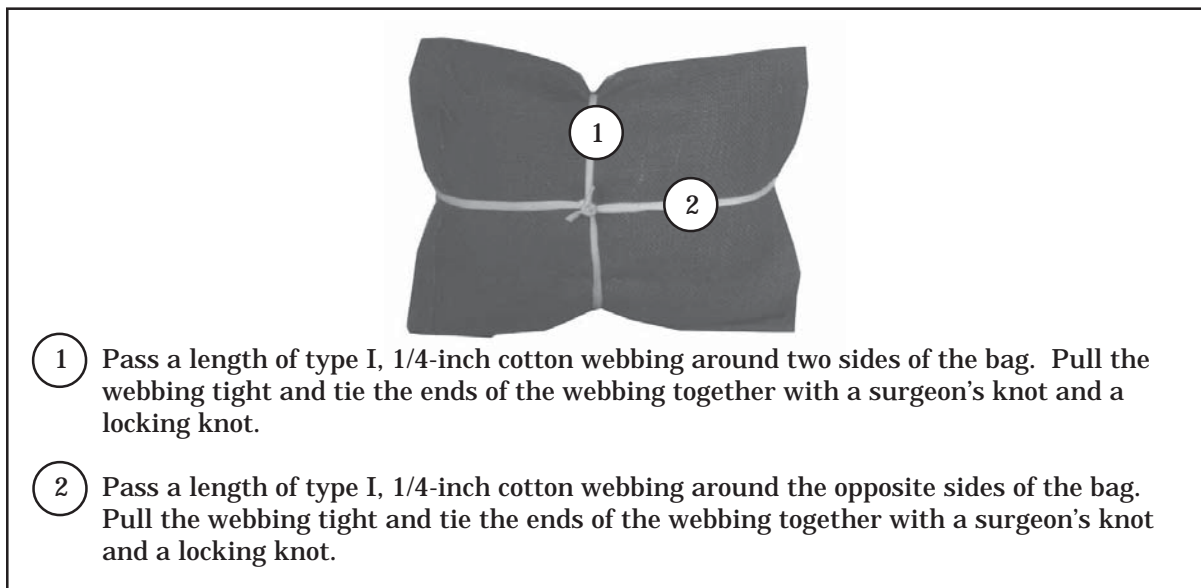


Figure 14-1. Sandbag Secured

## FABRICATING SATB

14-3. Construct a canvas bag as shown in Figure 14-2.

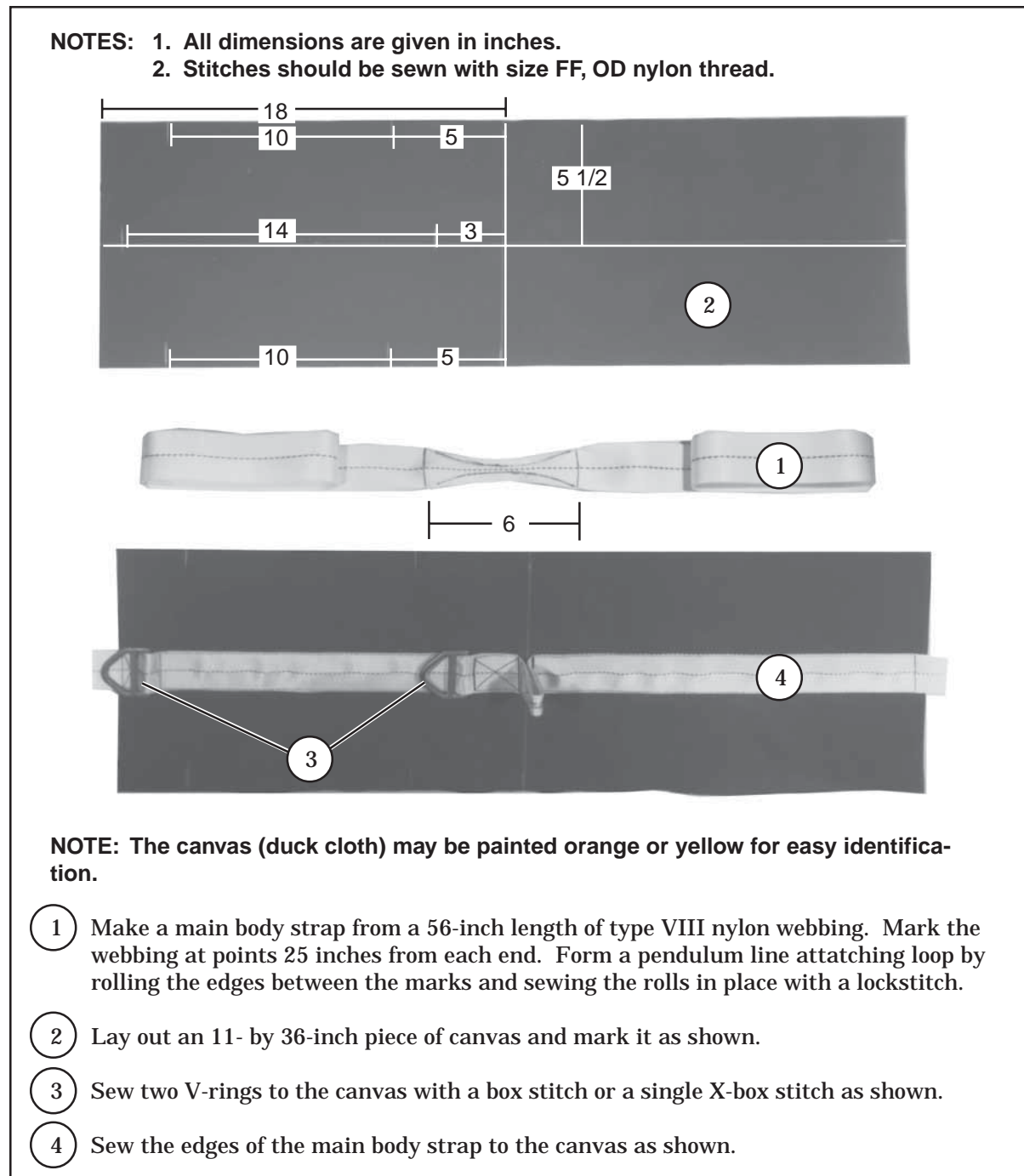


Figure 14-2. SATB Fabricated



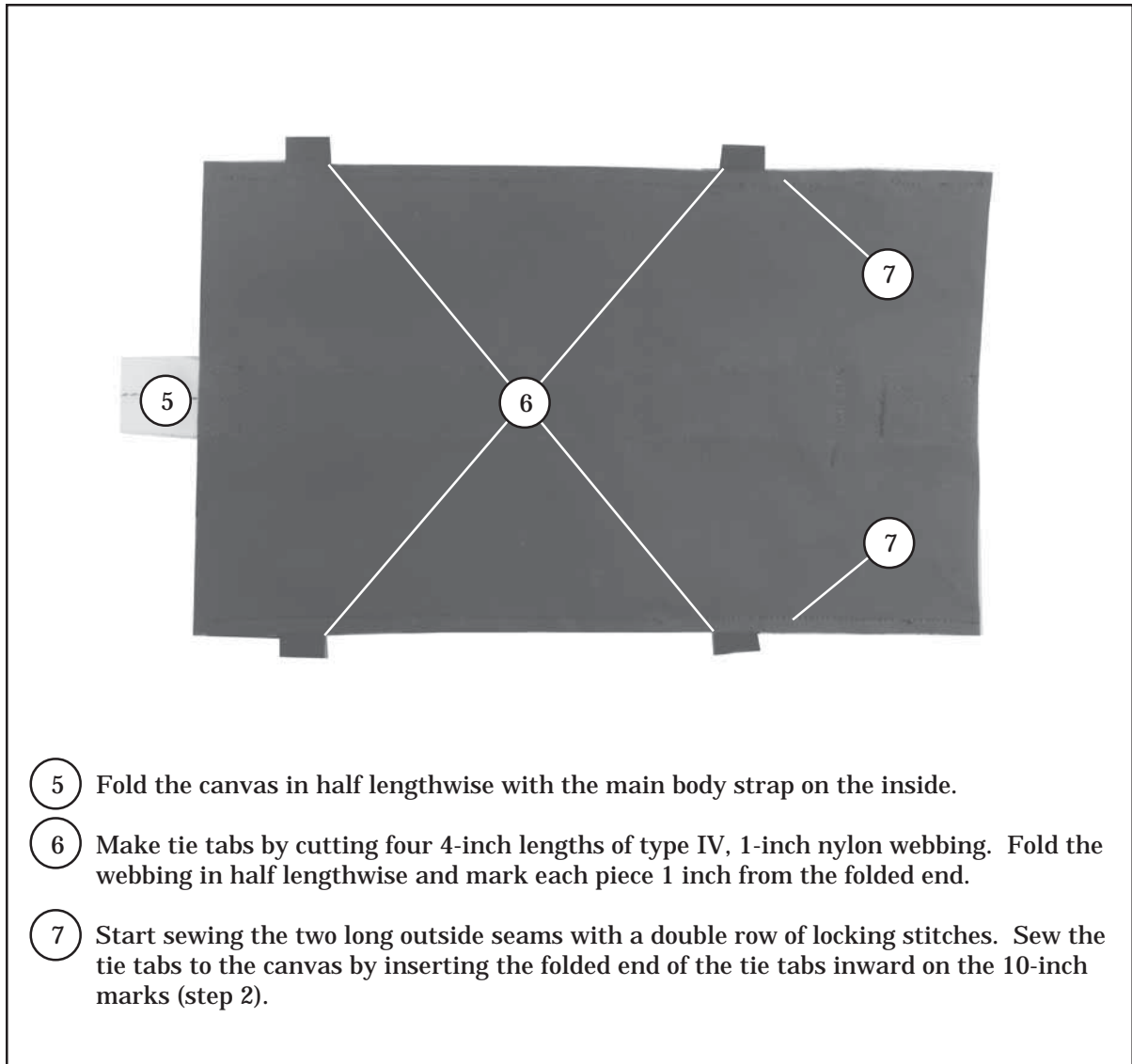


Figure 14-2. SATB Fabricated (Continued)

## ATTACHING PENDULUM LINE

14-4. Attach a 40-inch, type IV coreless nylon cord pendulum line to the pendulum line attaching loop of the SATB as shown in Figure 14-3.

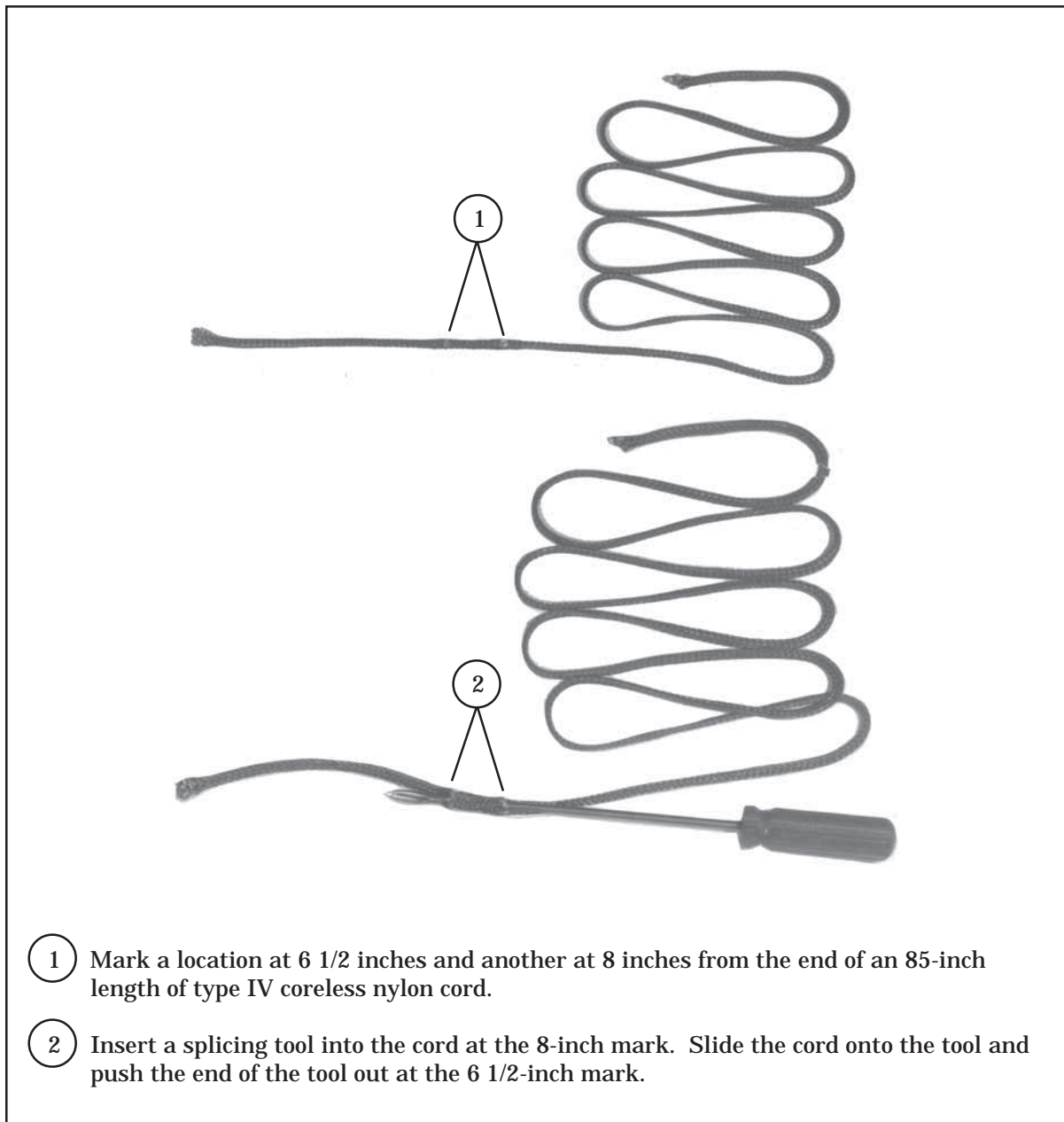


Figure 14-3. Pendulum Attached to SATB

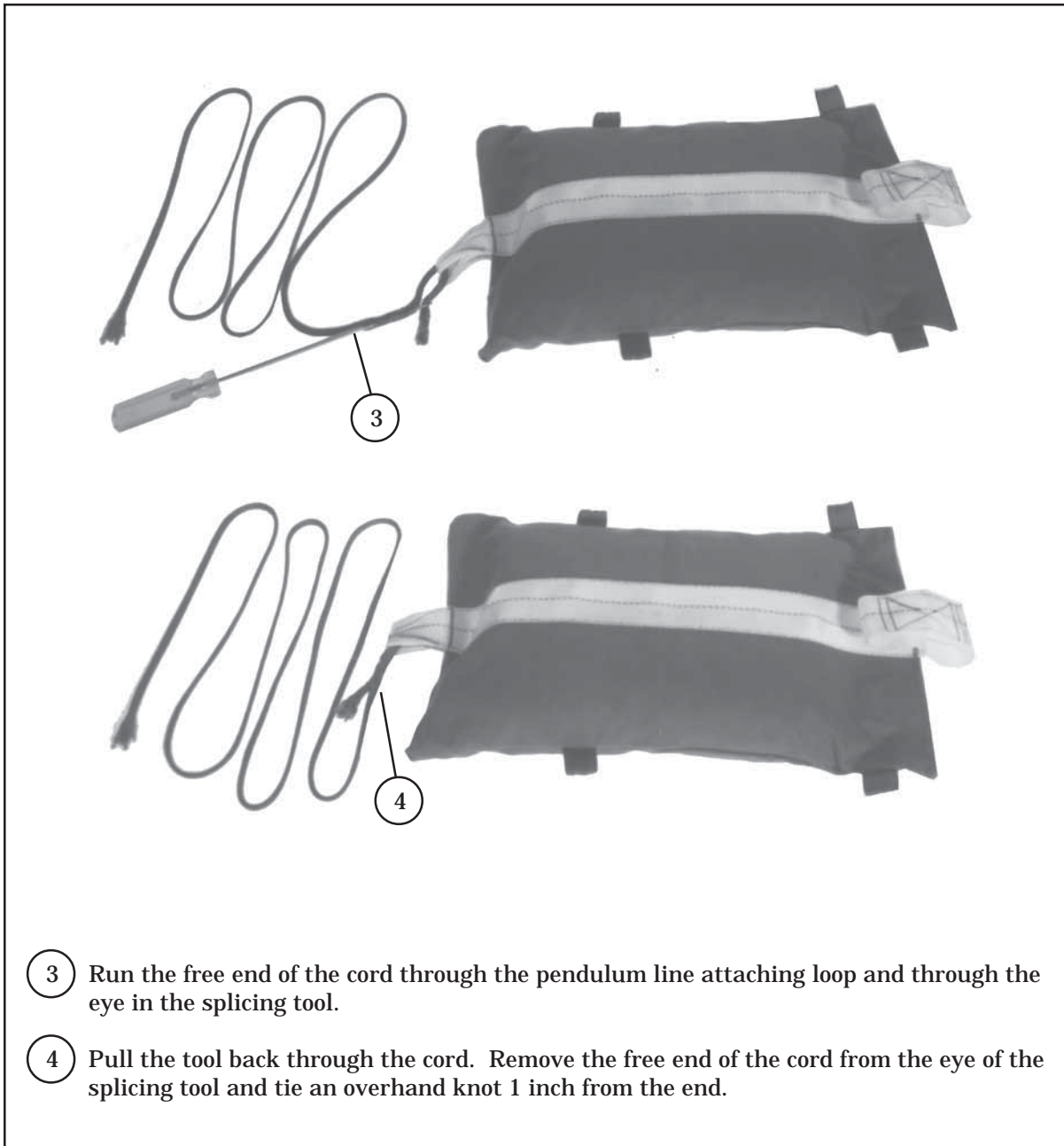


Figure 14-3. Pendulum Attached to SATB (Continued)

## PACKING AND INSTALLING PILOT PARACHUTE

14-5. Pack a 68-inch pilot parachute as outlined in TM 10-1670-281-23&P/ TO 13C5-32-2, but make the apex and bag-closing ties with single lengths of ticket number 8/4 cotton thread. Install the pilot parachute on the SATB as shown in Figure 14-4.

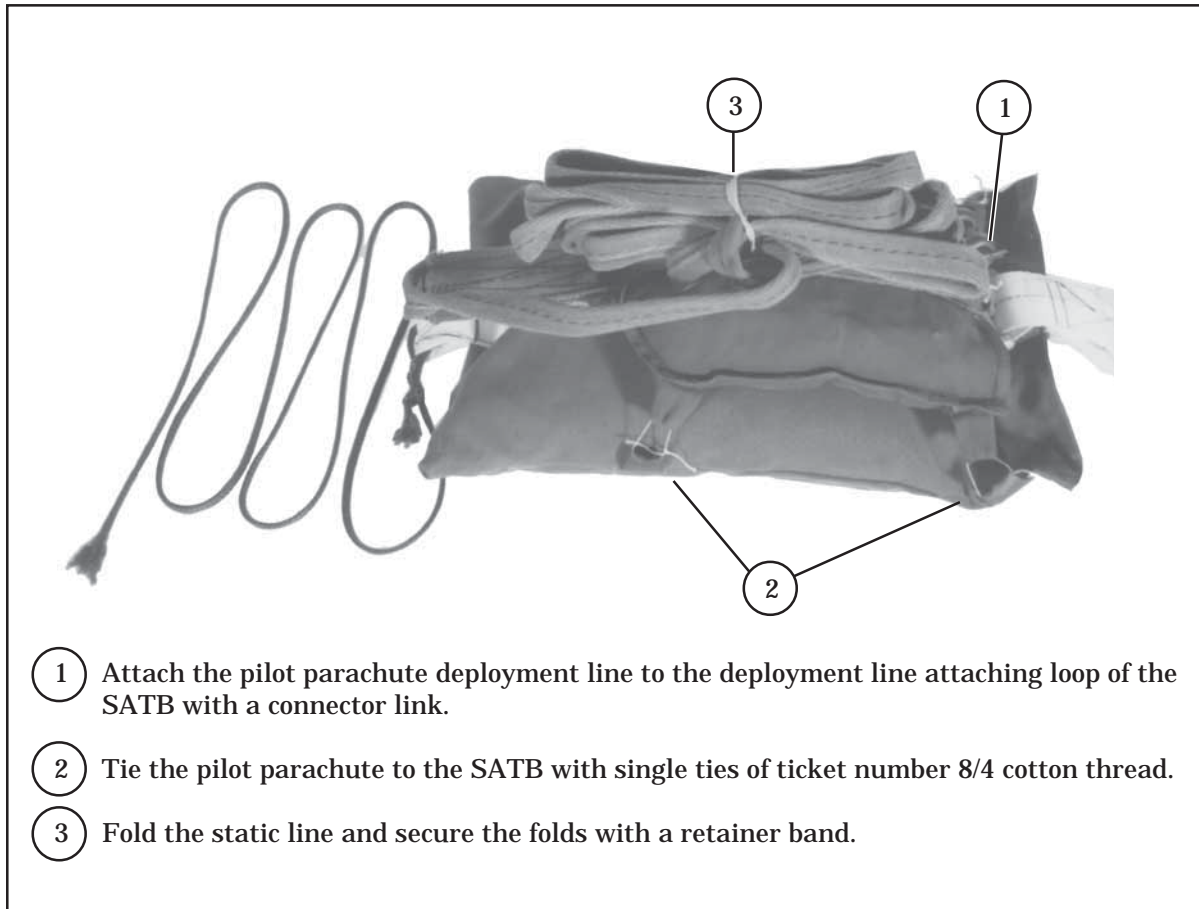


Figure 14-4. Pilot Parachute Installed on SATB

## ATTACHING MARKER LIGHT

14-6. For night operations tie a distress marker light or chemical light to a tie tape with a double length of type I, 1/4-inch cotton webbing.

## USING EXTRACTION PARACHUTE DEPLOYMENT BAG

14-7. If a 15-foot cargo extraction parachute deployment bag is substituted for the canvas bag used to enclose the sandbag, prepare the SATB as described below.

- a. Place the filled sandbag in the deployment bag and tie the deployment bag closed.
- b. Safety a 68-inch pilot parachute to the deployment bag as shown in Figure 14-5.

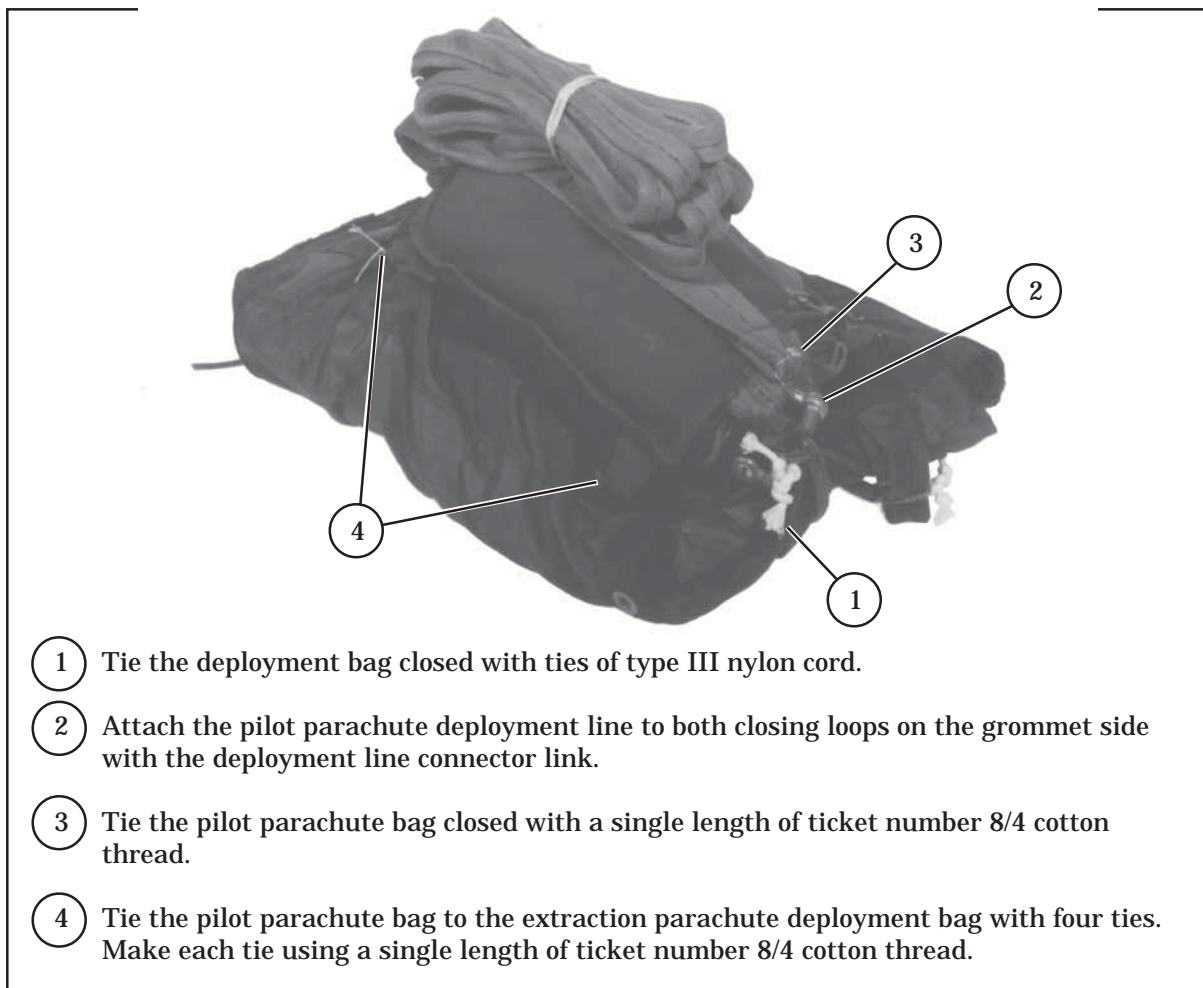


Figure 14-5. Pilot Parachute Tied to Deployment Bag

## EQUIPMENT REQUIRED

14-8. Use the equipment listed in Table 14-1 to rig the SATB.

Table 14-1. Equipment Required for Rigging an SATB

National Stock Number	Item	Quantity
1670-00-815-2727	Bag, deployment, 15-foot, cargo parachute	1
1670-00-568-0323	Band, rubber, retainer	1
8305-00-242-3593	Cloth, cotton duck, 60-inch	As required
	Cord, nylon:	
4020-00-262-2020	Braided, type IV	As required
4020-00-240-2146	Type III, 550-pound	As required
1670-00-217-2421	Link assembly, L-bar type	1
1670-00-216-7297	Parachute, pilot, 68-inch diameter	1
8105-00-285-4744	Sandbag	1
8310-00-102-4477	Thread, cotton, ticket number 8/4	As required
1670-00-360-0471	V-ring	2
	Webbing:	
8305-00-268-2411	Cotton, 1/4-inch, type I	As required
	Nylon:	
8305-00-268-2455	Tubular, 1-inch	As required
8305-00-263-3591	Type VIII, NT	As required

## SECTION II - FABRICATION OF C-130 CDS PULLEY STRAP

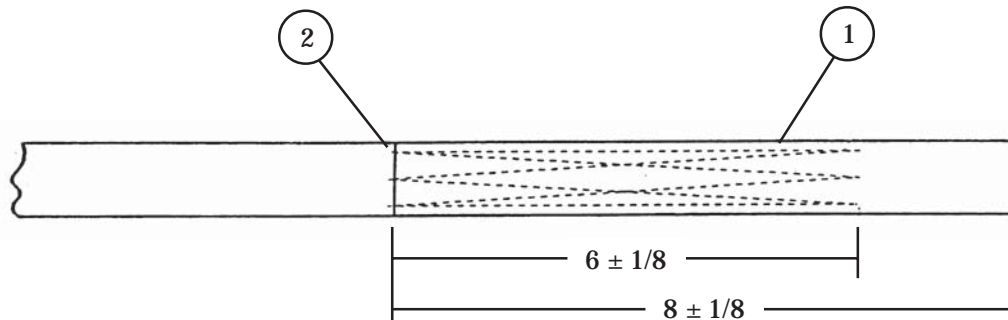
### DESCRIPTION OF C-130 CDS PULLEY STRAP

14-9. This section shows how to make a 1-inch tubular nylon webbing CDS pulley strap for use in C-130 aircraft. CDS pulley straps are used to suspend a pulley overhead in the aircraft to release the gate.

### PREPARING C-130 CDS PULLY STRAP

14-10. Prepare a 1-inch tubular nylon webbing CDS pully strap in lengths as specified in TO 1C-130A9 and as shown in Figure 14-6.

- NOTES:**
1. All stitching will be 1/8 inch from sides or spaced 1/8 inch apart unless otherwise specified.
  2. A 1/2-inch lock stitch must be made.
  3. All exposed ends of nylon webbing must be fused. Make sure no sharp edges are formed.
  4. All dimensions are in inches.



- 1 Use thread, type I or II, Class I, size 3, OD S-1, with five to seven stitches per inch.
- 2 Carry stitching over the end a minimum of one stitch.

Figure 14-6. C-130 CDS Pulley Strap Prepared

## SECTION III - CDS KIT

### DESCRIPTION AND USE OF CDS KIT

14-11. A CDS kit for C-130 aircraft is locally assembled and includes all the equipment required to drop CDS. The CDS kit contains additional equipment not normally carried on aircraft.

### EQUIPMENT REQUIRED

14-12. Use the equipment listed in Table 14-2 to assemble a CDS kit. The equipment list is for a single CDS kit single. Additional quantities may be required for multiple passes or a mass CDS drop.

**Table 14-2. Equipment Required for CDS Kit**

National Stock Number	Item	Quantity
5140-00-473-6256	Bag, tool, satchel	1
1670-00-406-2657	Ratchet, 10,000 pound	4
3020-00-517-1327	Pulley, assembly grooved	1
5305-00-167-0827	Bolt, Machine for pulley	1
5310-00-167-0821	Washer, flat	2
5310-00-950-0039	Nut, self-locking	1
1670-01-162-2372	Assembly, clevis, type V	1
1670-00-738-5879	120-inch strap, type X nylon webbing	1
8305-00-268-2455	** 114-inch strap, 1-inch tubular nylon webbing	2
8305-00-268-2455	** 95-inch strap, 1-inch tubular nylon webbing	1
8305-00-261-8584	** 41-inch strap, type X nylon webbing	1
8305-00-268-2455	** 24-inch strap, 1-inch tubular nylon webbing	1
1670-00-836-2231	Knife, release, cargo, guillotine	2
1560-00-650-4219	Yoke, assembly for knives	2
4030-00-618-6824	Terminal, wire rope	1
5310-00-877-5796	Nut, self-locking for knife terminal	2
5306-00-151-1423	Bolt, machine for knife terminal	2
8305-00-177-5069	* Type XXVI nylon webbing release gate	As required
8305-00-268-2453	1/2-inch tubular nylon, retriever winch cable loop guide	1

\* Normally provided by transported force.  
 \*\* Locally fabricated.



## Glossary

AFB	Air Force Base
AFMAN	Air Force manual
AFJ	Air Force Joint
AFTO	Air Force technical order
AMC	Air Mobility Command
AR	Army Regulation
CDS	container delivery system
CVRS	centerline vertical restraint system
DA	Department of the Army
DD Form	Department of Defense form
FM	field manual
GLLD	ground laser location designator
HQ	headquarters
LCADS	Low-Cost Aerial Delivery System
MCO	Marine Corps Order
MCRP	Marine Corps reference publication
NAVAIR	Naval Air Systems Command
NAVSEA	Naval Sea Command
No	number
NT	natural
OD	olive drab
OPNAVINST	Operational Naval Instruction
POP	performance oriented packaging
SATB	standard airdrop training bundle

TM technical manual  
TO technical order  
US United States  
USL universal static line

## Bibliography

- AFMAN 24-204(I)  
TM 38-250      Preparing Hazardous Materials for Military Air Shipments.  
December 2001
- AFTO Form 22      Technical Order Publication Improvement Report
- AR 59-4/OPNAVINST 4630.24C  
AFJ 13-210(I)/MCO 13480.1B      Joint Airdrop Inspection Records, Malfunction Investigations,  
and Activity Reporting. May 1998
- DA Form 2028      Recommended Changes to Publication and Blank Forms.
- DD Form 1748-1      Joint Airdrop Inspection Record (Container).
- FM 4-20.102      Airdrop of Supplies and Equipment: Rigging Airdrop  
NAVSEA SS400-AB-MMO-010      Platforms.22 August 2001  
TO 13C7-1-5
- FM 4-20.116      Airdrop of Supplies and Equipment: Reference Data for  
TO 13C7-1-13      Airdrop Platform Loads. 20 August 2001
- FM 4-20.153      Airdrop of Supplies and Equipment: Rigging Amunition.  
MCRP 4-11.3B      1 May 2004  
TO 13C7-18-41
- FM 10-500-9      Tactics, Techniques, and Procedures for Quartermaster  
Airdrop and Airdrop Support Units. 3 October 1995
- NAVAIR A1-H53BE-NFM-000      NATOPS Flight Manual, Navy Model CH-53E.  
15 August 2002
- NAVAIR A1-H53BE-CLG-000      Cargo Loading Manual, Navy Models CH-53D, CH53E and  
MH-53E Helicopters. 31 December 1998
- TM 10-1670-201-23      Organizational and DS Maintenance Manual for General  
TO 13C-1-41      Maintenance of Parachute and Other Airdrop Equipment.  
NAVAIR 13-1-17      30 October 1973
- TM 10-1670-275-23&P      Unit and Intermediate Direct Support (DS) Maintenance  
TO 13C5-25-2      Manual (Including Repair Parts and Special Tools List) for  
NAVAIR 13-1-26      Parachute Cargo Type: 12-Foot Diameter, High-Velocity  
Cargo Parachute. 17 March 1989
- TM 10-1670-276-23&P      Unit and Intermediate Direct Support (DS) Maintenance  
TO 13C5-29-2      Manual (Including Repair Parts and Special Tools List) for  
NAVAIR 13-1-29      Parachute Cargo Type: 26-Foot Diameter, High-Velocity  
Cargo Parachute. 28 September 1990


- TM 10-1670-278-23&P  
TO 13C5-26-2  
NAVAIR 13-1-27  
TM 01109C-23&P Unit and Intermediate Direct Support (DS) Maintenance Manual (Including Repair Parts and Special Tools List) for Parachute Cargo Type: 15-Foot Diameter, Cargo Extraction Parachute. 6 November 1989
- TM 10-1670-279-23&P  
TO 13C5-27-2  
NAVAIR 13-1-28 Unit and Intermediate Direct Support (DS) Maintenance Manual (Including Repair Parts and Special Tools List) for Parachute Cargo Type: 22-Foot Diameter, Cargo Extraction Parachute. 30 August 1989
- TM 10-1670-281-23&P  
TO 13C5-32-2  
NAVAIR 13-1-32 Unit and Intermediate Direct Support (DS) Maintenance Manual (Including Repair Parts and Special Tools List) for Parachute Cargo Type: 64-Foot Diameter, Model G-12D and Model G-12E. 1 October 1990
- TM 10-1670-282-23&P  
TO 13C5-30-2  
NAVAIR 13-1-33 Unit and Intermediate Direct Support (DS) Maintenance Manual (Including Repair Parts and Special Tools List) for Parachute Cargo Type: 34-Foot Diameter, Model G-14. 10 September 1991
- TM 10-1670-293-23&P  
TO 14D1-2-467-2 Unit and Intermediate Direct Support (DS) Maintenance Manual (Including Repair Parts and Special Tools List) for Parachute Personnel Type: 35-Foot Diameter, T-10C Troop Back Parachute Assembly and T-10D Troop Back Parachute Assembly. 30 August 2001
- TM 10-1670-298-20&P Unit and Intermediate Direct Support (DS) Maintenance Manual (Including Repair Parts and Special Tools List) for Container Delivery System. 15 September 1995
- TM 11-1520-237-23-7 Aviation Unit and Intermediate Maintenance Manual for UH-60A Utility Helicopter, UH-60L Utility Helicopter, UH-60Q Medical Evacuation Helicopter and HH-60L Medical Evacuation Helicopter, Volume No. 7. Helicopters. 1 April 2003
- TM 55-1520-240-23-10 Aviation Unit and Aviation Intermediate Maintenance Manual  
CH-47D. 19 September 2002
- TO 1C-130A-9 The Cargo Loading Manual. 2 April 2003

FM 4-20.103 (FM 10-500-3)  
MRCP 4-11.3C  
TO 13C7-1-11  
2 September 2005

By Order of the Secretary of the Army and the Air Force and by direction of the Commandant of the Marine Corps:

**PETER SCHOOMAKER**  
*General, United States Army*  
*Chief of Staff*

Official:

  
**SANDRA R. RILEY**  
*Administrative Assistant to the*  
*Secretary of the Army*  
0523406

**J. N. MATTIS**  
*Commanding General, U.S. Marine Corps*  
*Deputy Commandant for Combat Development*  
*Marine Corps Combat Development Command*

**GREGORY S. MARTIN**  
General, USAF  
Commander, AFMC

**JOHN P. JUMPER**  
General, USAF  
Chief of Staff

**DISTRIBUTION:**

Active Army, Army National Guard, and U.S. Army Reserve: To be distributed in accordance with the initial distribution number 110895, requirements for FM 4-20.103.

**This page intentionally left blank.**



